

Owners Manual

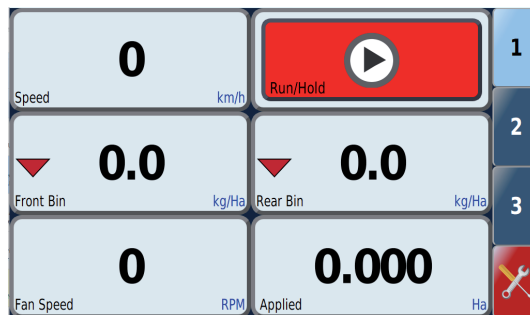

Renovator AST6000 ORIGINAL INSTRUCTIONS

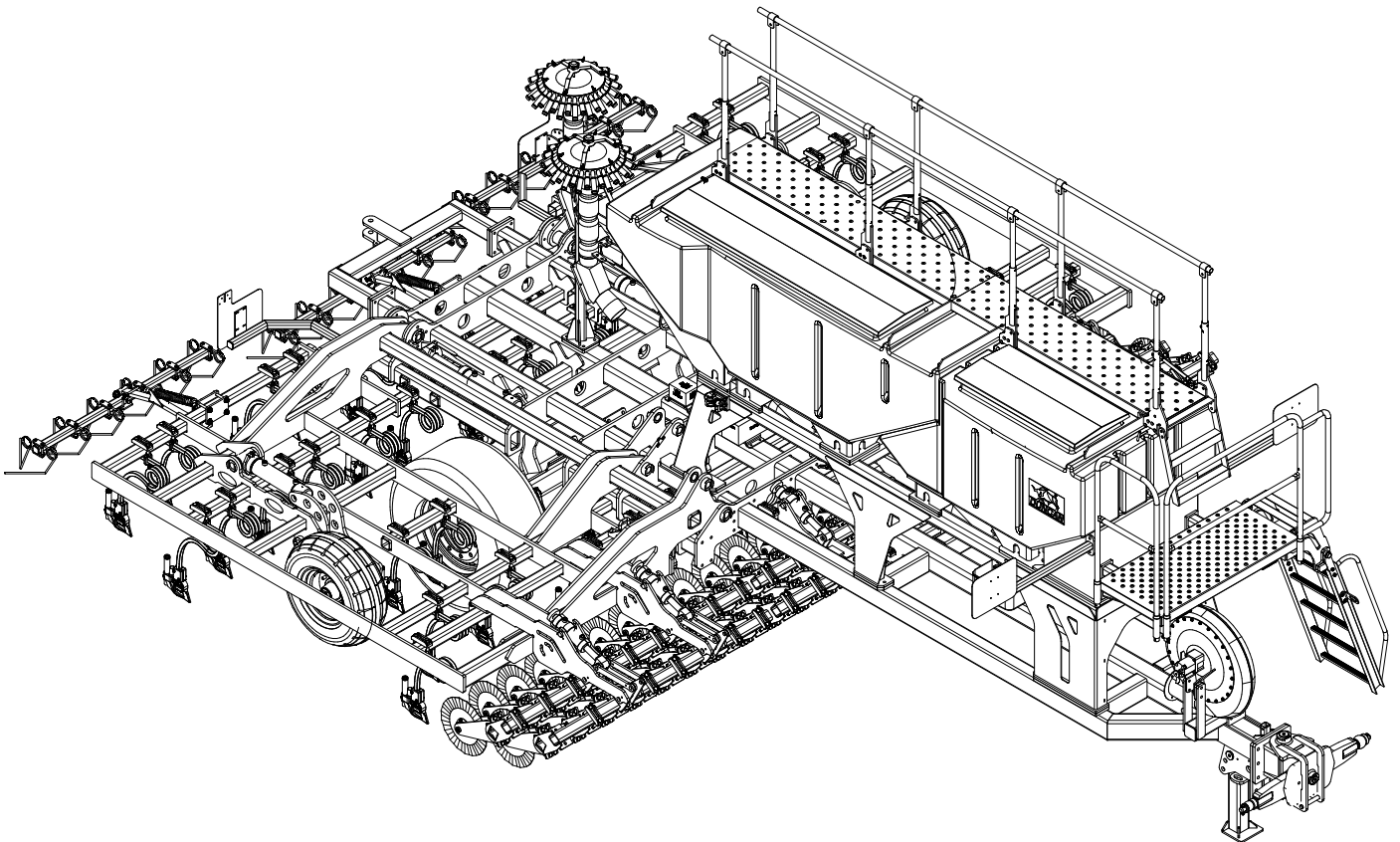

Timaru Branch:
100 Hilton Highway, Washdyke,
Timaru, New Zealand
Tel: +64 3 688 2029
Email: timadmin@giltrapag.co.nz
Web: www.giltrapag.co.nz

Australian Branch:
105-117 Boundary Road,
Laverton North, Melbourne,
VIC 3026, Australia
Tel: +61 3 9369 6548
Email: admin@giltrapag.com.au
Web: www.giltrapag.com.au

**Pt. No. 67496
Rev 1025**

Renovator AST6000 Contents

	Page
Introduction	2
Acquisition & Warranty	2
Disclaimer	2
Description of Machine Working Principle.....	3
Specification Dimensions & Capacities	4, 5
SAFETY - General Safety Symbols on Machine	6
Operator Safety.....	7
Be Prepared for Emergencies.....	7
Appropriate Dress	8
Transport This Machine Safely	8
Handle Agricultural Chemicals Safely.....	9
Avoid High Pressure Fluids.....	9
Safe Work Practices	9
Practice Safe Maintenance	10
SAFETY - Machine Specific Hazard Points	11
Safety Decals & Safety Guards.....	13
Transport	15
Setup, Calibration & Operating Procedure General Operation	16
Read Before Operation	20
SmartAG Overview	22
Sowing Chart and Pre-Calibration Setup	26
Calibration	28
Airflow & Fan Speed	32
Blank Page for your Calibration Notes	33
Maintenance & Care General	34
Lubrication Instructions	35
Maintenance Schedule	36
Storage	37
Hydraulics Hose Connection Colours.....	39

Introduction

Acquisition & Warranty

On delivery of your new Duncan Renovator AST6000 please check that the machine is not damaged. In cases of shipping damage, please ask your dealer to arrange for the appropriate claim to be lodged immediately. Assemble any parts supplied loose and inspect your machine with the aid of this manual to familiarise yourself with its features. If you have any queries ask your dealer straight away. The machine is covered by our 12 month warranty on faulty parts, subject to normal use.

Record below the serial number of your machine and keep it in a secure place to help trace the machine and assist us when you order parts.

The Owner's Manual

Model:

Serial No:

Owner:

.....

.....

Delivery Date:

Dealer:

.....

.....

Your new Duncan Renovator AST6000 will give long and efficient service if given normal care and operated properly.

This owner's manual is provided so that you can become thoroughly familiar with the design of the machine and to furnish information on correct operation, adjustment and maintenance. **Only persons well acquainted with these guidelines should be allowed to use the equipment.**

A separate illustrated parts section has been provided so that if any parts are required your dealer will be able to supply them by reference to part numbers.

The manual is considered as part of your machine and must remain with the machine when it is sold.

Right and left hand references in this manual are determined by standing behind the machine and facing in the direction of travel.



Disclaimer

Every effort has been made to ensure that the information in this manual was accurate and up to date at the time of going to press. Giltrap AG reserves the right to make subsequent changes to the machine, where necessary, without notification.

The Company will not be responsible for any damage or consequential loss arising out of misinterpretation or failure to follow recommended procedures. Nor will it be liable for any damage caused by or arising out of modification or misuse of its product.

The owner has a responsibility to protect himself and others by observing all safety information and by ensuring all operators are well acquainted with the safety information, trained in the correct use of the machine and applying safe work practices.



Description of Machine

The Duncan 'Renovator AST6000' is a Coil Tine T-boot drill and is fitted with disc openers.

The large moulded hoppers are mounted on a robust centre frame with easy calibration access.

Sowing depth is hydraulically controlled. The quality European air metering units handle all seeds from turnip and rape through to peas and maize and permits easy calibration. The seeders are driven via a GPS speed proportional electric drive system. Seeding ceases automatically when the machine is raised into the transport position.

The wings may be hydraulically folded up for legal transport width.

Working Principle

The air flow, metering units and electric drive system are easily set to give the desired sowing and/or fertilizer rate. The front disc precuts the ground surface followed by the coil tine and T-boot which creates the seed bed. Air delivers seed down the flexible tubes between the seeder and tee-boot units and drops into the prepared seed bed.

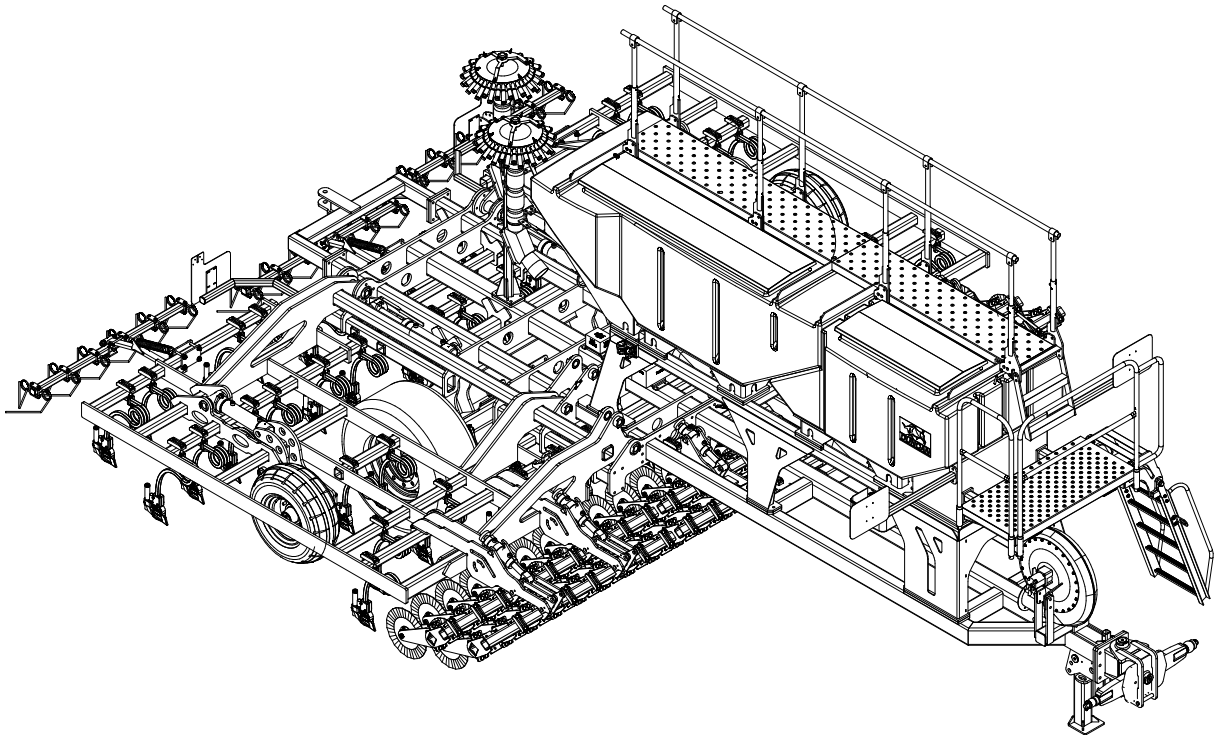

'Renovator AST6000' Dimensions & Capacities

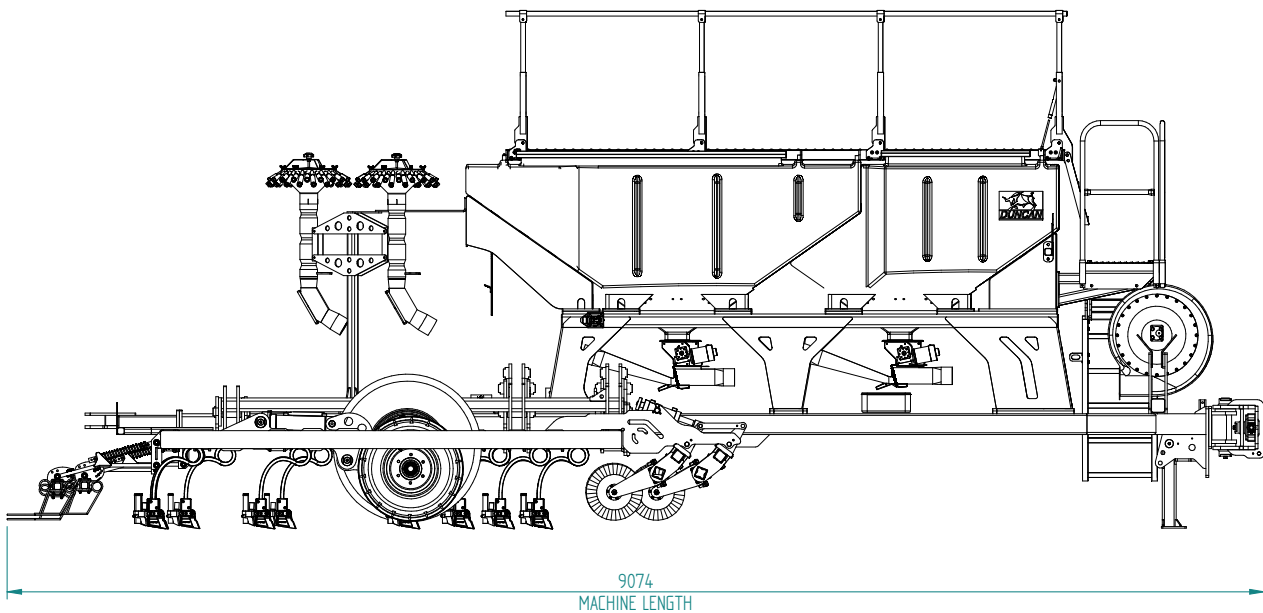

Dimensions & Capacities	48 Run
Description	6.0m 5 inch
Transport Width (mm)	3086
Transport Height (mm)	3474
Machine Length (mm)	9074
Working Width (mm)	6026
Working Height Safety Rails down (mm)	2946
Loading Height (mm)	2700
*Working Height Safety Rails up (mm)	3742
Weight - incl disc openers - unladen (kg)	10,100
Row Spacing (mm)	125
Sowing Width -effective (mm)	6000
Box Capacity per bin	Front: 1500 litres Rear: 2000 Litres
Main Tyre Size & Inflation Pressure	400/60-22.5 Alliance 328 Flotmaster (4 bar/58psi)
Wing Tyre Size	10/75-15.3 18 ply Mitas IM-04

'Renovator AST6000' Dimensions & Capacities

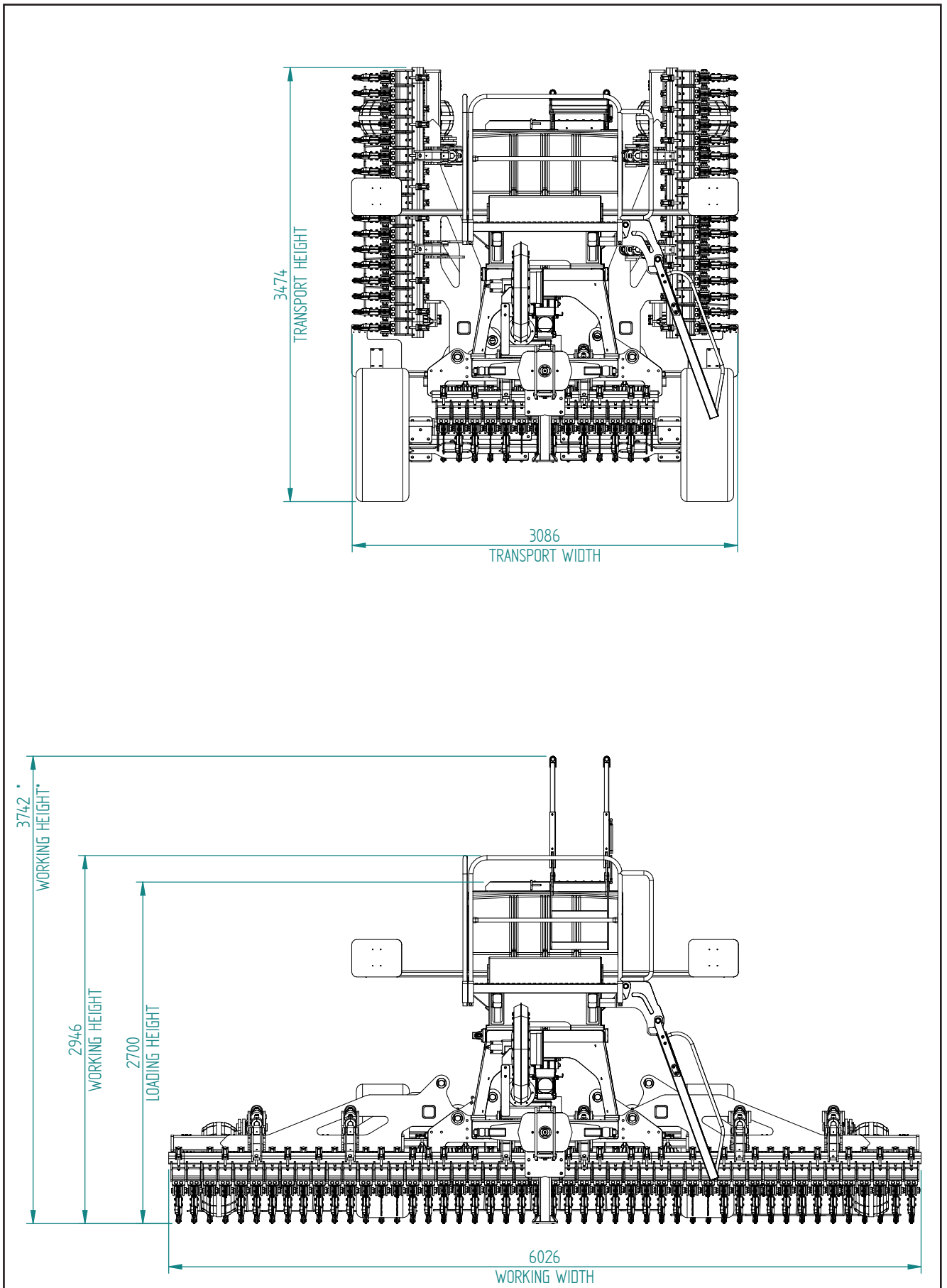

'Renovator AST6000' Safety



ATTENTION

On the machine important safety information is indicated by these symbols. These highlight general safety aspects in regard to the machine rather than specific hazards.



Do not ride or allow passengers on the machine.

Under no circumstances are passengers to be permitted on the machine while it is in operation or being transported. Any footboards and/or footsteps are provided solely for the purpose of preparing the machine for use.



Keep clothing and body extremities well clear of pinch points while the machine is operating (seeding or calibrating). Keep well clear of moving parts at all times.

These signs typically occur wherever trapping points exist. These include drive chains, sprockets, shafts, wheels, discs, pivot points, etc. Guards are provided with the machine for safety reasons (where practical without compromising machine performance). Ensure these are always fitted during operation.



Always exercise extreme caution in the vicinity of sharp edges and points.

Where possible guards are provided with the machine for safety reasons (where practical without compromising machine performance). Ensure these are always fitted during operation.



Footboards, footsteps, drawbars and other machine surfaces may be slippery when wet.

Apply extra caution in wet conditions and in the early morning when surfaces are wet.

KEEP CLEAR

Keep Clear. (It is dangerous to be in this area when the machine is operating.)

'Renovator AST6000' Safety

SAFETY - General

N.B. Throughout this manual important safety information is indicated by these symbols in the margin:



A prohibition should be observed under all circumstances.



A warning indicates a hazard that could cause death or injury if the warning is ignored.



A caution indicates a hazard that may cause damage to property if the caution is ignored.

This section of the manual offers general guidelines for the safe operation of machinery. It does not replace local safety regulations. These guidelines were current at the time of publication, but may be superseded by later regulations.

Giltrap AG has made every effort to highlight all risks to personnel or property. Owners and operators have a responsibility to exercise care and safe work practices at all times in the vicinity of the machine.

Owners are advised to keep up to date on safety issues and to communicate these to all users of the machine.

Contact the Occupational Safety and Health Service (OSH) for further information about general safety aspects. If you have safety concerns specifically related to this machine, contact your dealer immediately.

Operator Safety

Read this manual carefully before operating new equipment. Learn how to use this machine safely. Be thoroughly familiar with the controls and the proper use of the equipment before using it.

Take careful note of all safety instructions both in this manual and on the machine itself. Failure to comply with instructions could result in personal injury and/or damage to the machine.

Replace missing or damaged safety signs on the machine and ensure that these remain clearly visible.

It is the owner's responsibility to ensure that anyone who operates, adjusts, lubricates, maintains, cleans or uses the machine in any way has had suitable instruction and is familiar with the information in this manual (particularly with regard to safety aspects).

Operators and other users of the machine should be aware of potential hazards and operating limitations.

Be Prepared for Emergencies

Keep a first aid kit and fire extinguisher handy.

Keep emergency numbers for doctors, ambulance, hospital and fire department near your telephone.



'Renovator AST6000' Safety

SAFETY - General (Continued)



WARNING

Appropriate Dress

Wear close fitting clothing and avoid rings or other forms of jewellery which could become caught in the machinery.

People with long hair must have it securely fixed and confined close to the head.

Refer to local safety standards for protective clothing and recommended safety equipment.

Adequate protection, such as a face mask, should be worn if operating this machine in dry and dusty conditions.



WARNING

Transport This Machine Safely

Ensure that all linkage pins and security clips are fitted correctly. With trailing machines tow with the drawbar only, as this is the only safe towing point on the machine.

Always check that bystanders (especially children) are well clear (front and rear) before starting and moving the tractor and the machine.

Plan safe routes of travel, and be aware of power lines and other roadside hazards. Take particular care when towing implements on hillsides.

Do not ride or allow passengers on the machine.

This machine is not designed to carry passengers, and no riders are permitted.



NO RIDE

Road transport

On public roads,

- A speed of 40km/h must not be exceeded.
- Do not operate during the hours of darkness unless standard lights are fitted and clearly visible. (This also applies when visibility is limited, e.g., in foggy conditions.)

See the guidelines in the *Vehicle Dimensions and Mass Rule*, issued by the Land & Transport Safety Authority.

Avoid tip-overs

Avoid holes, ditches and obstructions which may cause the machine to tip over, especially on hillsides. Never drive near the edge of a gully or steep embankment - it might cave in. Slow down for hillsides, rough ground and sharp turns.



'Renovator AST6000' Safety

SAFETY - General (Continued)

Handle Agricultural Chemicals Safely

All farm chemicals should be stored, used, handled and disposed of safely and in accordance with the supplier's/manufacturer's recommendations.



Read the product label before using, noting any warnings or special cautions, including any protective clothing or equipment that may be required, ie. respirator.

Do not eat or smoke while handling sprays, fertilisers, coated seeds, etc. Afterwards, always wash your hands and face before you eat, drink, smoke, or use the toilet.



Store sprays, fertilisers, coated seeds, etc. out of reach of children and pets, and away from food and animal feeds.

Any symptoms of illness during or after using chemicals should be treated according to the supplier's/manufacturer's recommendations. If severe, **call a physician or get the patient to hospital immediately.** Keep the container and/or label for reference.

Avoid High Pressure Fluids

Avoid any contact with fluids leaking under pressure, because the fluids can penetrate the skin surface.



Any fluid which penetrates the skin, will need to be **removed immediately by a medical expert.** Seek specialist advice on this type of injury.

Relieve the pressure before disconnecting any hydraulic or other lines. Make all repairs and tighten all fittings before re-connection to pressurised fluid.

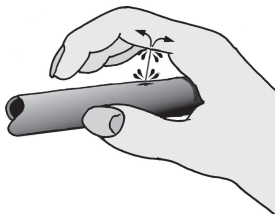

Keep your hands and body away from any pinholes or high pressure jets. Search for leaks with a piece of cardboard instead of using your hand directly.

Safe Work Practices

All farm machinery is potentially dangerous and should be treated with caution and respect.

Before starting the machine, ensure that all controls are placed in neutral and that bystanders are well clear. Check that the guards have been securely fitted and that any adjustments have been made correctly.



Where possible, disconnect or isolate the drive mechanism to the implement. Lower the machine onto the ground when not in use.

Do not operate this equipment when severe weather conditions appear imminent.

'Renovator AST6000' Safety

SAFETY - General (Continued)



Practice Safe Maintenance

Keep the machine in safe working condition. Routine maintenance and regular servicing will help reduce risks and prolong the life of the machine.

General Maintenance

Accidents occur most frequently during servicing and repair. The following general rules must be followed when maintaining or working with machinery:

- All operating and maintenance manuals must be read before and referred to while using or servicing any piece of equipment.
- Turn off all machinery power sources and isolate the machine before making adjustments, doing lubrication, repairs or any other maintenance on the machine.
- Ensure that the machine hydraulics are disconnected from the power source.
- Wear gloves when handling components with cutting edges, such as any ground cutting components.
- Beware of hazards created by springs under tension or compression when dismantling or maintaining the machine.
- It is recommended that you clean the machine with a water blaster or similar apparatus before commencing maintenance.

Make Sure the Machine is Well Supported

When machinery is fitted with hydraulics, do not rely on the hydraulics to support the machine. During maintenance or while making adjustments under the machine, always lock the hydraulics and support the machine securely. Place blocks or other stable supports under elevated parts before working on these.

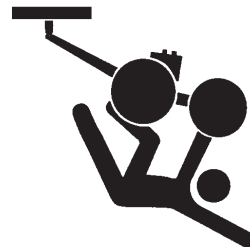

Electrical Maintenance

Disconnect the electrical supply from the tractor before doing any electrical maintenance.



Welding

With electronic equipment in modern tractors it is advisable to disconnect the machine from the tractor, or at least disconnect the alternator and battery before attempting any welding.



Use Only Genuine Spare Parts

Unauthorised modifications or non-genuine spare parts may be hazardous and impair the safe operation and working life of the machine.

Excess lubricants must be disposed of safely so as not to become a hazard.

'Renovator AST6000' Safety

SAFETY - Machine Specific

This section of the manual gives specific guidelines for the safe operation of the Renovator AST6000.

These guidelines were current at the time of publication, but may be superseded by later circumstances. They do not necessarily cover every possible hazard and must be read in conjunction with the **SAFETY - General** section (Page 7 to 10).

Hazard Points on the Renovator AST6000

The lists below are not all-inclusive and serve only to highlight the more obvious areas of risk.



The decals attached to the machine are a general reminder that there are hazardous areas on the machine, rather than specifically highlighting all possible hazards.

For decal locations on machine, refer Page 13.



No Ride

Passengers are not permitted anywhere on the machine.



Pinch Points/Moving Parts

Hazardous areas include:

- Front Tractor Linkage
- Fan Unit
- Front Disc openers
- Wings
- Electric Drive units
- Roller
- Wheel legs and main frame assemblies
- Finger tine assemblies (where fitted).



**Slippery
When
Wet**

Slippery When Wet

Hazardous areas include:

- Footboards and footstep.
- All smooth surfaces on the frame structure.

KEEP CLEAR

Keep Clear

Hazardous areas include:

- Between the tractor and Renovator AST6000.
- Immediately adjacent to the Renovator AST6000 side.

'Renovator AST6000' Seed Drill Safety

SAFETY - Machine Specific (Continued)



Hazard Points on the Renovator AST6000 (Continued)

For guard locations on machine, refer Page 13.



Transport

The two wheels located at the rear of the machine are for the purpose of controlling sowing depth. These are also used to support the machine weight.

Important - Refer to safety cautions in the **Transport** section, page 15 of the manual. Ensure that all linkage pins and security clips are fitted correctly.

Maintenance

Refer Page 34 for reference to the **Maintenance and Care** section of the manual.

Lubrication

Refer Page 34 for reference to the **Maintenance and Care** section of the manual.

'Renovator AST6000' Seed Drill Safety

SAFETY - Machine Specific (Continued)

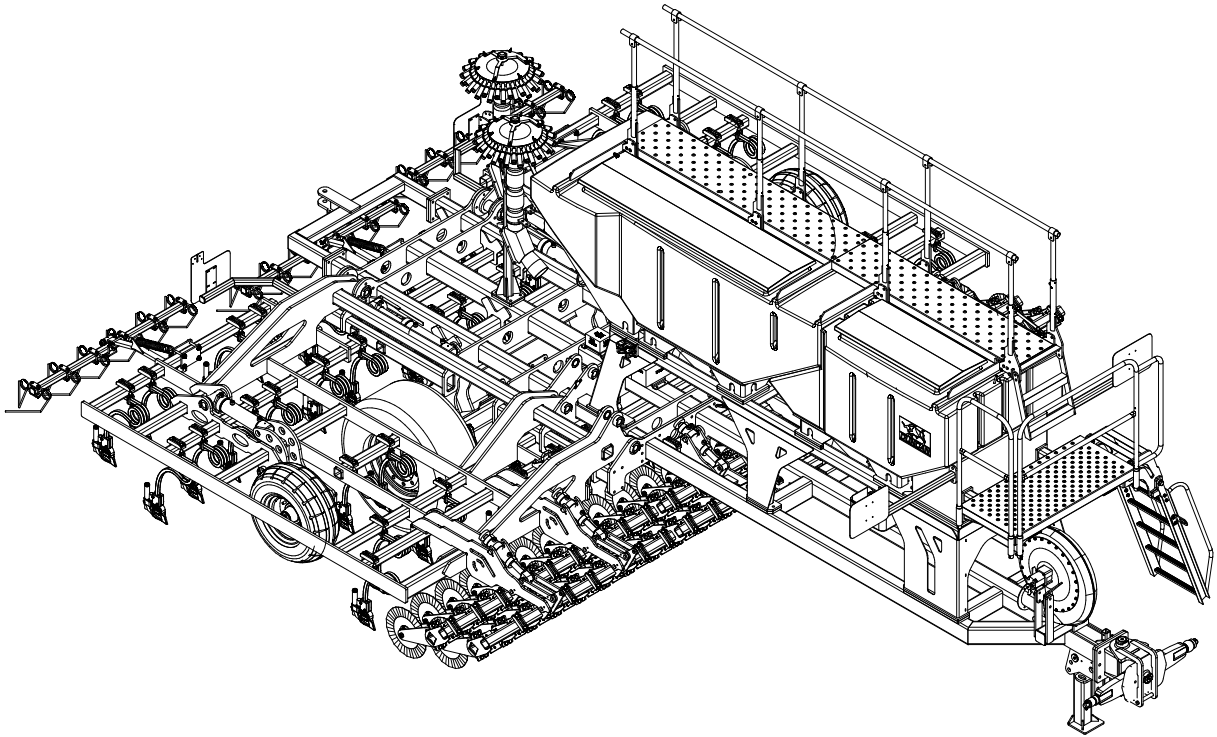

Item	Decal/Guard	Pt. No.
1	'No Ride'	43900
2	'Pinch Point/Moving Parts'	43901
3	'Slippery When Wet'	43902
4	'Keep Clear'	43904
5	'40 km/hr'	43912
6	'Hose Connection Colours'	72818

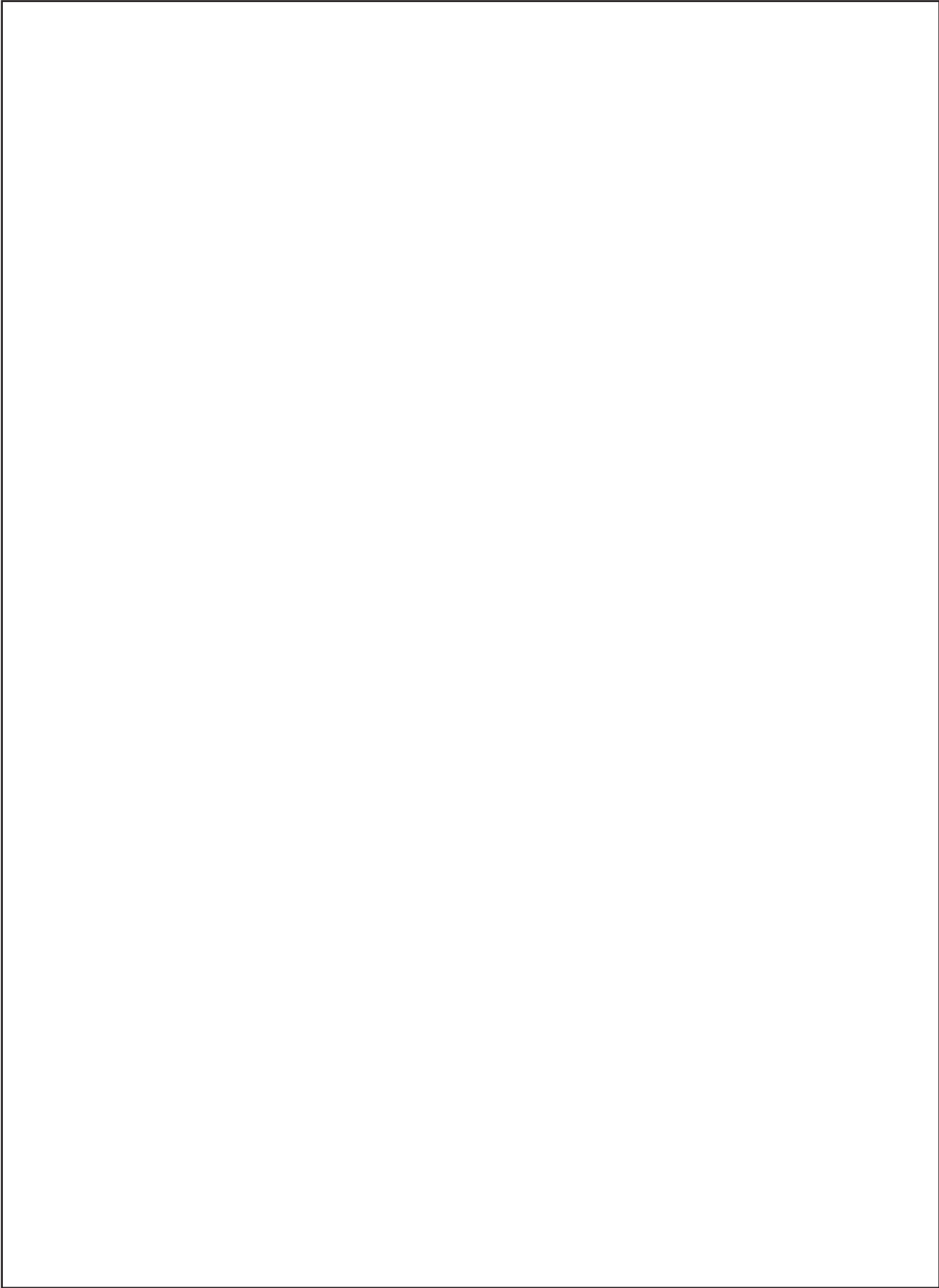

'Renovator AST6000' Transport

Transport

1 Maximum towing speed 40 km/hr.



For countries other than New Zealand other speed restrictions may apply, please refer to your local transport authority.

Ensure towing vehicle requirements are adequate for the towed vehicle e.g. mass, brakes. Refer to recommendations published by the local Land Transport Authority or equivalent.

Braking when towing can cause the load to jackknife. Use extra care when towing in adverse conditions such as mud, inclines and sharp bends.



Lower towing speeds are recommended on farm roads/tracks and where one wheel is on or over a road verge.

2 Attach safety chains to tractor.

Safety chains must be crossed over underneath the coupling and attached to the towing vehicle. The attachment points must be as close as practical to the towing coupling and one each side. The towbar on the towing vehicle must be rated for the towed mass. **Do not remove or replace the safety chains provided with any other type than those supplied.**

Note: The safety chains are provided with sufficient length to cater for all towing vehicles. Safety chains must be shortened by cutting off excess length so that if the coupling fails the drawbar will not hit the ground.

'Renovator AST6000' General Operation

Operation

General Operation Guidelines

- 1 Hydraulic Fan -connect the hoses in the following order:



First - connect Zero pressure Case Drain 3/8" hose (1/2" BSP Female QR) to hydraulic reservoir * Hose marked with short RED wrap.

Second -connect Motor Return 3/4" hose (3/4" BSP Female QR) to tractor high flow low pressure return port. Hose marked with medium length RED wrap.

Finally - connect High Pressure Motor feed 1/2" hose (1/2" BSP Male QR) to tractor remote. Hose marked with long RED wrap.

Disconnect in the reverse order to prevent motor seal damage.



***The tractor hydraulic reservoir or free drain connection must have zero backpressure.**

- 2 Use a sufficiently powerful tractor which is heavy enough to tow the drill safely.
- 3 Operate the drill at a speed of 6-12 km/hr (4-8 mph).
In stony and uneven ground conditions a lower speed is more appropriate
- 4 Check that the drill is level during calibration and while seeding.
- 5 Check tyre pressure before seeding. Refer page 5.
- 6 Double check seed rates before seeding.
- 7 Raise the drill out of the ground when making any turns.
- 8 Raise the drill out of the ground before backing up.
- 9 After prolonged storage, check to see that all drive mechanisms and hydraulic equipment are functioning correctly. Check that the seed tubes are not perished or blocked.

Sowing Speed

Typical travel speeds when sowing range from 6-12 km/hr in good conditions. In stoney and uneven ground conditions a lower speed is recommended to minimise rapid part deterioration. Sowing too fast can result in:

- 1 Poor contour following and uneven sowing depth.
- 2 Impact damage to:
 - a Ground engaging components.
 - b Bearings, housings & axles.
 - c Fasteners & structural components.
- 3 More extreme conditions will result in greater vibration and uneven seed flow at low seeding rates.

'Renovator AST6000' General Operation

Operation

AST6000 Hydraulic Operating Instruction

Unfolding

- 1 Connect hydraulic hoses to appropriate tractor outlets, ensure the return line has a free and unrestricted follow back into the tractor.
- 2 **IMPORTANT**, before any hydraulic operation is attempted, the monitor must be connected to a continuous uninterrupted power source.
- 3 **Do not attempt to operate the hydraulics without the monitor power on.**
- 4 Turn on the monitor, when the run page is displayed, you can now operate the hydraulics.
- 5 Raise the machine fully up.
- 6 *Wing Operation*, Step 1 – Bring the wing wheels all the way out before attempting to lower the wings.



Warning: failure to do this will likely cause the machine main wheels to lower the machine unexpectedly!



- 7 *Wing Operation*, Step 2 – The wings may now be lowered when the area is safe to do so. Commanding the wings to lower will simultaneously release the wing locks.

Note: The wing wheels will now work in unison with the machines main wheels to set the sowing depth.

- 8 Turn on the Wing Pressure switch. The hydraulic system will now maintain a pre-set downward pressure on the wings. As a safe starting point, set the tractor flow to be 10%.

Folding machine up for transport

- 1 Fully raise the machine.
- 2 Turn off the wing pressure switch. Fold the wings up, the wing wheels will retract at the same time.
- 3 **While traveling**, leave the monitor power on.
- 4 **When parking**, lower the machine to the ground and turn off the monitor power.

What can go wrong

If an attempt is made to unfold the machine without power to the monitor:

>The wing wheels will move out then the wing Ram pressure will load up and potentially damage the wing locks. The wings would not fall to the ground.

If the monitor power is turned on after an attempt has been made to lower the wings with the power off:

>Once power is connected the wing locks will release and the wings suddenly move away from the locks. The wings would not fall to the ground but the release would be very quick.

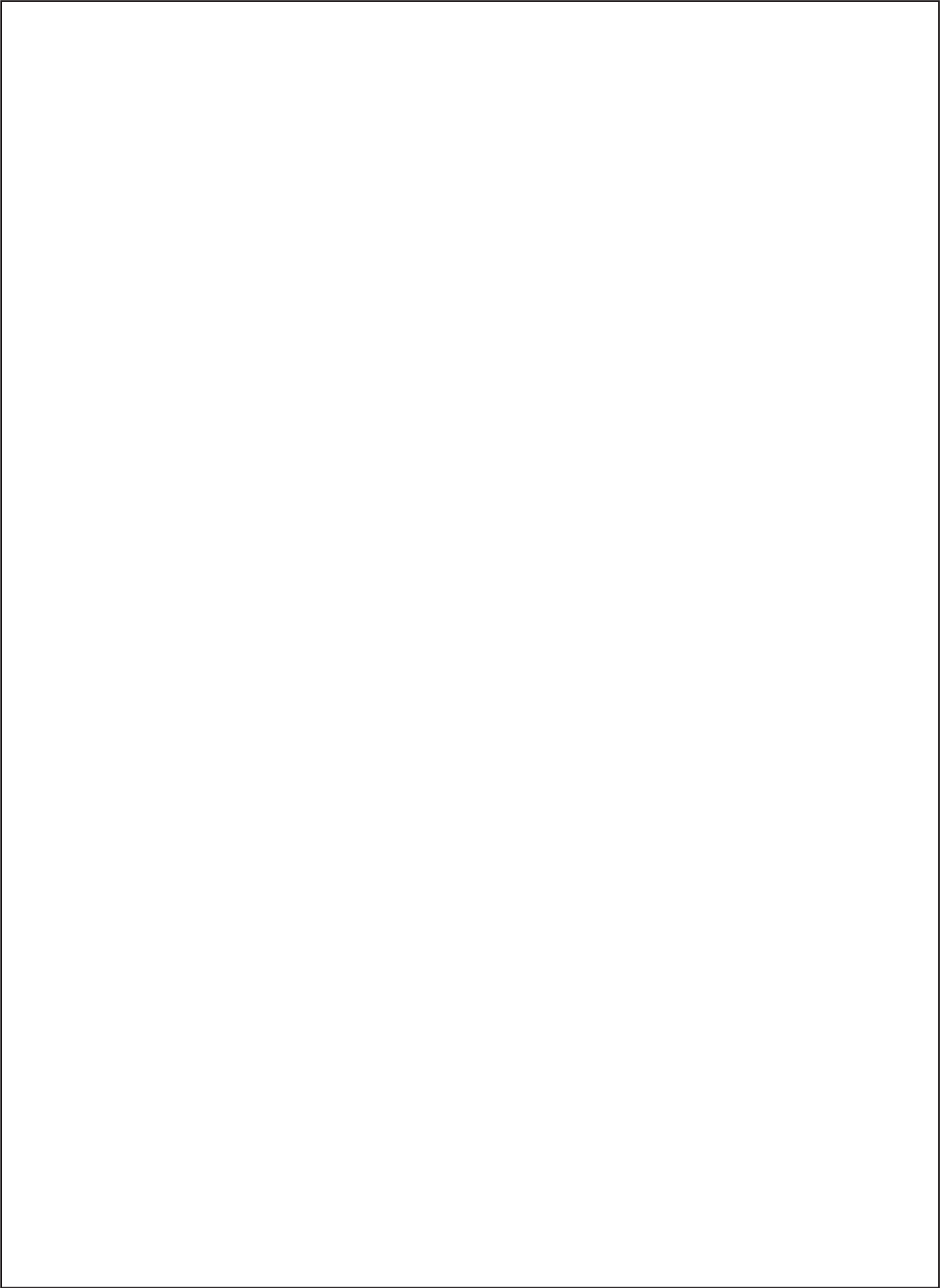

'Renovator AST6000' General Operation

Sowing Depth Control

The sowing depth is dependent on:

- 1 The wheel height in relation to the chassis
- 2 Tyre pressure
- 3 Ground condition i.e. hard or soft

The wheel height in relation to the chassis is controlled using the hydraulic ram depth stop. With the machine raised up, adjust the position of the depth stop.

Transport Position

It is recommended to raise the drill into the transport position when turning at headlands to avoid damage to the ground engaging components.

Wing Hold Pressure Setting

This is used to keep down pressure onto the wings for even sowing depth across the tool bars: this transfers the centre frame weight to the wings in hard conditions.



The wing hold switch must not be activated when the wings are folded ie when the machine is in transport. The switch may only be activated when in the drilling position.

'Renovator AST6000' Read Before Operation

Components Referred to in the Pre-Calibration Setup and Calibration Process

The following pages describe how to set the machine up for calibration, the calibration process and subsequent adjustments to obtain the desired seed and/or fertilizer output.

Terms and words used in those instructions are shown below:-

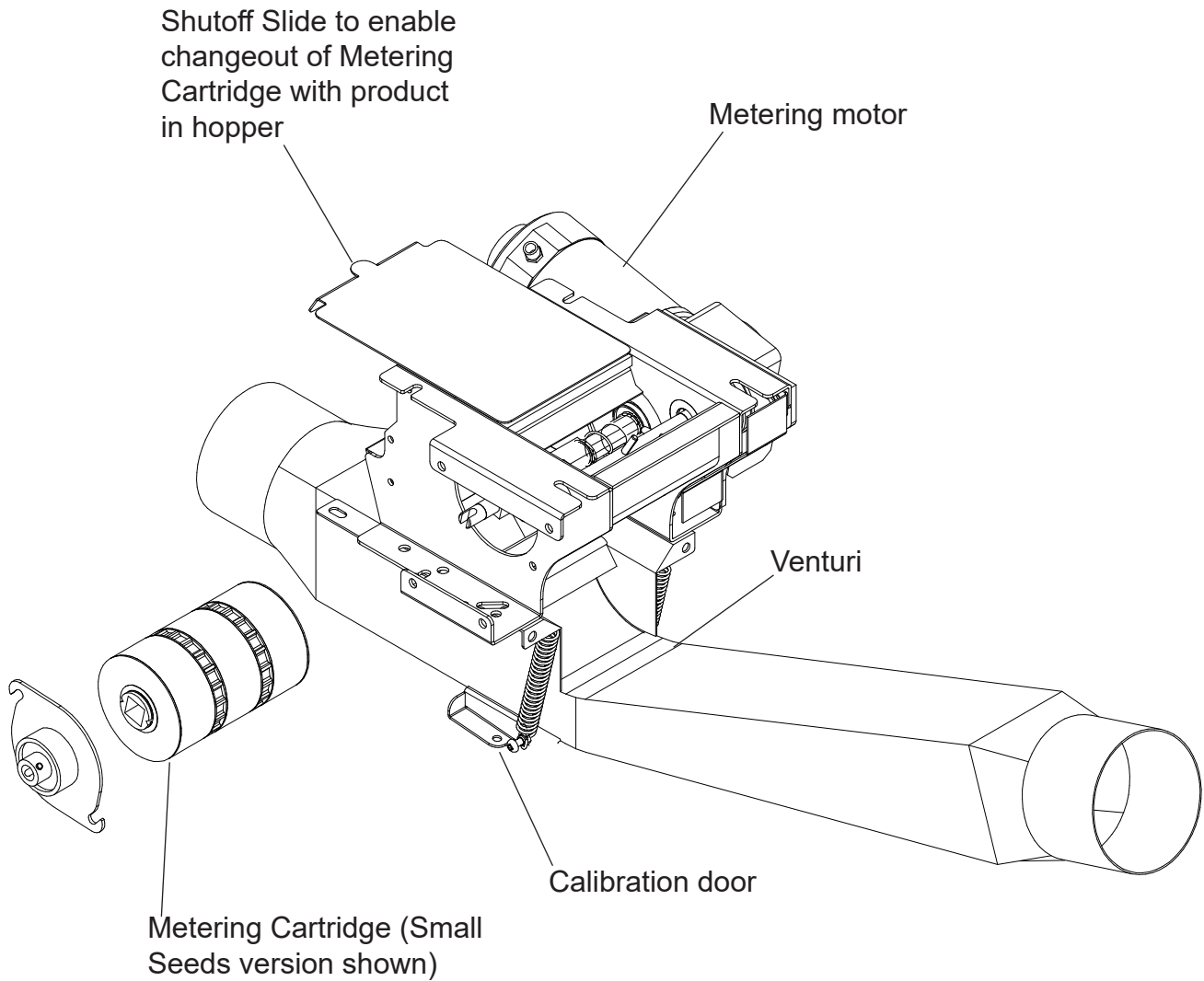

'Renovator AST6000' Read Before Operation

Components Referred to in the Pre-Calibration Setup and Calibration Process

The following pages describe how to set the machine up for calibration, the calibration process and subsequent adjustments to obtain the desired seed and/or fertilizer output.

Terms and words used in those instructions are shown below:-

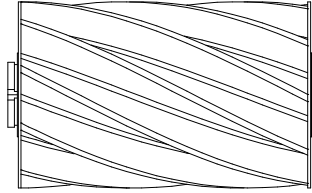

Fertilizer/Beans Cartridge

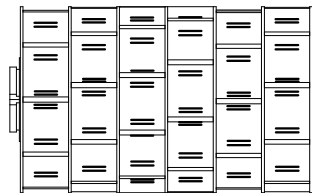

Normal Seeds Cartridge

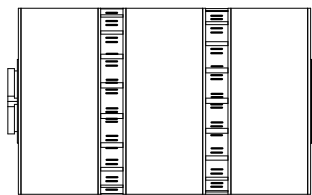

Small Seeds Cartridge

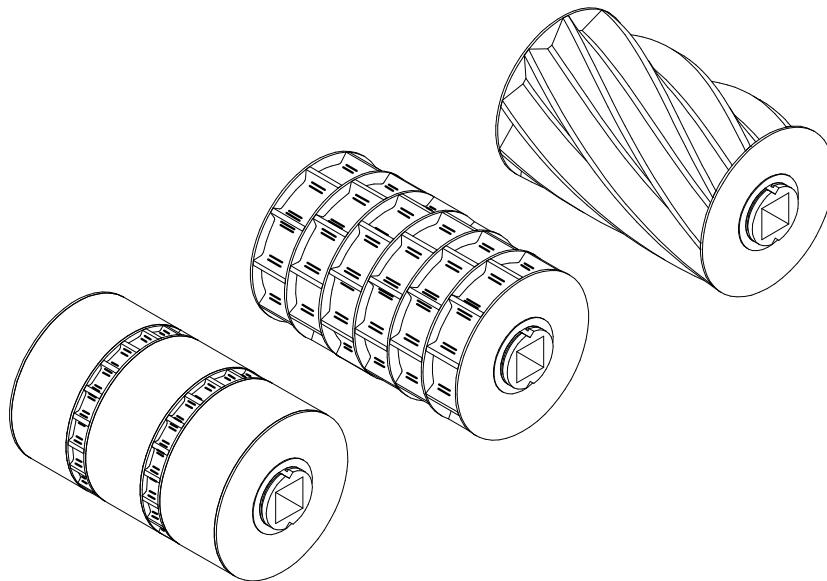

'Renovator AST6000' SmartAG Overview

Front Screen - Overview

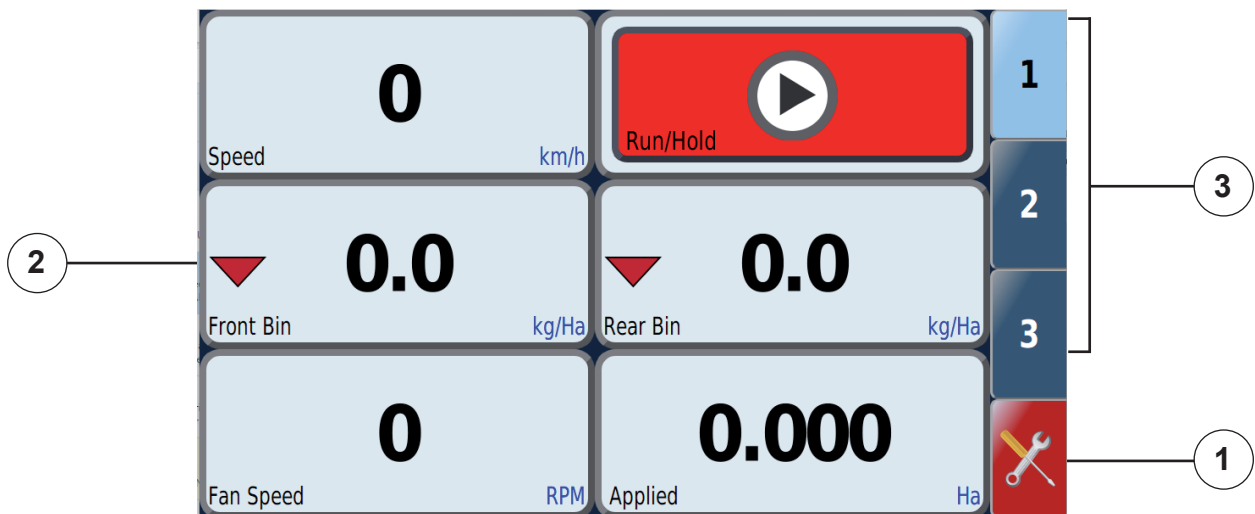

Front Screen

1 Settings Menu

> Select the Settings tab (looks like a wrench) to display the settings menu. This will mostly be used to access the calibration screens which are described in the calibration section of this manual.



2 Display Tiles

>A display tile shows the data for the name of the tile. This can be any input. In this case the screen is setup to display the data relevant to the seed drill.

>Pressing on a display tile can be used to change the setting (if available) for that tile. eg: Press and hold the Front Bin (or Rear Bin) tile for 1 second and you will see the rate for that bin. Use the - or + to change if needed.

>Pressing on the Applied Ha tile allows you to reset the area to zero to record a new job.

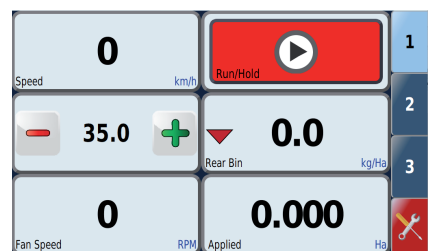

3 Front Screen Tabs

>Different tabs display different sets of display tiles. These are preconfigured but may be customised to your liking.

Note that at any time, the system may be returned to Factory Settings using the supplied USB memory stick.

'Renovator AST6000' SmartAG Overview

Settings Menu - Overview

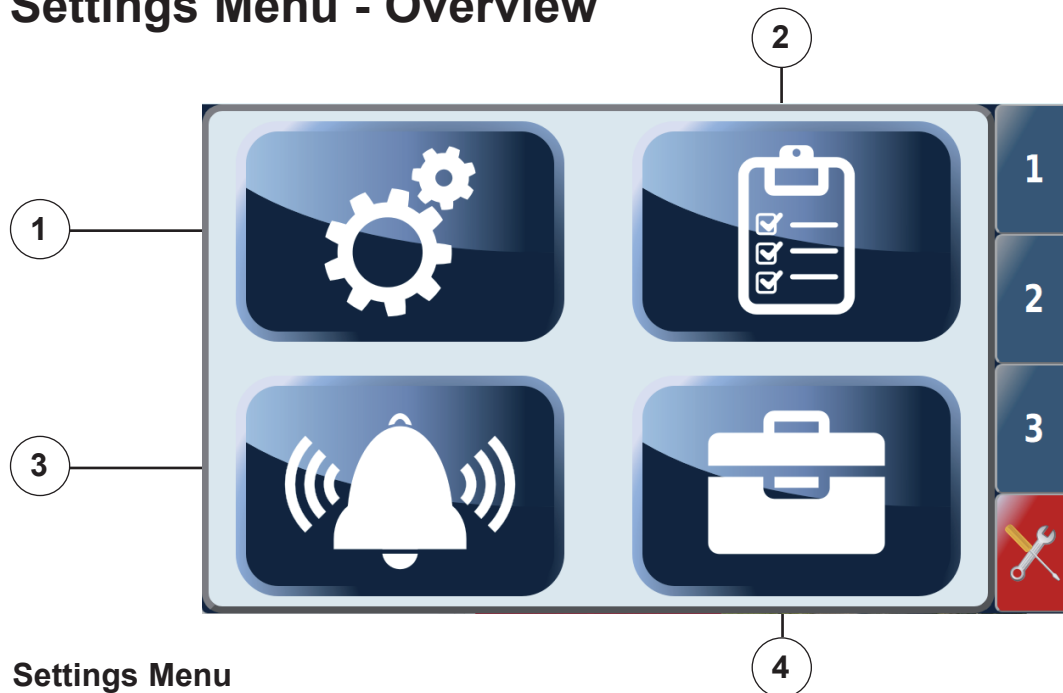

Settings Menu

1 Setup Menu

> This opens the Settings and Setup menu. This enables product calibration, machine settings and display options. Note that all the settings for your machine are already set and tested at the factory.

2 Jobs Menu

> This opens the jobs menu.

3 Alarms Menu

> This opens the alarms menu.

4 Maintenance Menu

> This opens the maintenance menu.

Note that at any time, the system may be returned to Factory Settings using the supplied USB memory stick.

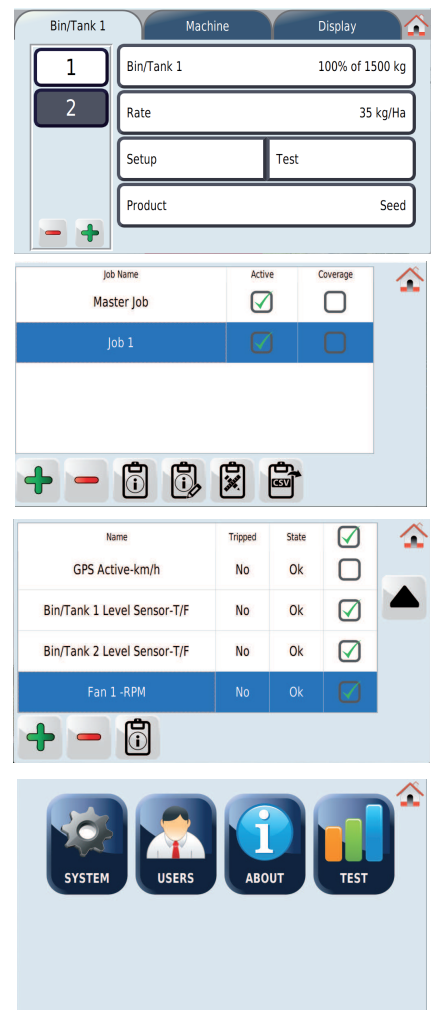

'Renovator AST6000' SmartAG Overview

Screen Tabs - Overview

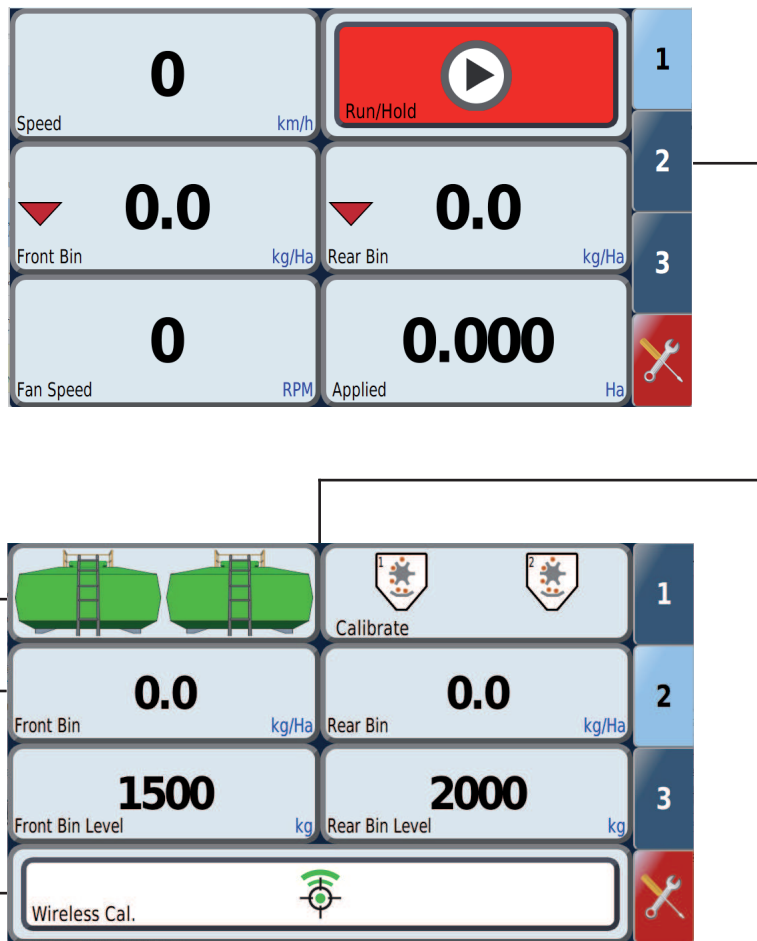

Tab 2 - Bin Contents and Bin Motor 'ON/OFF'

1 Bin Motor ON/OFF

> Quickly touch the bin you wish to toggle ON/OFF. In this picture, the Front Bin is off and is displayed in red.

2 Front/Rear Bin Level Estimate

> The value displayed is a continuous calculation derived from the density of the product (set in the bin setup menu) and the amount (kg) of product metered out. If setup correctly, this will show the amount (kg) of product remaining in the bin.

3 Wireless Calibration

> Touch to enable wireless calibration.

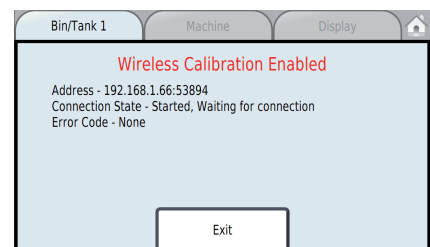
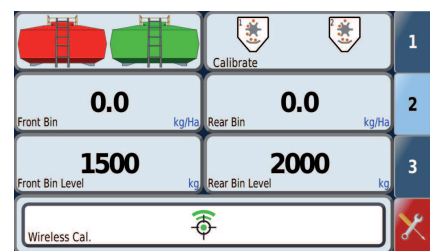

Note that at any time, the system may be returned to Factory Settings using the supplied USB memory stick.

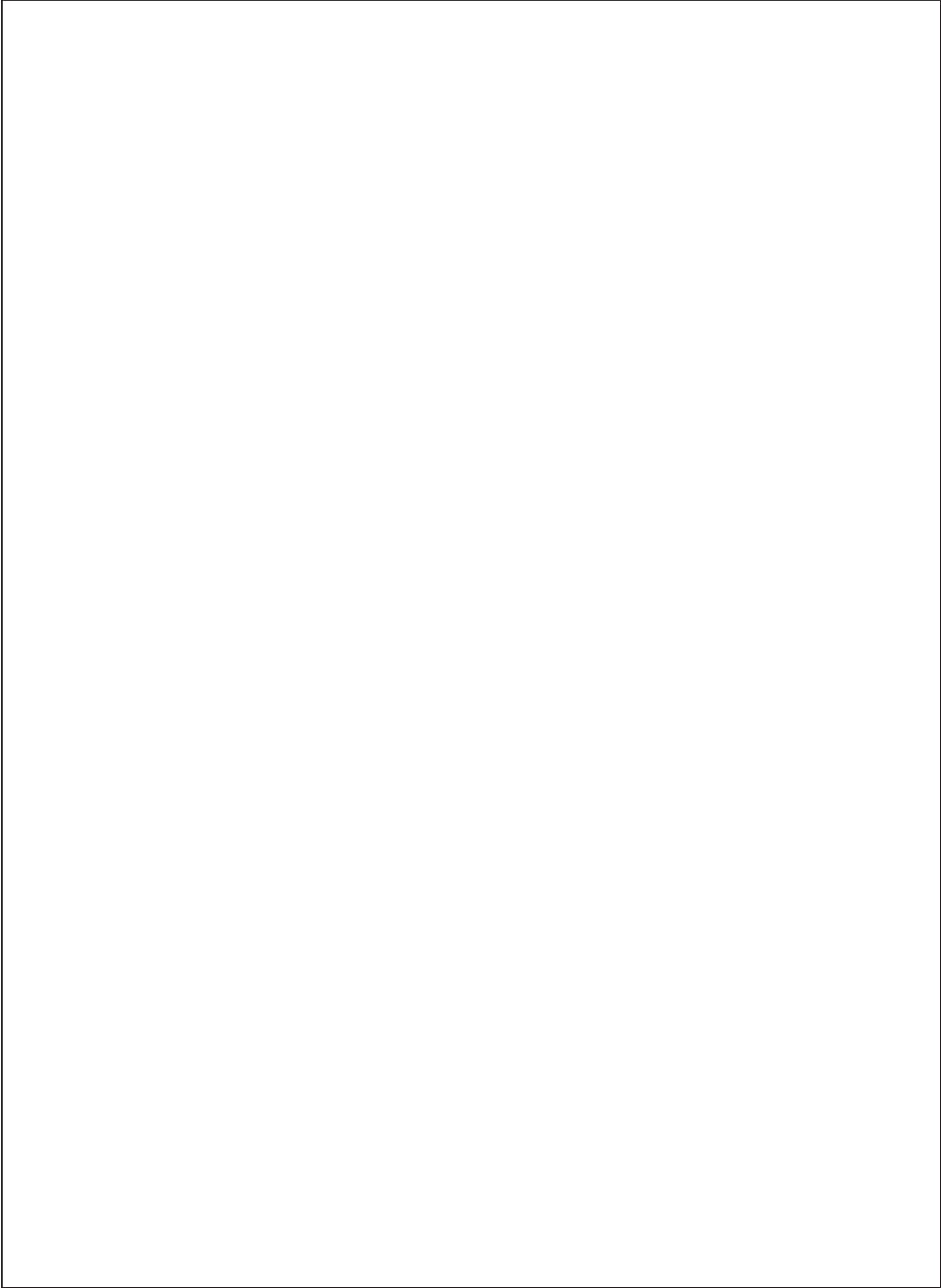

'Reno' AST6000' Pre-Calibration Setup & Sowing Chart

CARTRIDGE	NORMAL	FERTILIZER/ BEANS	SMALL SEEDS
PRODUCT			
Wheat	X		
Oats	X		
Barley	X		
Ryecorn	X		
Peas		X	
Grass	X		
Pasture Mix	X		
DAP		X	
Superphosphate		X	
Lucerne (Alfalfa)	X		X
Turnip			X
Kale			X
Swedes			X
Canola/Rape			X
White Clover			X
Red Clover			X
Grass	X		X
Millet	X		X
Grain Sorghum			X
Forage Sorghum			X
Chicory			X

Fertilizer/Beans Cartridge

Normal Seeds Cartridge

Small Seeds Cartridge

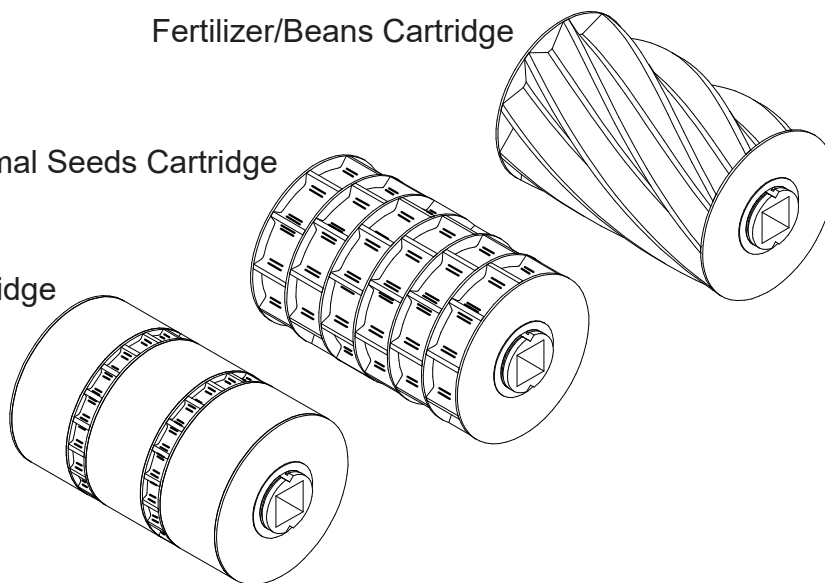

'Renovator AST6000' Read Before Operation

Pre-Calibration Setup

- 1 Empty hoppers and clear old seed and fertilizer from metering unit.
- 2 Select appropriate Metering Roller for the product you intent to sow. Fit the Metering Roller to the metering unit by removing the wing nuts. The Metering Roller may be removed by rotating and removing the cover. Access to the cover is on the opposite side to the Metering Motor.
For a seed not listed in the table, use a metering cartridge for a similar sized seed.
3. Raise the drill prior to calibration.
4. Calibrate the drill (refer to the next section)
5. Set the fan speed and airflow (refer page 32)

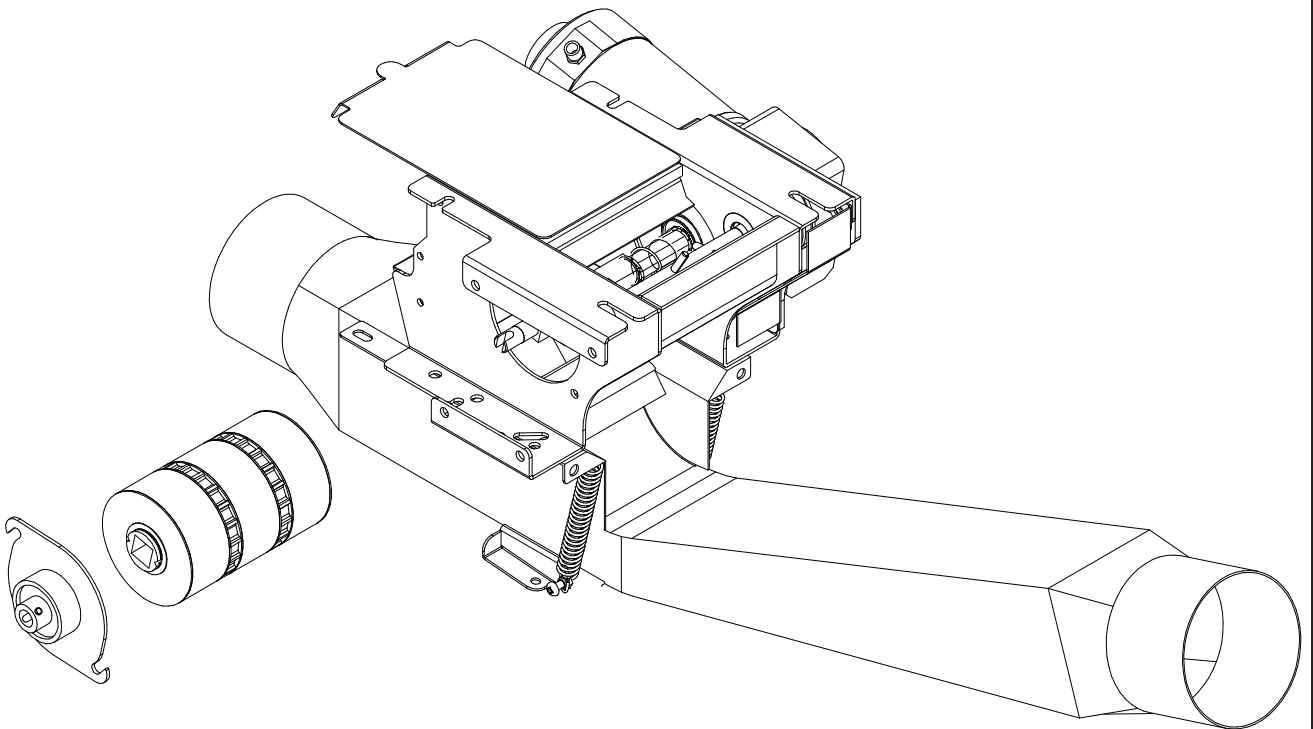

'Renovator AST6000' Calibration

Seed Calibration

The calibration test should be done to confirm the required seed rate to be sown and is done with the drill stationary and level and the fan off.

Seed Calibration Procedures

- 1 Prepare a suitable area for weighing and setup the scales. Tare the scales with the same container that will be used to weight the product. **Scales must be accurate to 2 grams**
- 2 Ensure that the metering unit is free from debris.
- 3 The metering unit should already be fitted with the correct cartridge.
- 4 Fill the appropriate bin. A minimum depth of 300mm is required for calibration with normal seeds.
- 5 Place the calibration container under the metering unit venturi and open the calibration door.
- 6 Return to the tractor to access the SmartAG screen.
- 7 Go to the Bin/Tank tab as shown below.



- 8 Select the Bin that you want to calibrate.
- 9 Select Product to change if required, touch the tick to accept.

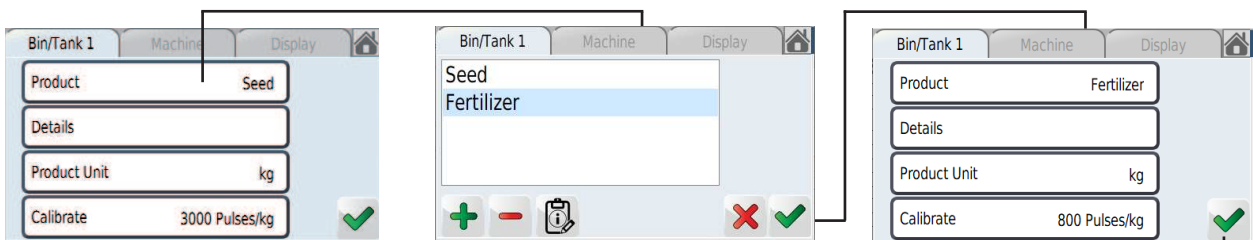

- 10 Touch tick again to accept and return to the Bin/Tank screen.
- 11 Touch Rate to change the Application Rate if required.

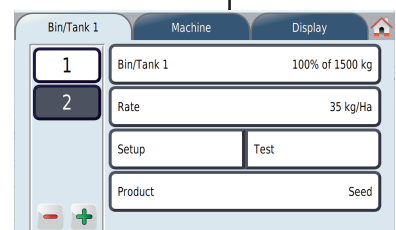

'Renovator AST6000' Calibration

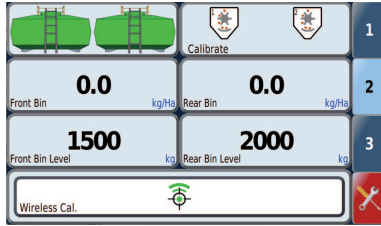

Seed Calibration

With the drill set up for calibration and the display configured for the chosen product we are now ready to calibrate.

- 1 From the main screen, Touch Tab 2
- 2 Touch Calibrate for the required bin.
- 3 Touch Calibration Amount.
- 4 Enter a value for the amount to calibrate. 2kg is a suggested value. If calibrating small seeds a smaller value may be needed to save waiting too long for the calibration to finish. Tick to accept.
- 5 Check that the calibration tray is in place. Press 'play' to start the calibration.
- 6 When the calibration has stopped running, weigh the seed collected. Weigh to an accuracy of 1 gram (0.001kg).
- 7 Touch Measured Amount and enter the value you weighed. Touch tick. It may not be the same as the amount you asked for especially on a new product.

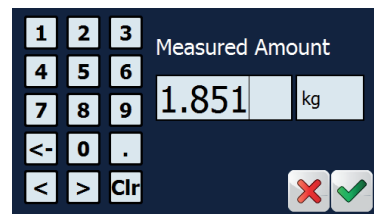
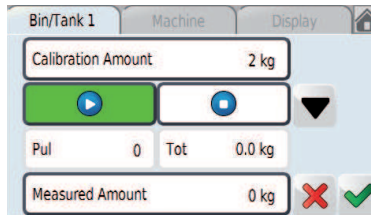
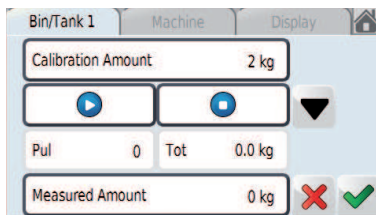
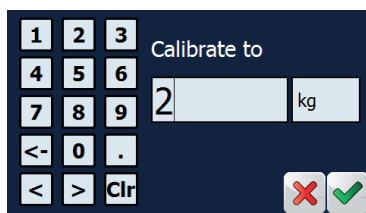
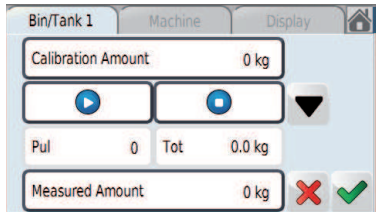

- 8 Touch tick again. Touch OK. Touch tick to accept to return to the Bin/Tank screen. Touch the 'home' icon to return to the main screen.

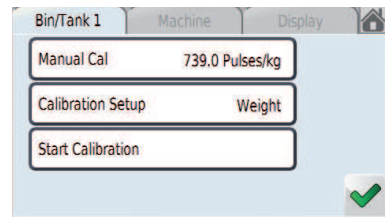
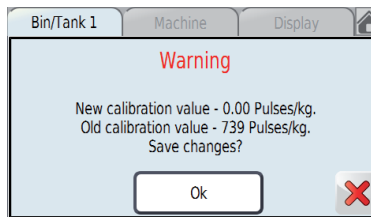
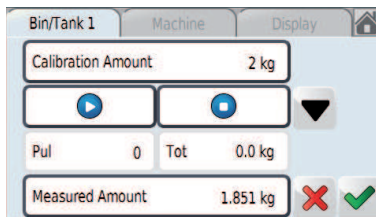

- 9 Note that you may manually enter a calibration factor by touching the Manual Cal button. This is used when the wrong factor is entered and a value is needed to get the motor to turn again. Use 2000 for seed and 650 for fertilizer as a starting point. Tick to accept and tick again to return to the Bin/Tank screen.

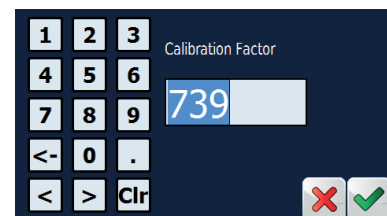

- 10 Touch the 'home' icon to return to the main screen.

'Renovator AST6000' Calibration

Calibration Deviations

Deviations Between the Calibration Test and the Actual Seed Rate

Changes in the flowing properties of seed during sowing often cause changes in the relationship between the calibration test and the seed rate. These changes in flowing properties generally result from reactions of the dressing agents to temperature, humidity or abrasion.

Residues from the seed dressing on the metering wheels can also influence the flowing properties of seed and hence the seed rate. In such cases a balance will occur only after a period of time, and it is recommended that the calibration test be repeated, nominally when the seed box is half empty, to confirm the seed rate after 2-3 seedbox fillings. Only then will a balance occur and the seed rate stabilise.

'Renovator AST6000' Save/Restore>USB



Save Settings and Return to Factory Settings

- 1 Navigate to the Setup screen from the Main Screen by touching the wrench icon.
- 2 Touch the toolbox icon then the SYSTEM icon.
- 3 Touch RESET icon. (This will take you to a menu and does not change any settings)

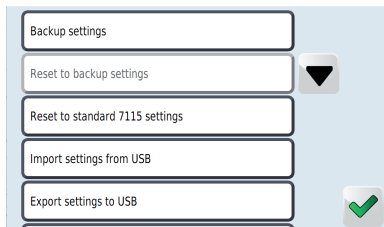
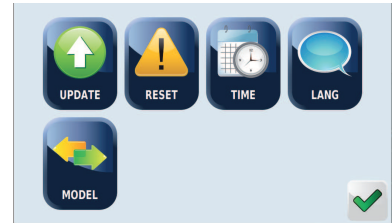
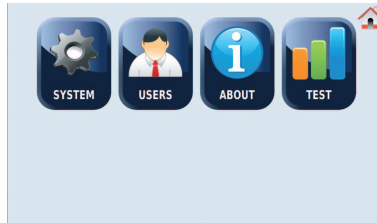

Explanation of Reset menu

- 1 This screen allows the user to save the settings to the screen internal storage, export to a USB memory stick and also to restore settings from a previously saved USB stick. Connect a USB stick to the screen.
 - (i) **Backup Settings**- saves current settings to internal memory. This has already been done at the factory.
 - (ii) **Reset to backup settings**- restores from internal memory
 - (iii) **Reset to standard 7115 screen** -full reset, all settings lost. NOT RECOMMENDED.
 - (iv) **Import settings from USB** - import from USB stick if available.
 - (v) **Export settings to USB** - save settings to USB stick
 - (vi) **Reboot** - restart the screen.

'Renovator AST6000' Airflow & Fan Speed

Airflow and Fan Settings

1. Hydraulic Fan -connect the hoses in the following order:

First - connect Zero pressure Case Drain 3/8" hose (1/2" BSP Female QR) to hydraulic reservoir * Hose marked with short RED wrap.



Second -connect Motor Return 3/4" hose (3/4" BSP Female QR) to tractor high flow low pressure return port. Hose marked with medium length RED wrap.

Finally - connect High Pressure Motor Feed 1/2" hose (1/2" BSP Male QR) to tractor remote. Hose marked with long RED wrap.

Disconnect in the reverse order to prevent motor seal damage.

*The tractor hydraulic reservoir or free drain connection must have zero backpressure.



2. A higher fan speed is usually required to correctly deliver high rate or heavier product such as fertilizer from the front box. The airflow to the rear box is reduced by setting the butterfly valve to the appropriate position as shown in the table. If this is not done the seed delivered to the disc units from the rear box may well bounce out of the seed slot.

The following table shows box fill combinations, butterfly position and recommended fan speeds for normal/fine seeds and fertilizer:-

Box contents		Butterfly Position (affects rear box)	Fan Speed/rpm*
FRONT	REAR		
seed (Normal)	seed (Normal)	open - 5	3000
seed (Normal)	seed (Fine)	closed - 1	3000
Fertilizer	seed (Normal)	closed -2	3000 to 3500
Fertilizer	seed (Fine)	closed - 1	3000 to 3500

* MAXIMUM
PERMISSABLE
FAN SPEED
4000 RPM

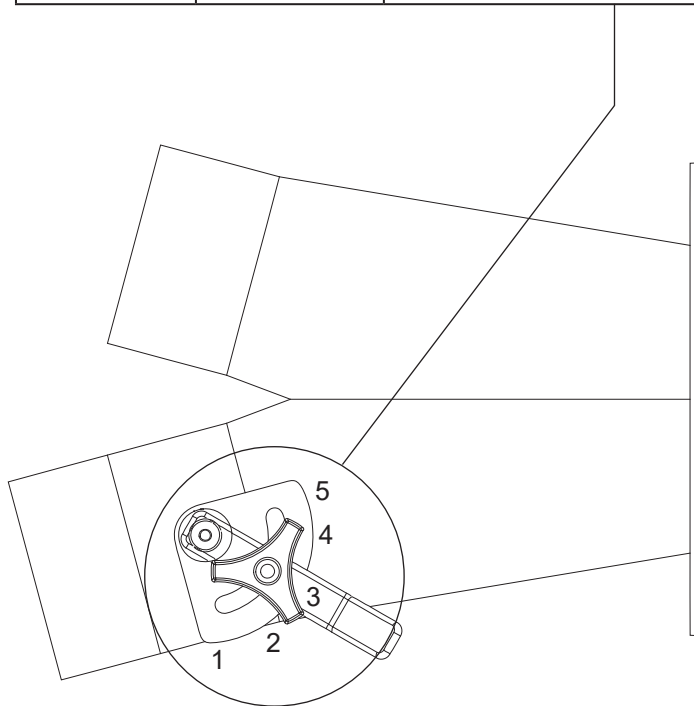

'Renovator AST6000' Maintenance & Care

Maintenance & Care

General Safety and Accident Prevention Advice



- 1 Make sure that if the tractor remains attached to the drill that the ignition key is removed.
- 2 During maintenance the drill should be supported in such a manner that if hydraulic failure was to occur the machine would still be adequately supported.
- 3 Wear gloves when handling components with cutting edges such as worn discs etc...
- 4 Disconnect the electrical supply from the tractor before doing any electrical maintenance.
- 5 Refer to safety sections for more safety information.

General Cautionary Maintenance Advice



- 1 **Electric Welding** - With the electronic equipment in modern tractors it is advisable to completely disconnect the implement from the tractor before attempting any welding.
- 2 **Hydraulics** - Ensure hydraulic couplings (male & female) are clean before connecting. Dirty couplings will result in hydraulic oil contamination and hydraulic cylinder seal and valve damage. This in turn will result in oil leakage.

No filter is fitted to the hydraulic system. If hydraulic fittings and oil supply are not going to be kept clean it is recommended that a filter be fitted to prevent hydraulic cylinder damage.
- 3 **Water Blasting** - Water blasting, steam cleaning or other pressurised cleaning processes can force dirt etc. into undesirable places that may cause damage or rapid part wear to items such as bearings, seals, chains, bushes and electrical items etc.
Caution must be exercised.

'Renovator AST6000' Maintenance & Care

Maintenance & Care - Lubrication Instructions

Precautions with Grease

Greases should not be mixed as the structure may be weakened by the mixes of different types of thickener, which may cause softening and loss of grease from the bearings by running out.



Your new Duncan Renovator AST6000 Seed Drill will give long and efficient service if given normal care and maintained properly.

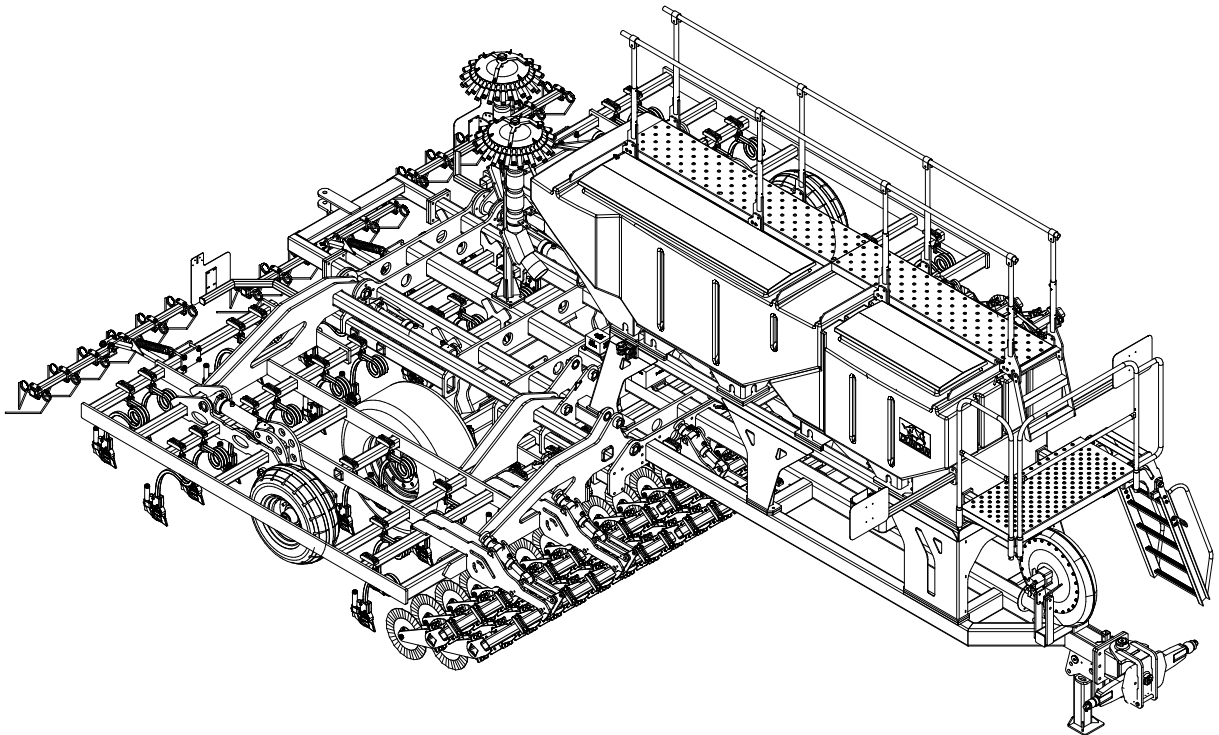

Lubrication Chart

Item	Components	Lubricant	Frequency
1	All Wheel Bearings	Castrol LMX Grease	Annually
2	All Pivot Points, Clevises	Castrol LMX Grease	Weekly
3	Bearing Housings (roller)	Castrol LMX Grease	Weekly
4	Turnbuckle	Castrol LMX Grease	Monthly
5	Coupling	Castrol LMX Grease	Weekly

* The lubrication frequencies are only a guide. Actual frequency will be dependent on extent of use and ground conditions.

'Renovator AST6000' Maintenance & Care

Maintenance & Care - Schedule

Components	Daily	Weekly	Pre Season
	(or after 20Ha)	(or after 75Ha)	(or 500 Ha)
2 point linkage	•	•	•
Metering Units	•	•	•
Pivot Pins incl Ram Clevis		•	•
Pivot Pin Fasteners		•	•
Hydraulics (Oil Leaks)		•	•
Electrics		•	•
Seed Hoses		•	•
Tines & T Boots		•	•
Tyres & Tyre Pressures		•	•
Bolted Connections			•

Maintenance Schedule

(Refer also to Summary Chart, above)

1 Bolted Connections

All bolted connections of the machine should be checked after the first 3 to 5 hours of operation and retightened if necessary and thereafter at regular intervals. It is suggested that this is done every 500 hectares or annually, whichever occurs first.

2 Pivot Pins & Ram Clevis

Pivots must be greased regularly (weekly or after every 75Ha) to provide lubrication and flush out any dirt.

3 Framework

The framework structure should be inspected annually for defects, i.e., cracks in members or welded connections. The framework should be cleaned prior to the inspection.

4 Metering Units

Ensure that the metering units are clean.

'Renovator AST6000' Maintenance & Care

Maintenance Schedule (continued)

5 Fan Hydraulic Motor

Hydraulic Fan -connect the hoses in the following order:

First - connect Zero pressure Case Drain 3/8" hose (1/2" BSP Female QR) to hydraulic reservoir *
Hose marked with short RED wrap.

Second -connect Motor Return 3/4" hose (3/4" BSP Female QR) to tractor high flow low pressure return port. Hose marked with medium length RED wrap.

Finally - connect High Pressure Motor feed 1/2" hose (1/2" BSP Male QR) to tractor remote.
Hose marked with long RED wrap.

Disconnect in the reverse order to prevent motor seal damage.

***The tractor hydraulic reservoir or free drain connection must have zero backpressure.**

6 Preparing the Machine for Storage.





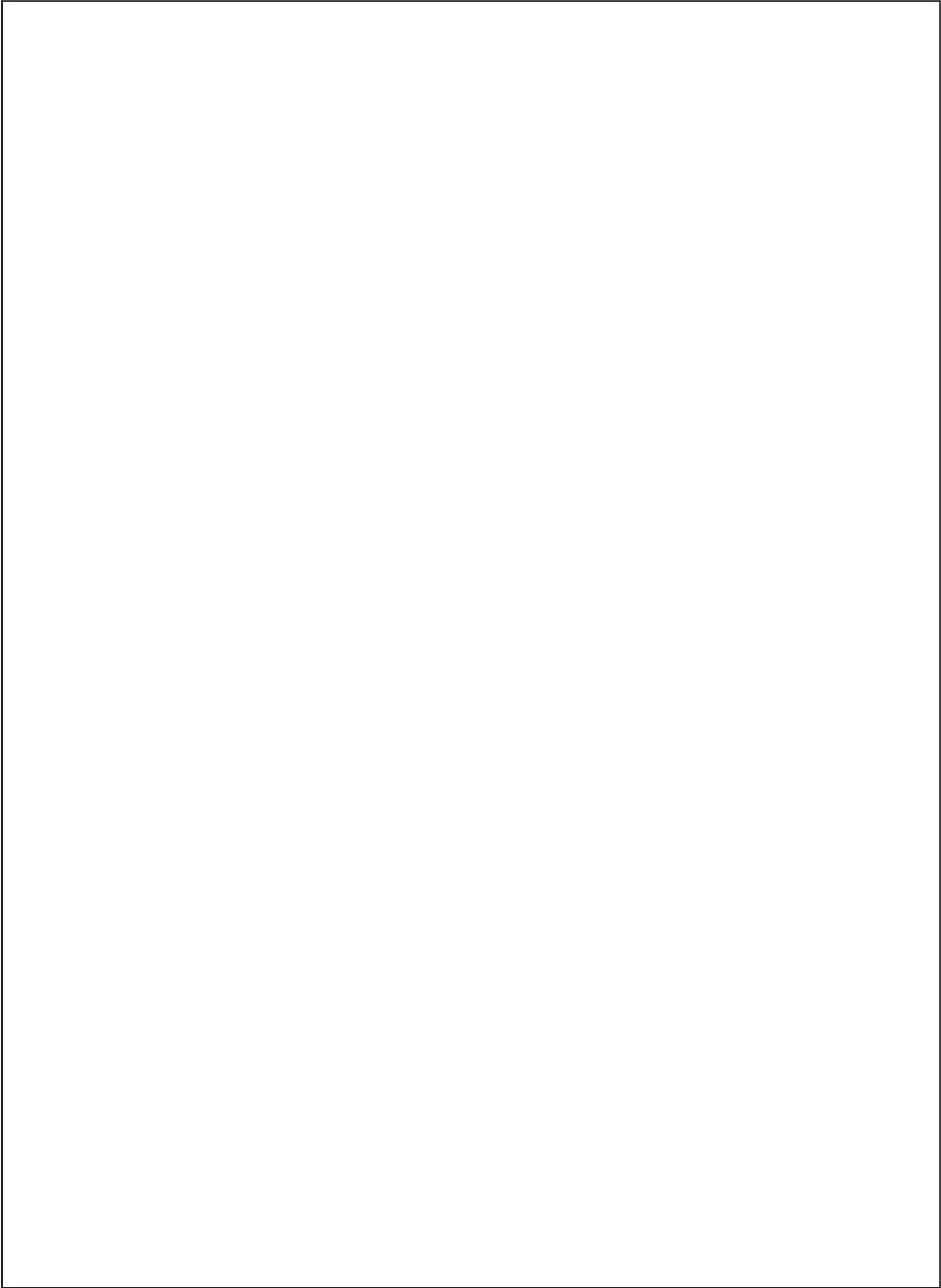

Locate on a dry level surface. The machine should be stored wherever possible so the rams are not supporting any weight. The drive chains should be lubricated with suitable roller chain lubricant before prolonged periods of storage.

It is recommended that maintenance be carried out at the end of the season, giving sufficient time to obtain spare parts and/or carry out repairs if required. The seed and fertilizer bins must be completely emptied and cleaned.



'Renovator AST6000' Hose Connection Colours

Used On...	Hose Function	Wrap Colour	Length/Diameter (mm)	Material Part No.	Description
AS3000/3500/4000, DD30/35/45/50/55, AS53/61	Blower Pressure	RED	350 long Ø25	48089	25mm Coiled Hose Armour/M (RED)
	Blower Return	RED	250 long Ø32	48091	32mm Coiled Hose Armour/M (RED)
	Blower Case Drain	RED	150 long Ø20	48086	20mm Coiled Hose Armour/M (RED)
AS3000/3500/4000, DD30/35, AS53/61	Wheels Lift	BLUE	250 long Ø20	48085	20mm Coiled Hose Armour/M (BLUE)
	Wheels Lower	BLUE	150 long Ø20	48085	20mm Coiled Hose Armour/M (BLUE)
DD45/50/55	Wheels Lift	BLUE	250 long Ø25	48088	25mm Coiled Hose Armour/M (BLUE)
	Wheels Lower	BLUE	150 long Ø25	48088	25mm Coiled Hose Armour/M (BLUE)
AS53/61	Wings Fold Up	YELLOW	250 long Ø20	48087	20mm Coiled Hose Armour/M (YELLOW)
	Wings Fold Down	YELLOW	150 long Ø20	48087	20mm Coiled Hose Armour/M (YELLOW)
DD45/50/55	Wings Fold Up	YELLOW	250 long Ø25	48090	25mm Coiled Hose Armour/M (YELLOW)
	Wings Fold Down	YELLOW	150 long Ø25	48090	25mm Coiled Hose Armour/M (YELLOW)

	Blower RED	Pressure		Hose Connection Colours
		Return		
		Case Drain		
	Wheels BLUE	Lift		
		Lower		
	Wings YELLOW	Fold Up		
	Fold Down	