



Buckton Wagon

Operation & Parts Manual



Disclaimer

While every attempt has been made to ensure that information and diagrams in this manual are correct, Buckton will not be responsible for any damage or consequential loss arising out of misinterpretation or failure to follow recommended procedures; nor will it be liable for any damage caused by, or arising out of, modification or misuse of its product.

For parts or service enquiries, please use the applicable contacts on the previous page.

Printed August 2023

Copyright © 2023 by Buckton.
Printed in New Zealand

All rights reserved. Reproduction or use, without express permission, of editorial or pictorial content, in any manner, is prohibited.

Table of Contents

<u>OPERATING YOUR FORAGE WAGON</u>	5
INITIAL SETUP & OPERATION	5
GENERAL SAFE USE.....	5
<u>MAINTENANCE</u>	6
ADJUSTMENTS	6
LUBRICATION	7
HEALTH & SAFETY MACHINERY RISK ASSESSMENT	8
GENERAL WARNINGS	9
Parts section	11
FLOOR CHAIN ASSEMBLY.....	12
ELEVATOR (ALL MODELS).....	14
CROSS CONVEYOR ASSEMBLY (ALL MODELS)	17
REMOTE HANDLE	19
HYDRAULIC CONTROL BLOCK.....	20
TANDEM AXLE	21
TANDEM AXLE	22
JACK	23
GEARBOX AND HYDRAULIC MOTOR FITMENT.....	24
RT90 GEARBOX	25
RT120 GEARBOX.....	26
RT160 GEARBOX.....	27
RT200 GEARBOX.....	28
LOAD WEIGH SYSTEM	29
TOWING EYES.....	29
HUB ASSEMBLY – ADR.....	30
PANELS.....	32

Introduction

Please read this manual carefully. It contains information vital to the correct maintenance of your machine.

It is the Dealer's obligation to arrange for your machine to be commissioned at the time of delivery by a competent person who will also instruct the operator in its operation under actual working conditions and advise on its care, maintenance and lubrication.

IMPORTANT

When ordering spare parts it is essential that the Model and serial numbers of the machine are quoted as well as the correct part number and part description from this manual.

WARRANTY

Buckton guarantees this implement to give trouble free service under normal use and maintenance and is guaranteed to be free of defects in workmanship and materials for a period of 12 months from the date of purchase.

Should any faults appear, repairs will be carried out free of charge at the discretion of the Manufacturer, by an Authorised Dealer or at the Manufacturer's factory. Warranty only covers the cost of the workman's time actually spent on the repair or fitting of the faulty parts. All cost of Freight, Transport and Travelling costs shall be borne by the user.

No liability will be accepted for consequential losses, delays or damage, or for faults caused by accident, misuse or normal wear and tear.

Faulty parts shall be retained by the Dealer and returned to the Manufacturer if required.

No person, agent or Dealer is authorised to give any warranty on behalf of the Manufacturer, nor to assume for the Manufacturer any other liability in respect of any product unless made in writing from the Manufacturer.

All warranty claims must have prior approval from the Manufacturer, to be made through the Dealer, using warranty claim forms provided by the Manufacturer.

Buckton reserves the right to change specifications and equipment without notice and without obligation to machines already supplied.

OPERATING YOUR FORAGE WAGON

Initial setup & operation

Connect up the hydraulic hoses to the tractor, preferably with a double-acting hydraulic auxiliary valve, or in the case of a single-acting auxiliary, one pressure and one return/dump hose. Before loading and feeding out the first load of silage, engage the hydraulics and rotate the hydraulic control handle anti-clockwise until the floor stops moving forward.

Load the wagon starting at the rear and working towards the elevator.

With the wagon loaded as required and the controls set so that the floor does not move, engage the hydraulics to start feeding. When the silage at the elevator is completely clear with the floor stopped, slowly rotate the hydraulic control handle clockwise until the desired feed rate is achieved. The sensor is now set to your requirements and will not need any further adjustment, unless the feed type is changed. Setting the floor rate too heavy may well cause failure of the elevator system.

For fast rear unloading when harvesting, reverse the hydraulic flow by operating the double-acting auxiliary valve in the other direction or by swapping over the two hoses in the case of single-acting. No adjustments are necessary and the elevator automatically stops. Make sure that the rear door is unlatched. Operate the hydraulics and keep moving forward to prevent build up behind the wagon as you unload.

General safe use

Operating a Buckton Forage Wagon involves several safe work practices, which are also listed in the Machinery Risk Assessment page including:

- !!! Disengage drive and turn off tractor before removing guards or before servicing.
- !!! Read all warning labels on machine.
- !!! Never use your hand to check for oil leaks – to locate small leaks, use a small piece of cardboard, paper or wood.
- !!! Do not ride on machine.
- !!! Stand well clear when operating.
- !!! Do not use machine in steep areas where there is a risk to the operator of a roll-over occurring.

MAINTENANCE

ENSURE CHAINS ARE TENSIONED ON A REGULAR BASIS

Adjustments

Elevator Chains:

- Slacken lock nut and adjust tension to give 40-50mm (1½" to 2") slack in the centre of the elevator chain.
- Re-tighten lock nut.

Floor Chain:

- Slacken lock nuts and adjust tension so that the floor chains in the centre of the top of the floor have 100mm (4") clearance.
- Re-tighten lock nuts.

Cross conveyor belt:

- Belt adjustment, if necessary, should be done at both ends to set 'tracking' correctly.
- To adjust tracking tighten the appropriate adjuster, the belt will run to the side that requires tightening.
- If belt is tracking correctly, and only requires tensioning then adjustment only needs to be made at the discharge end.
- To adjust belt tension at discharge end, tighten adjustment bolts equally, ensuring that the belt continues to run/track in the centre of the conveyor tray. To adjust tracking at drive end, adjust bolt at rear of conveyor so that belt tracks in the centre of conveyor tray.

Wagon Manual

Lubrication

It is essential that the bottom elevator roller sprockets and rear floor shaft sprockets are greased daily for the first week (7 days) of operation. If used initially during harvesting, requiring reversing of the floor, the rear shaft sprockets will require greasing at 3-hourly intervals. Failure to do so in the above instances will result in machine failure.

Thereafter – grease weekly during use, grease nipples located as shown below:

Grease Nipple Location	Number of grease nipples	
	SD 83,100,130,160	SD200
Rear floor shaft sprockets	2	4
Front floor shaft	3	5
Elevator top shaft, (non-drive side)	1	1
Bottom elevator idler sprocket	2	2
Parking jack	2	2
Tandem axle pivot pin (both sides)	4	4

Elevator and floor gearbox oil levels should be checked prior to being used at the beginning of the season. Remove oil level plug, remove filler plug and add EP90 gearbox oil until excess flows out level plug hole. Replace both plugs. If oil leak is noticed at either gearbox, repairs should be carried out immediately to prevent premature gearbox failure.

At the end of the season clean wagon thoroughly and re-grease at all points. Check and/or top up gearbox oil levels and shed store.

POINTS TO WATCH FOR –

- **Tractor and wagon QRCs in good order and oil flow not restricted.**
- **Cross conveyor belt remains free and does not become stuck to unit body because of water and lack of use.**
- **All shafts straight and undamaged.**
- **All chains tensioned periodically if slack.**
- **Wheel bearings and wheel nuts checked seasonally.**

REGULAR LUBRICATION!!!!!!!!!!!!

Health & safety machinery risk assessment

Buckton Forage Wagon



A hazard identification, risk assessment and risk control procedure has been carried out on a representative example of a BUCKTON FORAGE WAGON and where found necessary the appropriate risk control measures have been incorporated in the product specifications. The Operator's Manual contains the necessary information and safety warnings are applied to the machine where necessary.

What is a hazard? A hazard is any situation that may cause injury or illness.

Risk Assessment Rating: Measures the probable frequency of an accident against the potential severity.					
		Severity Potential			
		Fatality	Major Injury	Minor Injury	Negligible Injury
		4	3	2	1
Very likely	4	16	12	8	4
Likely	3	12	9	6	3
Unlikely	2	8	6	4	2
Highly unlikely	1	4	3	2	1
Probable Frequency					

Hazard:	Potential Risk Source	Fr	Sev	Rating	Safety Measure:
Damage to limbs, crushing, abrasions	Moving chains and rotating sprockets	1	3	3	Warning labels/instruction book. Sprockets and chains can only move with drive engaged. Disengage drive prior to servicing or inspecting.
Entanglement, drawing in, trapping	Moving chains, rotating sprockets and bars	1	3	3	Warning labels/ Instruction Book
Damage to fingers/eyes through high pressure fluid ejection	Hydraulic oil pressure leaks	2	2	4	Warning in Instruction Book Adequate pressure ratings for all components.
Instability under varying conditions	Machine Roll-Over	2	4	8	Warning in Instruction Book/Adequate weight on hitch. Do not operate in steep or slippery areas.
Slipping, tripping or falling	Riding on or standing in front of machine	1	3	3	Warning in Instruction Book.
Damage to fingers/eyes through ejection of material	Cross feed conveyor mechanism	1	2	2	Warning in Instruction Book. Warning label.
Crushing or trapping	Movement between tractor and wagon	1	3	3	Parking jack. Do not ride or stand on drawbar. Keep clear when operating.
All the above hazards	Lack of information				Operator's manual outlining safety and correct operating procedures.

General Warnings



**STAND WELL CLEAR
WHILE MACHINE IS
OPERATING**



**DO NOT ENTER
WHILE MACHINE
IS OPERATING**



**MACHINE DRIVE
MECHANISM MUST
BE DISCONNECTED
BEFORE SERVICING**



**ENSURE JACK
IS SECURELY LOCKED
BEFORE UNHOOKING
FROM TRACTOR**



Parts section

FLOOR CHAIN ASSEMBLY.....	12
ELEVATOR (ALL MODELS).....	14
CROSS CONVEYOR ASSEMBLY (ALL MODELS)	17
REMOTE HANDLE	19
HYDRAULIC CONTROL BLOCK.....	20
TANDEM AXLE	21
TANDEM AXLE	22
JACK.....	23
GEARBOX AND HYDRAULIC MOTOR FITMENT.....	24
RT90 GEARBOX	25
RT120 GEARBOX.....	26
RT160 GEARBOX.....	27
RT200 GEARBOX.....	28
LOAD WEIGH SYSTEM	29
TOWING EYES.....	29
HUB ASSEMBLY – ADR.....	30
PANELS.....	32

Floor Chain Assembly

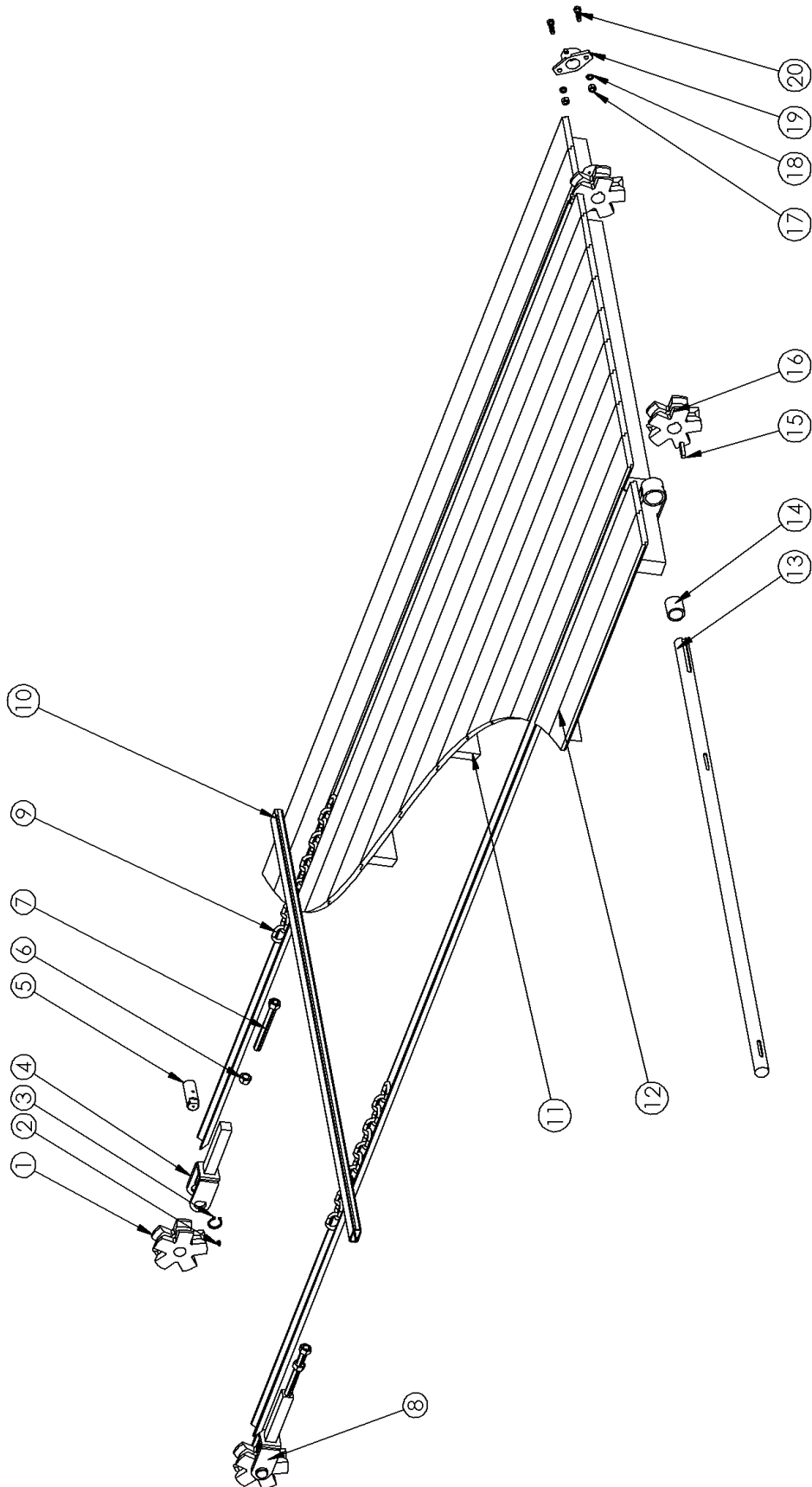

Floor Chain Assembly

Item	Part Number	Description	Qty. SD 83, 100, 130, 160	Qty. SD200
1	C21001	5 tooth rear floor idler sprocket	2	4
2	GRN ¼-ST	Grease nipple ¼" straight	4	8
3	CCE35	Circlip external 35mm	2	4
4	C21003	Sprocket holder	2	4
5	C21002	Rear floor sprocket shaft	2	4
6	N20	M20 Nut	2	4
7	596-1025	Adj tensioner M20x250 SS	2	4
8	50033	Idler sprocket adjuster assembly (contains items 1-7)	2	4
9	PR10	Floor Chain	See table below	
	C22044A	Chain Joiner link	2	2
10	Floor Bar see table below			
11	Timber75x50RS	Cross bearer - 75x50 Rough sawn gum		
12	Timber142x19HW	Decking – 142x19 ship lapped hardwood		
13	C21010	Floor shaft	1	0
13	C21010 200		0	1
14	40x50x50	Shaft oily bush	2	3
15	SK10x10	Key steel 10x10mm @ 55mm long	2	4
16	C21008	5 tooth front floor drive sprocket	2	4
17	N12	M12 Nut	2	4
18	WASG12	Spring washer M12	2	4
19	C21011	Floor shaft bearing	1	2
20	B12x40	M12 x 40 bolt	2	4

Floor Bars

Wagon	Part Number	Quantity
SD 83	C21019	11
SD100	C21019	13
SD130/160	C21019	17
SD 200	C21019 200	42

Floor bar & chain set (supplied with joiner link)

Wagon	Part number
SD83	C21000-83
SD100	C21000-100
SD130/160	C21000-130/160
SD200	C21000-200

Timber

Please measure existing timber before ordering

Cross bearers – Timber75x50RS

Decking – Timber142x19HW

Elevator (All models)

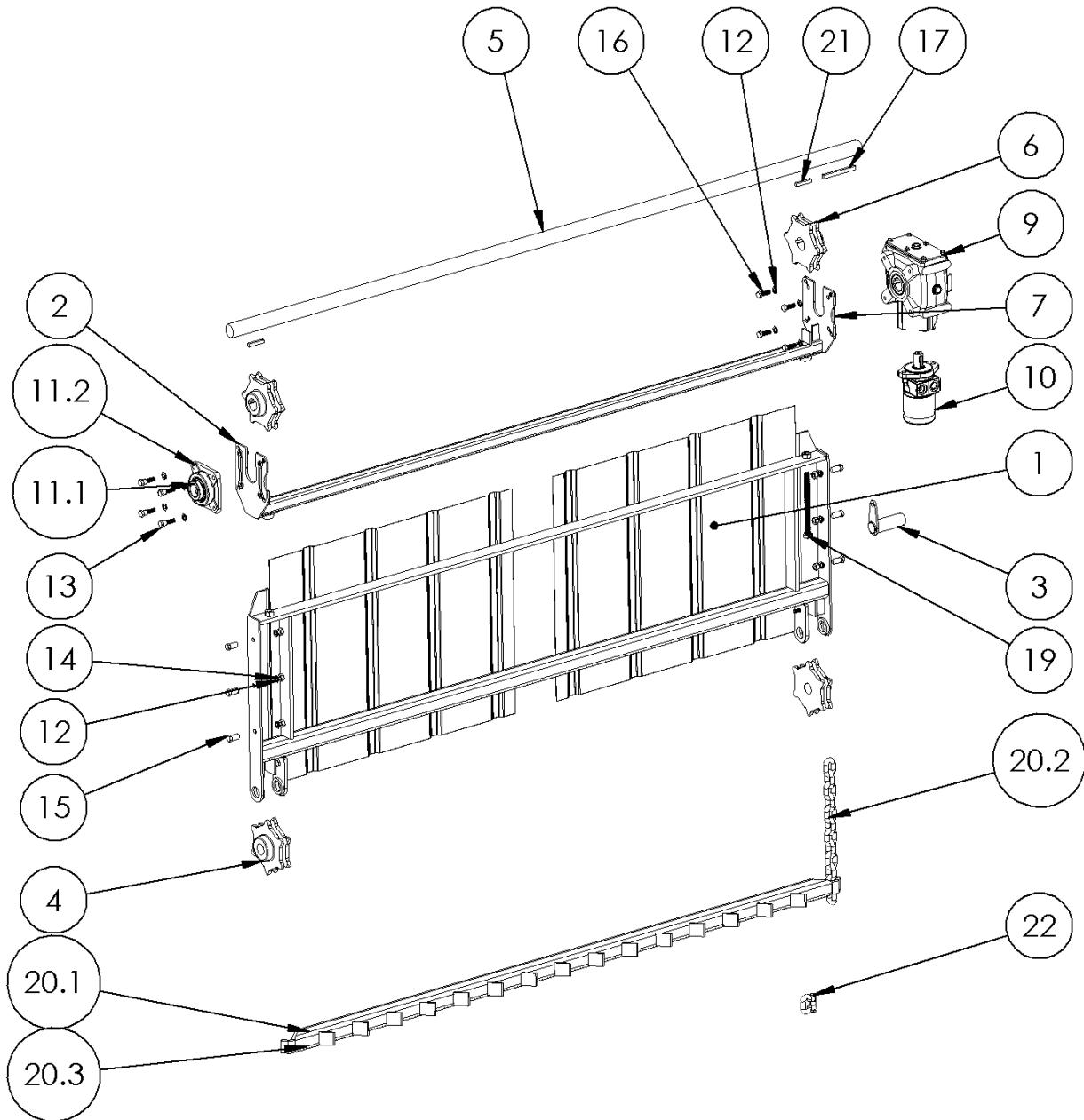

Elevator motors

Wagon Model	Motor Fitted
SD83	HYM195-BUCPT
SD100	HYM260-BUCPT
SD130	HYM260-BUCPT
SD160	HYM330-BUCPT
SD200	HYM330-BUCPT

Elevator (All models)

Table applies to machines with 40mm diameter elevator shaft. For earlier machines with 35mm shaft, see next table

ITEM NO.	PART NUMBER	DESCRIPTION	Qty. SD83, 100, 130	Qty. SD160-200
1	780-1554-PT	Elevator assy	1	0
1	780-1556-PT	Elevator assy	0	1
	C210069	Top Elevator Assembly. Comprises Items 2,5,6,7,11.1,11.2,17,21	1	1
2	C22050-PT	Upper elevator welded assy	1	1
3	50809	Idler Axle Assy - Buckton 2020	2	2
	C22046 pin	Idler Pin – early style. Requires CCE35 35mm Circlip	2	2
4	C22048 35	ELEVATOR IDLER SPROCKET 35MM	2	2
5	C22026 40	elevator shaft 40mm	1	2
6	C22025 40	ELEVATOR DRIVE SPROCKET 40MM	2	2
7	50391K	Dogbone spacer kit, (kit contains 4 spacers, welded on new machines, available as spare for old models)	1	1
9	GBRT120/40- BUCPT	gearbox	1	1
10	Motor (see below)	Hydraulic motor (see below)	1	1
11.1	BRGYET208	BRG insert w/COLL 40mm	1	1
11.2	HSGF208	4 bolt flange housing 40mm	1	1
12	WASG12	M12 Spring Washer	18	18
13	B12X45	M12X45	4	4
14	N12	M12 Nut	10	10
15	B12X30	M12X30	6	6
16	B12X35	M12X35	4	4
17	SK12X8 by 120	Key Steel 12 X 8 by 120	1	1
19	B16X200	M16X200	2	2
20	C22045S	Chain + bar set SD83 - 130	1	0
20	C22045L	Chain + bar set SD160 - 1200	0	1
20.1	C22043	RH Elevator bar (spikes offset to right when holding bar in front of you with spikes facing you)	3	4
20.2	PR10	10mm high tensile floor & elevator chain	51 links (2.05m)	64 links (2.52m)
20.3	C22043-1	LH Elevator bar (spikes offset to left when holding bar in front of you with spikes facing you)	3	4
21	SK10X8 by 55	Key Steel 10 X 8 by 55	2	2
22	C22044A	Chain Joiner link	2	2

Elevator Supplement (Models with 35mm driveshaft)

ITEM NO.	PART NUMBER	DESCRIPTION	Qty. SD83, 100, 130	Qty. SD160-200
5	C22026 35	elevator shaft 35mm	1	2
6	C22025 35	ELEVATOR DRIVE SPROCKET 35MM	2	2
9	GBRT90/35- BUCPT	gearbox	1	1
11.1	BRGYET207	BRG insert w/COLL 35mm	1	1
11.2	HSGF207	4 bolt flange housing 35mm	1	1

Cross Conveyor Assembly (All models)

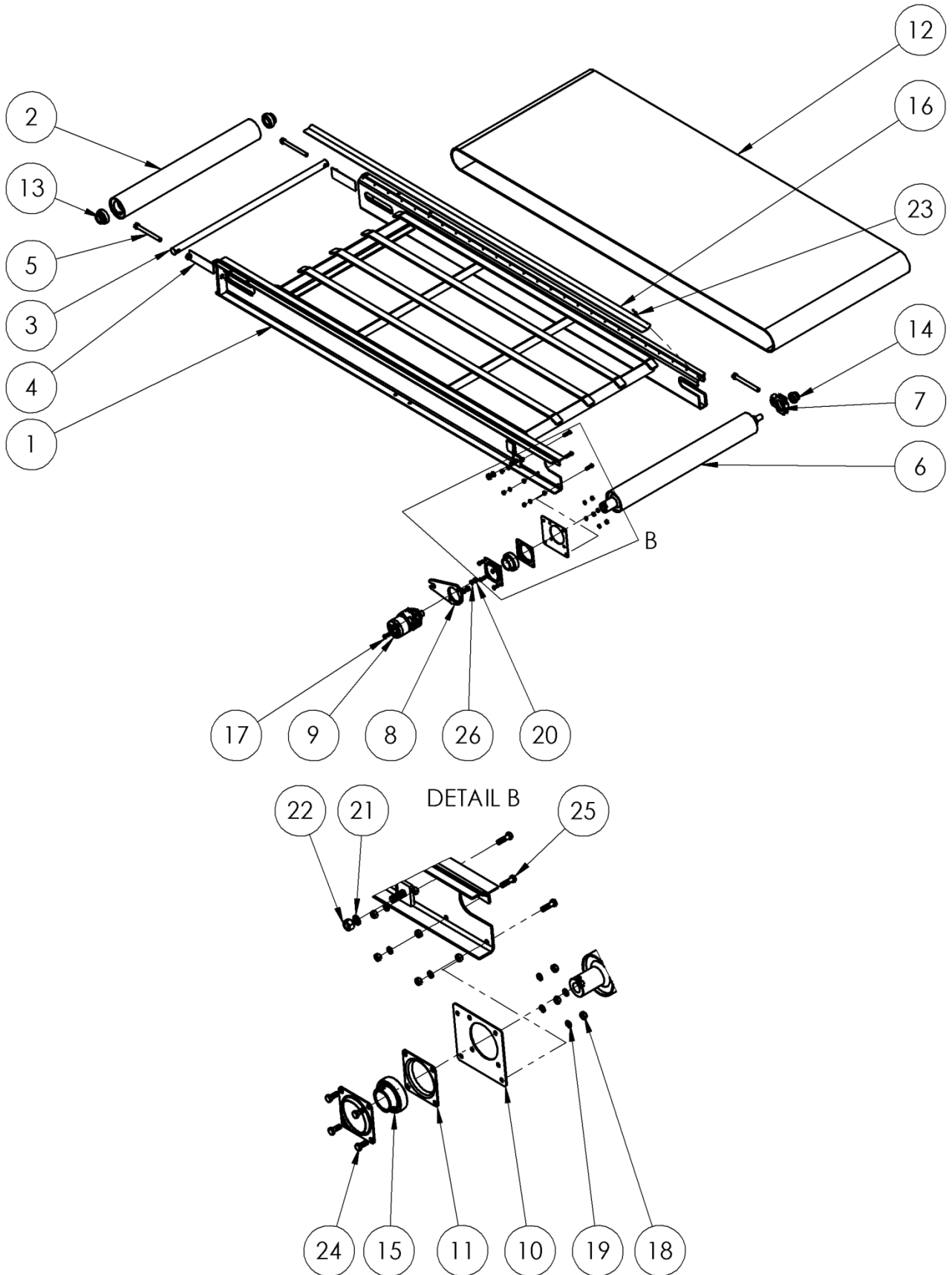

Cross Conveyor Assembly (All models)

ITEM NO.	PART NUMBER	DESCRIPTION	QTY
	Whole assembly	CCBED-BUCKTON (motor not included)	
1	780-BUC BED	BUCKTON BED ONLY	1
2	S13062-1	IDLER ROLLER ASSEMBLY	1
3	S13061	SHAFT	1
4	780-2006	ADJUSTER NUT SLIDE	2
5	596-1004 adj screw	ADJUSTER SCREW	3
6	S13056-1	DRIVE ROLLER ASSEMBLY	1
7	HSGTU505	TAKE UP HOUSING 25mm	1
8	BUC-095	MOTOR MOUNT	1
9	HYM65-BUCPT	Hydraulic motor 65cc 25mm shaft	1
10	BUC-047	CONVEYOR BEARING MOUNT	1
11	BUC-048	CONVEYOR BEARING SHELL	2
12	S13063-900-5.00	CONVEYOR BELT 0.9 x 5.0m	1
13	BRGYET207	BRG INSERT w/COLL 35mm	2
14	BRGYET205	BRG INSERT w/COLL 25mm	1
15	BRGYAR210-2F	BRG INSERT 50mm	1
16	60x3.2 UMPY	C/C BED STRIP - Buckton	2
17	B12X40	M12X40 Bolt	2
18	N10	M12 Nut	10
19	WASG10	Spring Washer	7
20	N12	M12 Nut	2
21	WA16	M16 Washer	1
22	N16	M16 Nut	1
23	RIVIT-SSP-6-5	RIVIT SSP 6-5	52
24	B10X25	M10X25 Bolt	4
25	B10X35	M10X35 Bolt	3
26	WASG12	M12 Spring Washer	2

Remote Handle

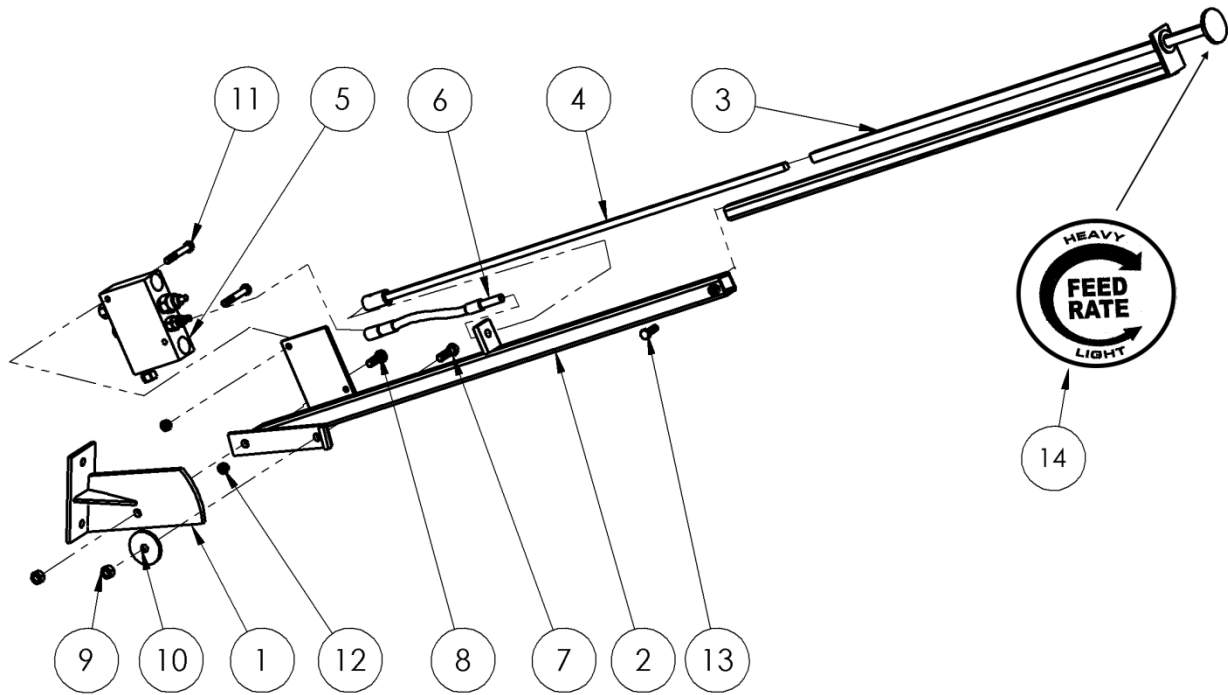

ITEM NO.	PART NUMBER	DESCRIPTION	QTY
1	50141	Remote Mount Bracket	1
2	50142	Remote Handle Outer	1
3	50472	Remote Handle Inner	1
2&3 combined	780-BUC REMOTE MOUNT	Remote handle inner & outer	
4	780-2005	Buckton-s/valve adj-inner Rod	1
5	HYHCV-2138A	Control Valve Block - Bucktons	1
6	REMOTE HOSE	Remote Hose - Bucktons	1
7	B12X40	M12X40 Bolt	1
8	B12X35	M12X35	1
9	N12	M12 Nut	2
10	REMOTE WASHER	Remote Washer - Bucktons	1
11	B10X70	M10X70	2
12	N10	M12 Nut	2
13	B10X30	M10X30	1
14	995-1209	Feed rate decal	1

Hydraulic Control Block (Part number HYHCV-2138A)

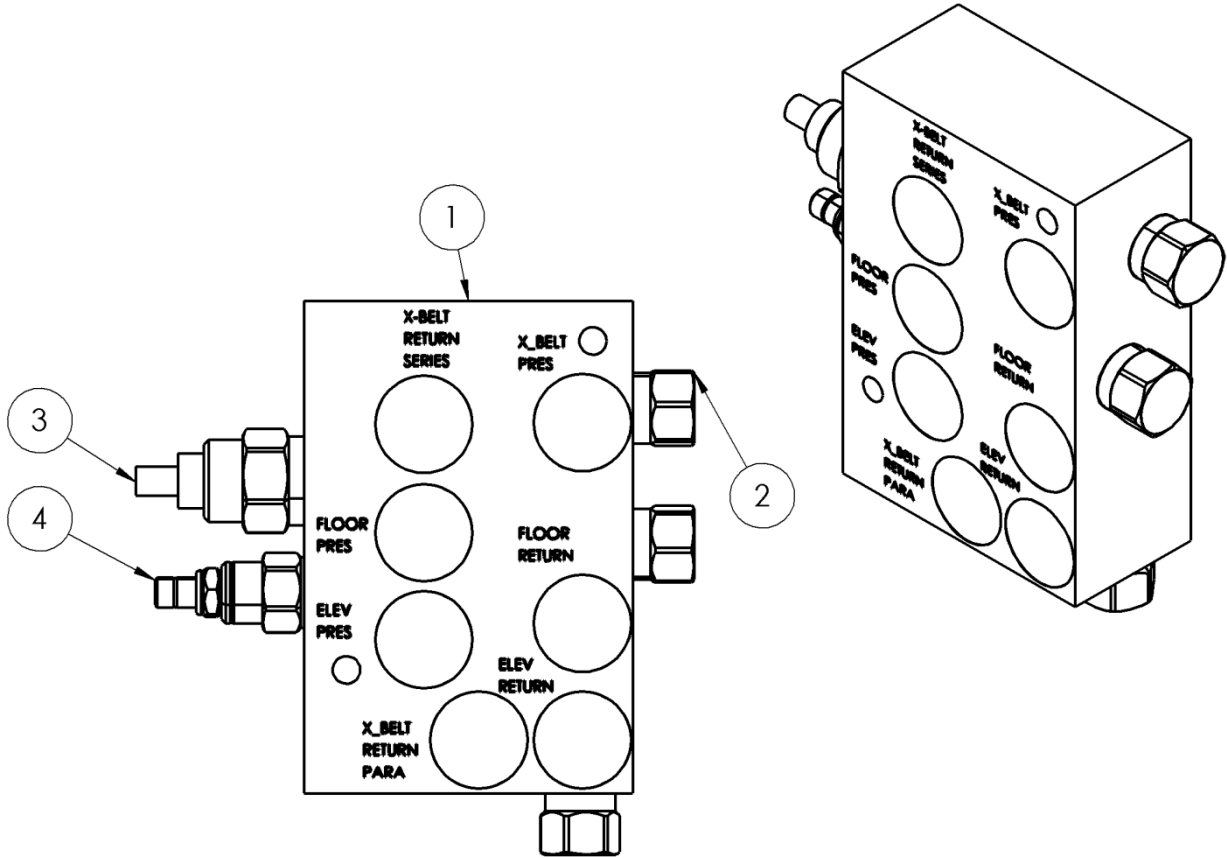

Item	Quantity	Supplier part #	Description	Setting
1	1	HCV 2138A	Manifold block	-
2	3	CXDA XAN	Check valve	4psi
3	1	FRDA LAN	Flow control	20 LPM
4	1	RSDC LCN	Sequence valve	-

Tandem Axle

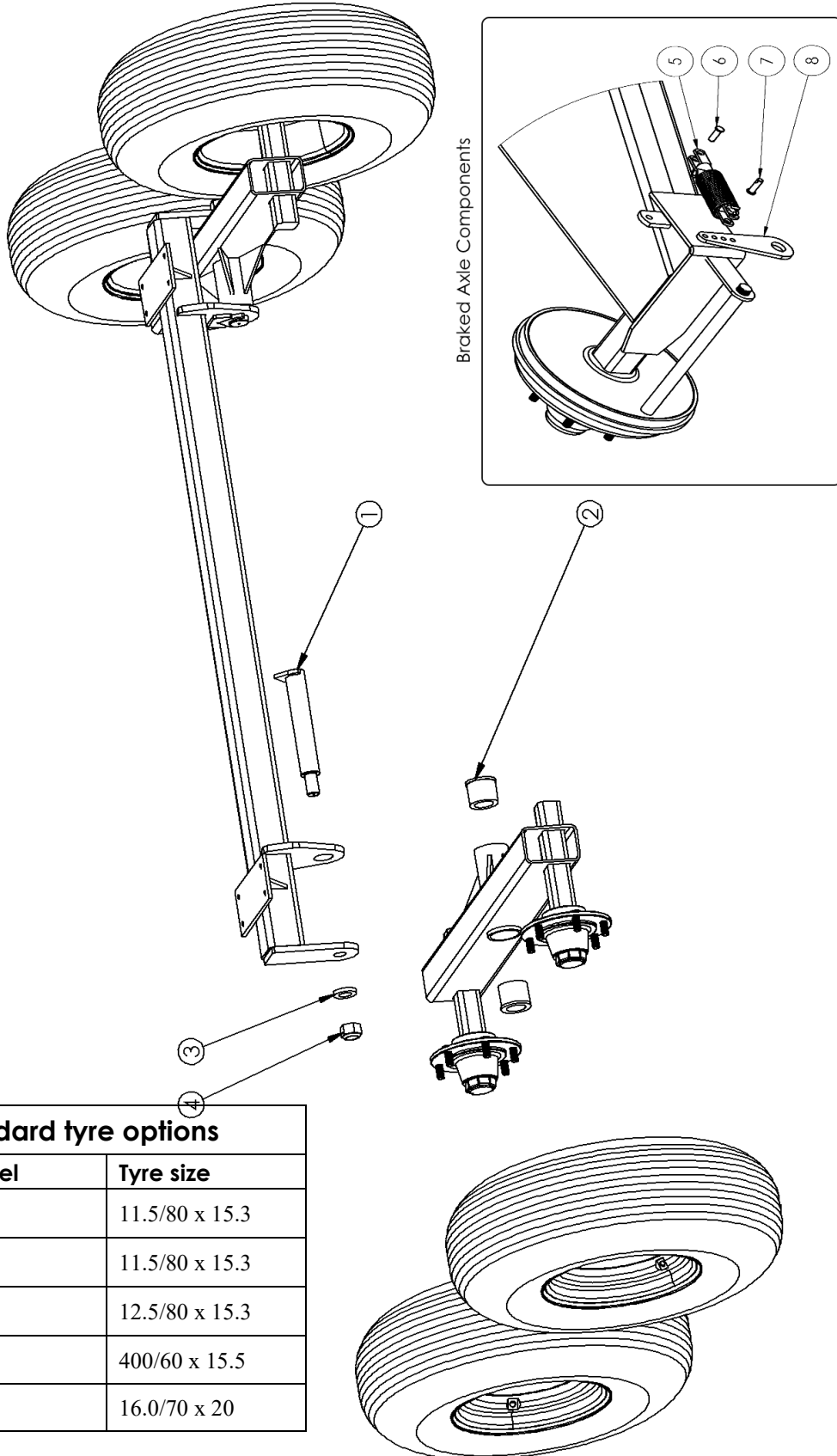

Standard tyre options	
Wagon model	Tyre size
SD83	11.5/80 x 15.3
SD100	11.5/80 x 15.3
SD130	12.5/80 x 15.3
SD160	400/60 x 15.5
SD200	16.0/70 x 20

Tandem Axle

Tandem SD83/100 – Part # AXLEOT-SD83/100			
Item	Part #	Description	Quantity
1	BESAP	Standard axle pin	2
2	C28176	Flanged tandem axle pivot bush	4
3	WA30	Axle pivot washer	2
4	NNF1-1/4	Nyloc nut UNF 1-1/4" Buckton axle	2

Tandem SD130/160 – Part # AXLEOT-SD130/160			
Item	Part #	Description	Quantity
1	BEAPHD	Heavy duty axle shaft	2
2	C28176	Flanged tandem axle pivot bush	4
3	50045	Axle pivot washer	2
4	NNF1-1/4	Nyloc nut UNF 1-1/4" Buckton axle	2

Tandem braked SD130/160 – Part # AXLEOT-SD130/160B			
Item	Part #	Description	Quantity
1	BEAPHD	Heavy duty axle shaft	2
2	C28176	Flanged tandem axle pivot bush	4
3	50045	Axle pivot washer	2
4	NNF1-1/4	Nyloc nut UNF 1-1/4" Buckton axle	2
5	RAMADRD030/025	Ram brake cylinder D030/025	2
6		Clevis pin 13.8 x 41.3 3mm through hole	1
7		Clevis pin 13.8 x 44 8mm through hole	1
8		Brake actuation arm	1

Tandem SD200– Part # AXLEOT-SD200			
Item	Part #	Description	Quantity
1	BEAPHD	Heavy duty axle shaft	2
2	C28176	Flanged tandem axle pivot bush	4
3	50045	Axle pivot washer	2
4	NNF1-1/4	Nyloc nut UNF 1-1/4" Buckton axle	2
5	RAMADRD030/025	Ram brake cylinder D030/025	2
6		Clevis pin 13.8 x 41.3 3mm through hole	1
7		Clevis pin 13.8 x 44 8mm through hole	1
8		Brake actuation arm	1

Jack

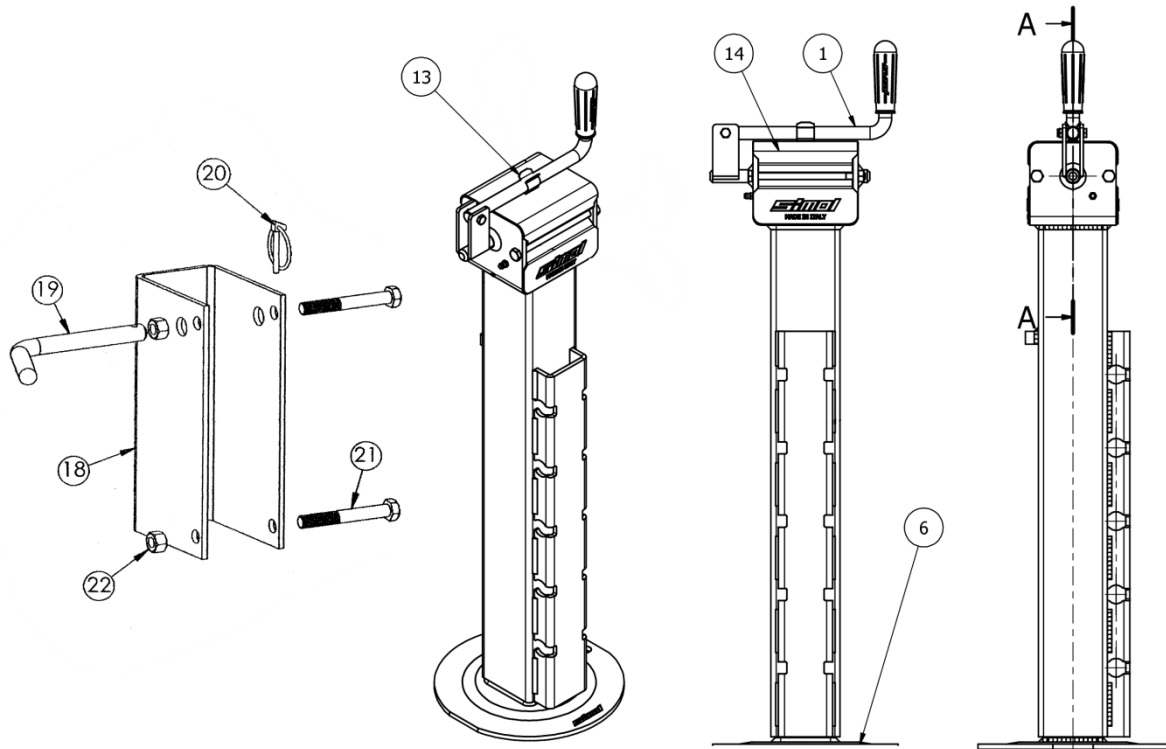

Sez.A-A (1 : 1.5)

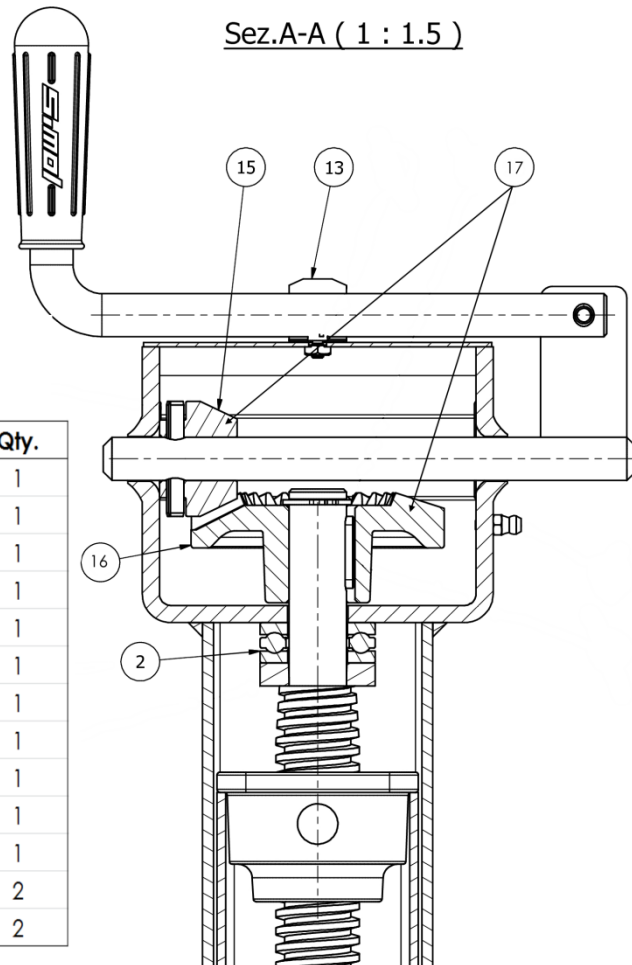

Item	Part #	Description	Qty.
1	301-4056-1	Handle	1
2	301-4060-1	Bearing	1
6	301-4061-1	Inner tube, foot & spindle	1
13	301-4062-1	Spring clip	1
14	301-4063	Top cover	1
15	301-4058-1	Gear small	1
16	301-4059-1	Gear large	1
17	301-4064	Gear pair (small & large)	1
18	301-4100	Jack sleeve	1
19	301-4200	Sleeve pin	1
20	FP10.006	Lynch pin	1
21	B16x100	Bolt, M16x120	2
22	NN16	Nut, Nyloc M16	2

Gearbox and Hydraulic Motor Fitment

GEARBOX & HYDRAULIC MOTOR FITMENT					
WAGON MODEL	SD83	SD100	SD130	SD160	SD200
FLOOR GEARBOX PART NUMBER	GBRT160	GBRT200-45	GBRT200-45	GBRT200-45	GBRT200-45 (X2)
FLOOR MOTOR (CC)	HYM260-BUCPT	HYM195-BUCPT	HYM195-BUCPT	HYM260-BUCPT	HYM260-BUCPT (x2)
ELEVATOR GEARBOX PART NUMBER	GBRT120/40	GBRT120/40	GBRT120/40	GBRT120/40	GBRT120/40
ELEVATOR MOTOR (CC)	HYM195-BUCPT	HYM260-BUCPT	HYM260-BUCPT	HYM330-BUCPT	HYM330-BUCPT
CROSS CONVEYOR MOTOR (CC)	HYM65-BUCPT	HYM65-BUCPT	HYM65-BUCPT	HYM65-BUCPT	HYM65-BUCPT

HYDRAULIC MOTOR INFORMATION				
BUCKTON PART#	CUBIC"	CC	SHAFT	Seal Kit
HYM65-BUCPT	4"	65	25mm	HYMTD/E-SLK
HYM195-BUCPT	12"	195	25mm	HYMTD/E-SLK
HYM260-BUCPT	16"	260	25mm	HYMTD/E-SLK
HYM330-BUCPT	20"	330	25mm	HYMTD/E-SLK

RT90 Gearbox

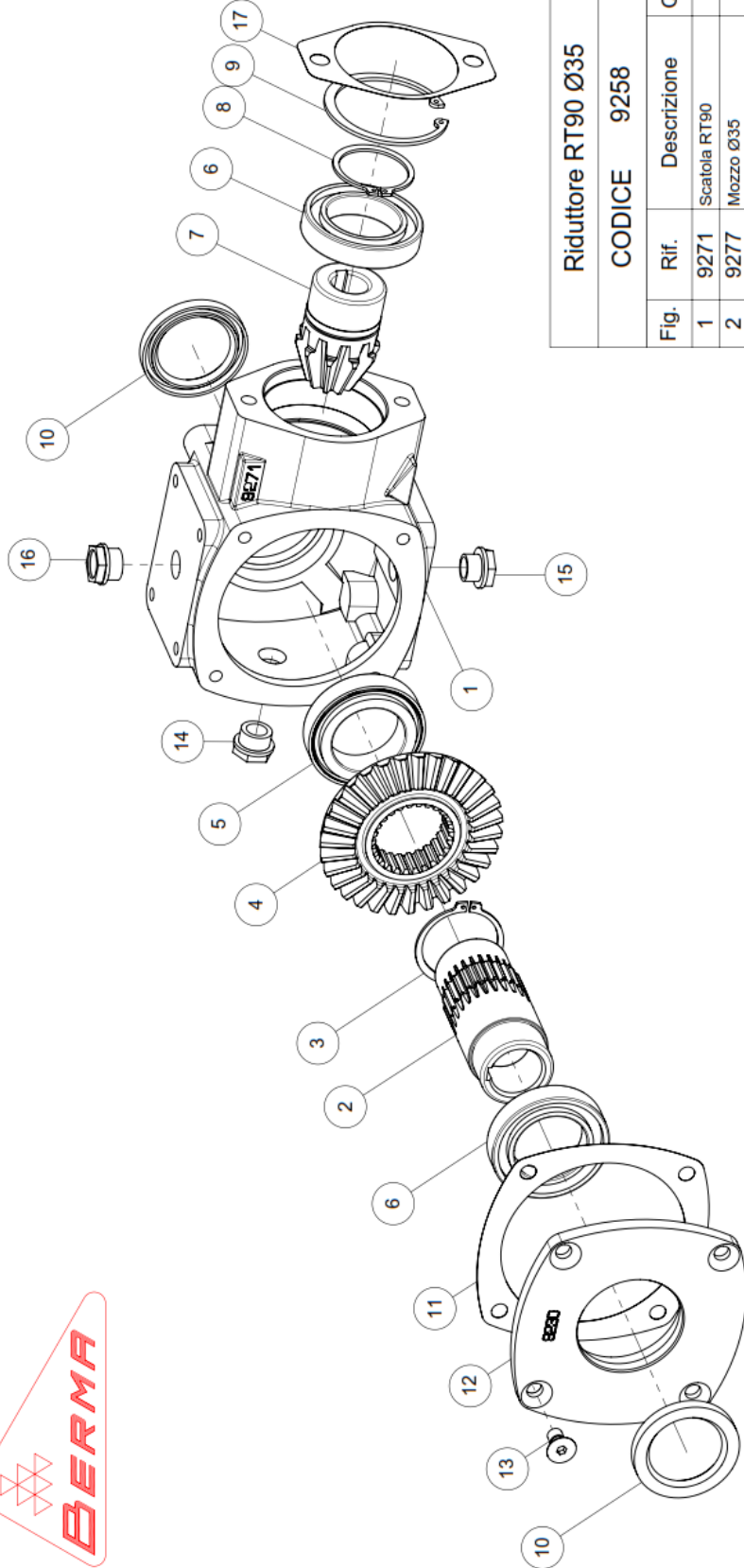

Riduttore RT90 Ø35

CODICE 9258

Fig.	Rif.	Descrizione	Qt.
1	9271	Scatola RT90	1
2	9277	Mozzo Ø35	1
3	3430	Seeger E 55	1
4	9256	Corona Z=31	1
5	9279	Cuscinetto 32010X	1
6	1538	Cuscinetto 6010	2
7	9255	Pignone Z=10	1
8	3428	Seeger E 50	1
9	3435	Seeger I 80	1
10	9227	Anello di ten. 50/72/8	2
11	9229	Guarnizione coperchio	1
12	9230	Coperchio	1
13	9231	Vite TSEI M10x20-8G	4
14	1257	Spia liv. olio Ø1/2"Gas	1
15	1714	Tappo scarico Ø1/2"Gas	1
16	5689	Tappo sfiato Ø1/2"Gas	1
17	8671	Guarnizione x motore	1

RT120 Gearbox

Riduttore RT120 Ø40			
CODICE 13039			
Fig.	Rif.	Descrizione	Qt.
1	13092	Scatola RT120	1
2	13094	Mozzo Ø40	1
3	13093	Corona Z=45	1
4	3429	Seeger E 65	1
5	13109	Cuscinetto 32012	1
6	3353	Cuscinetto 6012	1
7	3438	Seeger I 95	1
8	13091	Pignone Z=11	1
9	13108	Seeger E 50x3 rinf.	2
10	10552	Cuscinetto 6010-2RS	1
11	1538	Cuscinetto 6010	1
12	3435	Seeger I 80	1
13	8889	Anello di ten. 60/85/10	1
14	3660	Anello di ten. 60/85/10	1
15	1714	Tappo scarico Ø1/2"Gas	1
16	5689	Tappo sfiato Ø1/2"Gas	1
17	8671	Guarnizione x motore	1
18	13097	Coperchio	1
19	13107	Guarnizione coperchio	1
20	1257	Spia liv. olio Ø1/2"Gas	1
21	3284	Vite TE M8x16-8G	6

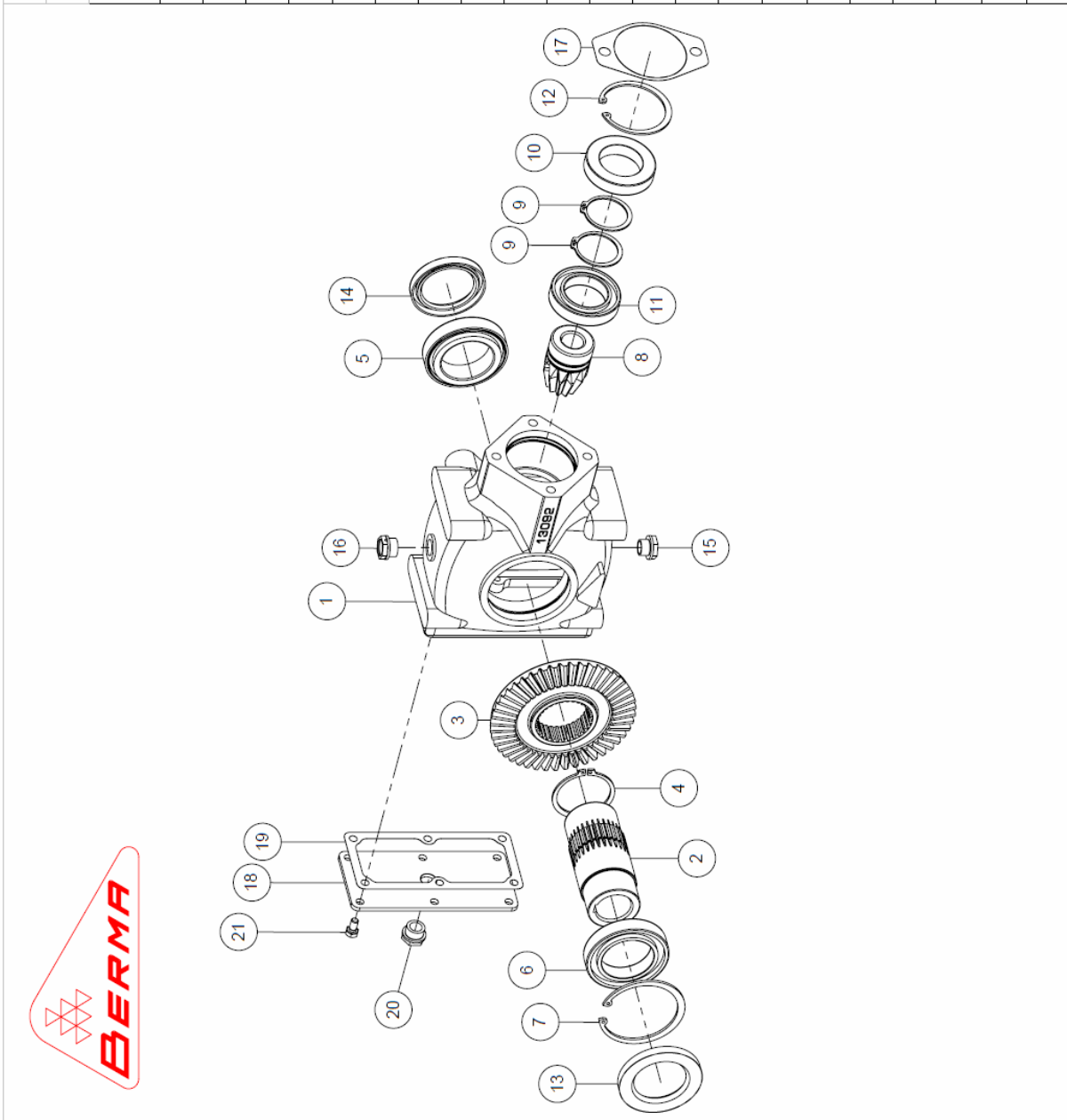

RT160 Gearbox

Riduttore RT160 Ø40		CODICE 8978	
Fig.	Rif.	Descrizione	Qt.
1	8980	Scatola RT160	1
2	8841-1	Mozzo Ø40	1
3	3429	Seeger E 65	1
4	8839-4	Ruota dentata Z=45	1
5	3353	Cuscinetto 6012	2
6	3438	Seeger I 95	2
7	8839-3	Pignone di rinvio Z=10	1
8	3397	Chiavetta 8x7x30	1
9	8984	Corona conica Z=52	1
10	8596	Cuscinetto 6305	2
11	3433	Seeger I 62	2
12	8983	Pignone Z=28	1
13	1538	Cuscinetto 6010	1
14	3428	Seeger E 50	1
15	3435	Seeger I 80	1
16	5689	Tappo sfiato Ø1/2"Gas	1
17	1257	Spia liv. olio Ø1/2"Gas	1
18	8625	Tappo Ø62 sp.10	2
19	8889	Anello di ten. 60/95/10	2
20	8842-1	Guarnizione coperchio	1
21	8842	Coperchio	1
22	3284	Vite TE M8x16-8G	6
23	8671	Guarnizione x motore	1

RT200 Gearbox

Riduttore RT200 Ø45			
CODICE 9358			
Fig.	Rif.	Descrizione	Qt.
1	9360	Scatola RT200	1
2	8670-8	Mozzo Ø45	1
3	9347	Ruota dentata Z=53	1
4	8703	Seeger E 72	1
5	8702	Cuscinetto 6013	2
6	3439	Seeger I 100	2
7	9346	Pignone di rinvio Z=10	1
8	9359	Corona Z=31	1
9	3401	Chiavetta 10x8x25	2
10	3333	Cuscinetto 6207	1
11	3435	Seeger I 80	2
12	3434	Seeger I 72	1
13	3339	Cuscinetto 6307	1
14	9255	Pignone Z=10	1
15	1538	Cuscinetto 6010	1
16	3428	Seeger E 50	1
17	8701	Anello di ten. 65/100/10	2
18	8243	Tappo Ø80 sp.10	1
19	8490	Tappo Ø72 sp.10	1
20	1257	Spia liv. olio Ø11/2"Gas	1
21	5689	Tappo sfiato Ø1/2"Gas	1
22	8671	Guarnizione x motore	1
23	9361	Guarnizione coperchio	1
24	9362	Coperchio	1
25	3284	Vite TE M8x16-8G	6

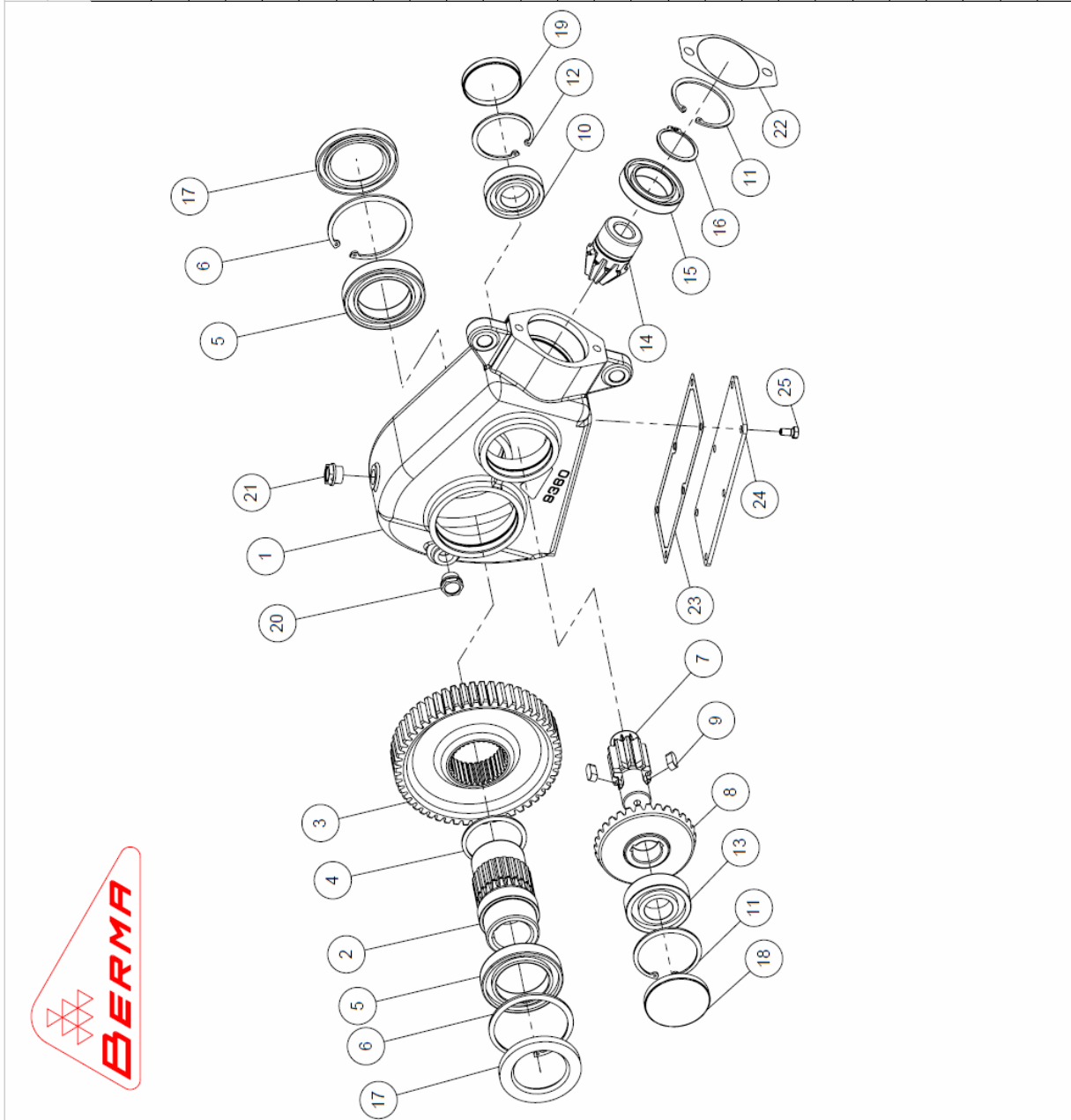

Load Weigh System

Loadcells

Wagon	Part number	Quantity
SD83/100	ES-DG8700/54	3
SD130/160	ES-DG22000/73	3
SD200	ES-DG8700/54	6

Scale towing eyes

Wagon	Part number
SD83/100	780-2012-54
SD130/160	780-2012
Jack Sleeve	780-2013

Load Weight System Components

Component description	Part number
Monitor to battery box cable	ES-PS
Monitor to junction box cable	ES-MC
Junction box to junction box cable	ES-LC
Load cell junction box	ES-JB
Load cell monitor	ES-STAD-04
Battery	TCS-Battery2

Towing Eyes

Wagon	Component description	Part Number
SD83/100	Bolt on swivel towing eye	780-2010
SD130/160	Bolt on swivel towing eye	780-2011

Hub Assembly – ADR

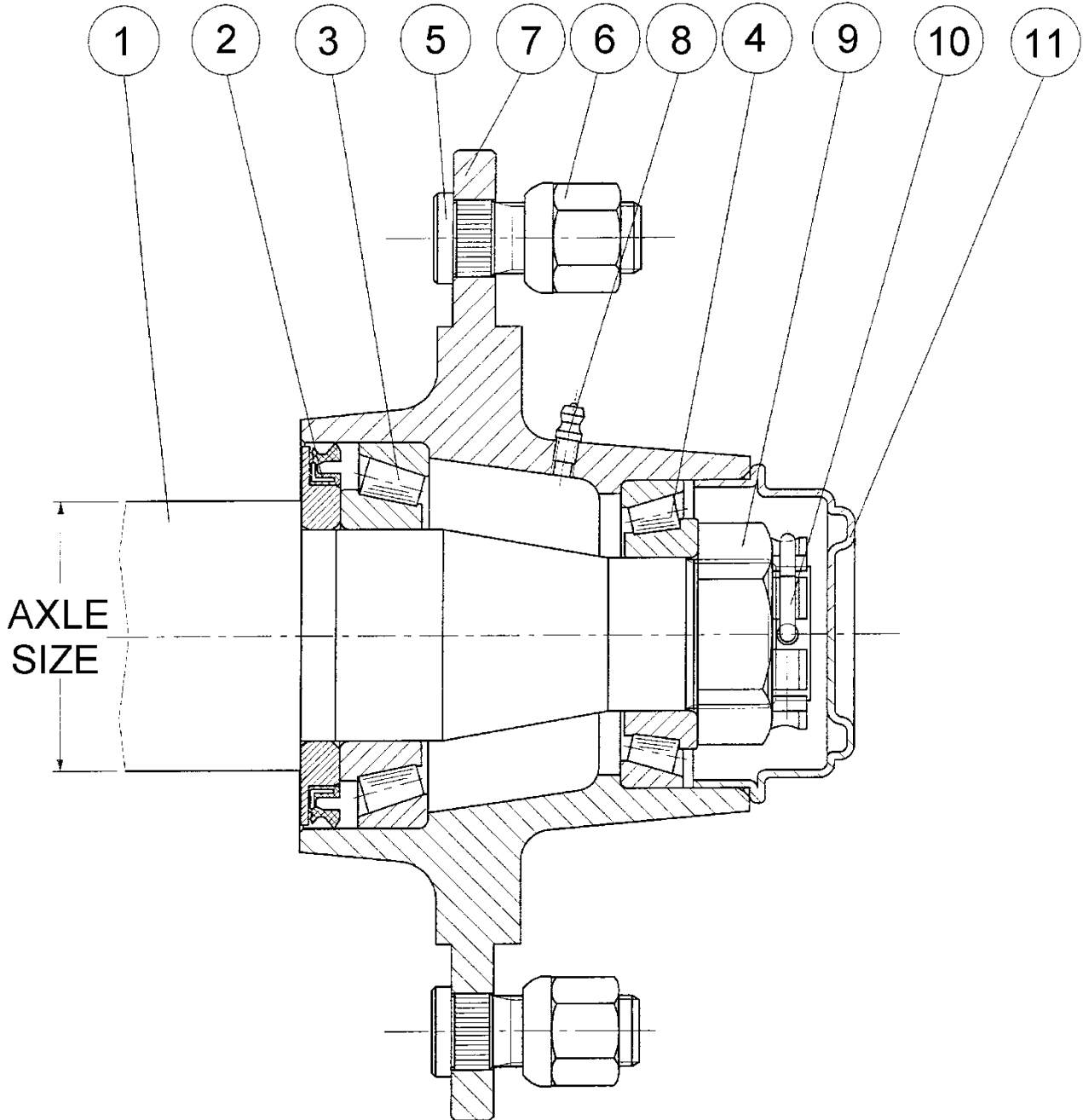

Hub Assembly – ADR

Item	Part #	Description	Quantity			
			60mm	70mm	80mm	90mm
1	HUB2000KG	Complete Stub Axle, ADR 6 stud 60sq	1			
1	HUB3000KG	Complete Stub Axle, ADR 6 stud 70sq		1		
1	HUB4250KG	Complete Stub Axle, ADR 8 stud 80sq			1	
1	HUB5000KG	Complete Stub Axle, ADR 8 stud 90sq				1
2	110-0193	Seal 57x100x10 O/A (80x100x8 nom.)	1			
2	110-0194	Seal 67x120x12 O/A (100x120x10 nom.)		1		
2	110-0195	Seal 78x130x10 O/A (108x130x8 nom.)			1	
2	110-0196	Seal 82x140x10 O/A (119x140x8 nom.)				1
3	BRG30208J2	Taper Roller Bearing, 30208 J2	1			
3	BRG32210J2	Taper Roller Bearing, 32210 J2		1		
3	BRG32212J2	Taper Roller Bearing, 32212 J2			1	
3	BRG32213J2	Taper Roller Bearing, 32213 J2				1
4	BRG30211J2	Taper Roller Bearing, 30211 J2	1			
4	BRG30213J2	Taper Roller Bearing, 30213 J2		1		
4	BRG32215J2	Taper Roller Bearing, 32215 J2			1	
4	BRG32216J2	Taper Roller Bearing, 32216 J2				1
5	110-0945	Wheel Stud, M18x50	6	6	8	
5	110-0950	Wheel Stud, M20x60x1.5				8
6	110-0917	Wheel Nut, M18	6	6	8	
6	110-0919	Wheel Nut, M20x1.5				8
7	-	Hub Only	1	1	1	1
8	GRN8-45	Grease Nipple, M8x1.0 45 deg	1	1	1	1
9	110-1047	Slotted Nut, M39x1.5	1	1		
9	110-1060	Slotted Washer Nut, M48x1.5			1	1
10	-	Retaining Clip (or Split Pin SP5x70)	1			
10	-	Retaining Clip (or Split Pin SP5x70)		1		
10	-	Retaining Clip (or Split Pin SP5x80)			1	
10	-	Retaining Clip (or Split Pin SP5x90)				1
11	110-0799	Grease Cap ADR Pressed Steel - 80mm	1			
11	110-0881	Grease Cap ADR Pressed Steel - 90mm		1		
11	110-0883	Grease Cap ADR Pressed Steel - 110mm			1	
11	110-0884	Grease Cap ADR Pressed Steel - 120mm				1

Panels

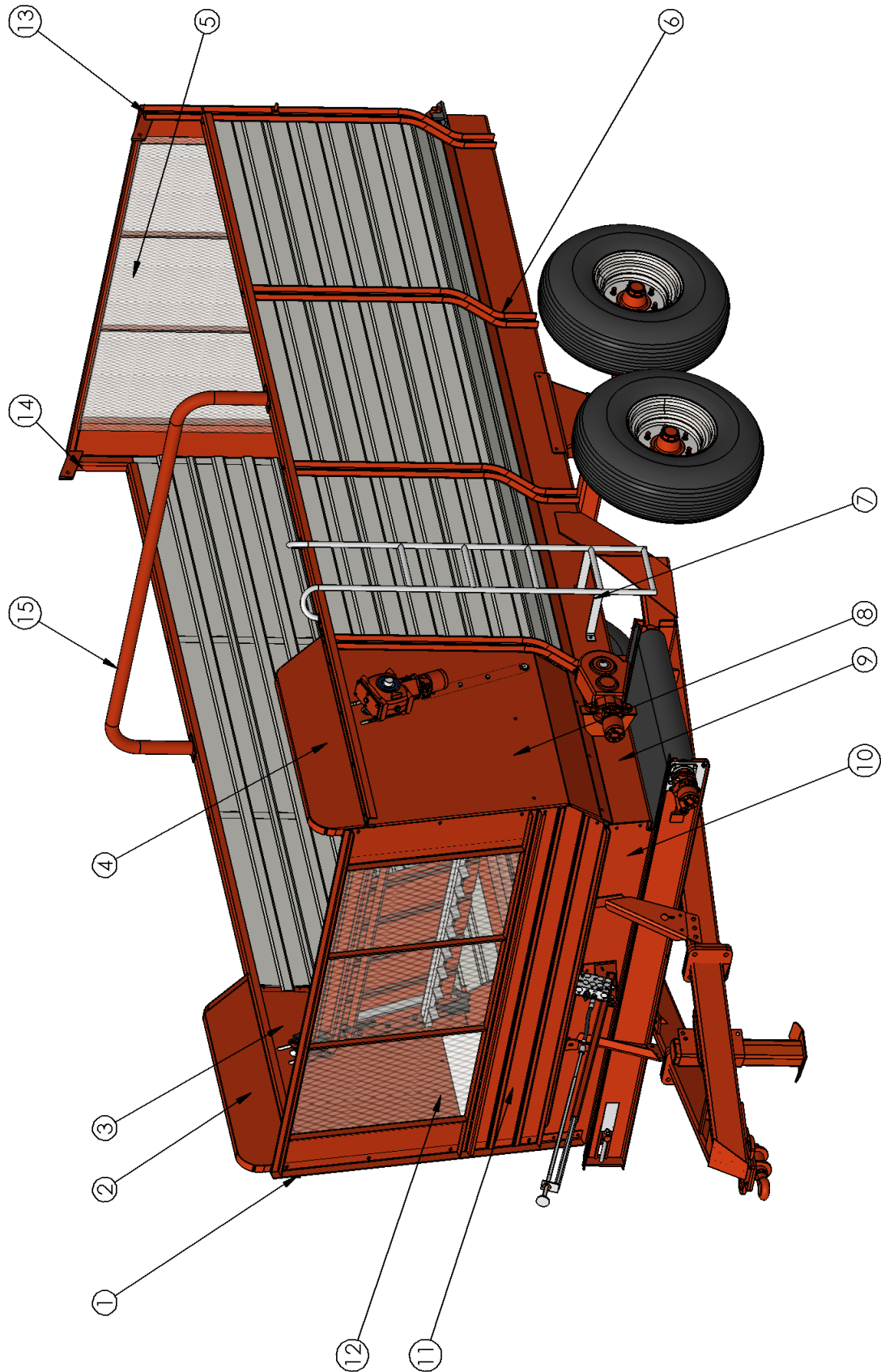

Panels

ITEM	PART NUMBER	DESCRIPTION	Qty SD83	Qty SD100	Qty SD130	Qty SD160	Qty SD200
1	50127	RH Angle Beam	1	1	1	-	-
1	780-FRONT BRACE LARG	Buc front brace	-	-	-	1	1
2	780-1546	Wagon top hat panel RH	1	1	1	1	1
3	780-1509	Side front RH panel	1	1	1	-	-
3	780-1510	Side front RH panel	-	-	-	1	1
4	780-1554	Wagon top hat panel LH	1	1	1	1	1
5	780-Rear gate	Rear wagon gate	1	1	1	1	1
6	BUCP1.445	Buckton post 1.445m	6	6	8	-	-
6	BUC1.715	Buckton post 1.715m	-	-	-	10	14
7	LADDER-BUC	Ladder	1	1	1	-	-
7	LADDER BUC-LONG	Long ladder	-	-	-	1	1
8	780-1502	Side front LH panel	1	1	1	-	-
8	780-1503	Side front LH panel	-	-	-	1	1
9	50475 (On inside of wagon)	Deflector panel	1	1	1	1	1
10	50126	Lower front panel	1	1	1	1	-
10	50199	Front panel	-	-	-	-	1
11	780-1557	Mid-panel	1	1	1	-	-
11	780-1558	Mid-panel	-	-	-	1	1
12	780-Front screen	Front screen	1	1	1	1	1
13	780-2004-LH	LH rear post	1	1	1	-	-
14	780-2004-RH	RH rear post	1	1	1	-	-
15	160 Hoop	Top pipe hoop	-	-	-	1	2

- Please measure stainless side panels before ordering
- Please measure galvanised top side panel before ordering