



# Giltrap G-Series

## Operation & Parts Manual



## **Disclaimer**

While every attempt has been made to ensure that information and diagrams in this manual are correct, Giltrap Engineering Limited will not be responsible for any damage or consequential loss arising out of misinterpretation or failure to follow recommended procedures; nor will it be liable for any damage caused by or arising out of modification or misuse of its product.

For parts or service enquiries, please use the applicable contacts on the previous page.

Printed March 2026

Copyright © 2026 by Giltrap Engineering Ltd.  
Printed in New Zealand

All rights reserved. Reproduction or use, without express permission, of editorial or pictorial content, in any manner, is prohibited.

## Table of Contents

Introduction.....	5
Warranty.....	6
Serial Number Identification.....	7
General Safety.....	8
Pre-Service Guidelines & Settings.....	11
Installation .....	13
ELECTRIC CONTROL INSTALLATION (WHERE EQUIPPED).....	13
IN-CAB TOUCHSCREEN MONITOR CONNECTIONS .....	13
TRACTOR LOOM CONNECTIONS .....	14
Operation.....	15
LOADING THE WAGON .....	15
FEEDING OUT .....	15
MANUAL CONTROL OPERATION .....	15
ELECTRONIC CONTROL OPERATION.....	18
WIRELESS SCALES.....	20
WIRELESS SCALES WITH PHONE/DEVICE SCALES DISPLAY.....	22
CROSS CONVEYOR POSITION ADJUSTMENT .....	24
SIDE SHIFT OPERATION .....	24
REAR GATE OPERATION .....	25
Maintenance .....	26
FLOOR CHAIN TENSION .....	26
ELEVATOR CHAIN TENSION .....	26
CROSS CONVEYOR BELT TRACKING.....	27
Greasing and Lubrication.....	28
Technical - Electronic Control System.....	29
DISTANCE MODE – ADJUSTING PARAMETERS .....	29
SCALES ONLY DISPLAY - WEIGHT READOUT DAMPING .....	30
STANDBY TIME ADJUSTMENT .....	32
UPDATING SOFTWARE VERSION .....	33
EXPORTING SETTINGS TO USB .....	34
IMPORTING SETTINGS FROM USB.....	35
TROUBLESHOOT - ENCLOSURE CIRCUIT BOARDS IDENTIFICATION .....	36
TROUBLESHOOT - LED STATUS LIGHTS .....	37
TROUBLESHOOT - DIAGNOSTIC NOTES.....	40
TROUBLESHOOT - LOOM PLUG WIRING .....	42
Technical - Hydraulic System Troubleshoot .....	43
4045A VALVE LAYOUT – ELECTRONIC CONTROL .....	44
4045A VALVE LAYOUT – MANUAL CONTROL .....	45
Parts Section .....	48
ELECTRONIC CONTROL SYSTEM COMPONENTS .....	49

---

CHASSIS.....	51
LOAD CELL MOUNTS G-11 .....	53
LOAD CELL MOUNTS G-13 .....	54
DUMMY MOUNTS G-11.....	55
DUMMY MOUNTS G-13.....	55
RIMA JACK.....	56
FLOOR CHAIN DRIVE ASSEMBLY .....	57
FLOOR CHAIN IDLER ASSEMBLY .....	58
BELT CROSS CONVEYOR .....	59
CHAIN CROSS CONVEYOR .....	61
ELEVATOR ASSEMBLY .....	62
CONTROL ENCLOSURE COMPONENTS.....	63
GEARBOX RT120 .....	64
GEARBOX RT300 .....	65
MUDGUARDS .....	66
AXLE.....	67
HUB ASSEMBLY – ADR .....	68

---

## Introduction

Thank you for purchasing a Giltrap product. *Giltrap Engineering Ltd* has enjoyed a long-standing success with their machinery. We would like you to enjoy the benefits of owning a Giltrap too. By following the guidelines laid out in this book, you will ensure trouble free, low maintenance operating for years.

*Giltrap Engineering Ltd* is a progressive company which continually strives to satisfy your needs, so we welcome any feedback which you can provide to help us improve our products and services and to ensure that they perform to your expectations. Any constructive comments about this operator's manual are also welcome.

Your machine has been designed to perform its task efficiently and with a minimum of maintenance. This handbook provides safety guidelines, instructions, maintenance requirements and parts listings. We recommend that you read the entire handbook, before operating the machine as this will enable you to take full advantage of your new machine's considerable potential.

## Manual Evaluation

We update our operating manuals regularly. Your suggestions for improvement help us to create even more user-friendly manuals. Send your suggestions by email to [admin@giltrapag.co.nz](mailto:admin@giltrapag.co.nz)

## Delivery and Warranty

Before you begin to use your machine, please check it to make sure there is no delivery damage. If damage is evident, contact the dealer who supplied the machine so that they can make the appropriate claims.

If you have any other queries, please contact your dealer or *Giltrap Engineering Ltd* (0800 80 GILTRAP).

All Giltrap products are covered by a 24-month warranty on parts and labour, subject to normal use.

**Please fill in the details below for future reference.**

Model:
Serial No:
Delivery Date:
Dealer:

## Warranty

The Goods specified in the Price List as designed and supplied by Giltrap Engineering Ltd are warranted against faulty workmanship and defective materials for a period of 24 months from the date of purchase. In addition to the primary 24 month warranty for Giltrap products, there is a further 12 month structural warranty for the goods, against faulty workmanship and/or defective materials for structural items only. The structural warranty does not apply to electronics or component parts.

Such warranty is subject to the following conditions:

1. This warranty covers the repair or replacement of parts or machinery sold by the manufacturer and damaged as a result of the faulty workmanship or materials in such parts or machinery. It does not extend to any other loss or damage including consequential loss or damage or loss to other property or persons.
2. Without limiting the generality of paragraph 1 above, this warranty does not cover the following:
  - (a) Travel expenses.
  - (b) Damaged caused by accident, misuse or abuse.
  - (c) Damage to any goods which have been altered or modified by someone other than the manufacturer or its authorised agent.
  - (d) Damage or loss to the goods due to their unsuitability for any particular use or for using with any particular tractor except where such use or tractor had been specifically approved by the manufacturer.
  - (e) Damage or loss where the fitting and installation of the goods were not carried out by the manufacturer or its authorised dealer.
3. Procedure for recovery under warranty.  
No loss or damage will be covered by this warranty unless the loss or damage is reported immediately to the dealer (who will contact the distributor who will advise whether it is covered by the warranty and undertake the necessary action).

No warranty repair work is to be undertaken prior to an order number being obtained.

This warranty shall be interpreted according to the laws of New Zealand and the parties agree to submit to the jurisdiction of the Courts of New Zealand.

### Warranty Claims

If you wish to make a claim under warranty:

- Immediately stop using the machine.
- List details of the machine and damaged item including serial numbers and date of purchase.
- Consult with your Giltrap dealer (supplier) and have him forward your claim and the damaged item to Giltrap Engineering Ltd.

No warranty to be undertaken unless an order number is obtained from the Seller (Giltrap Engineering Ltd) prior to any work being done.

---

## Serial Number Identification

Before ordering any parts, check the serial number and the delivery date of the machine and include this information with all orders.

If the Serial Number Plate is missing, the serial number will be stamped on the front of the drawbar.



Tel +64 7 873 4199  
www.giltrapag.co.nz  
7 Main North Road  
Otorohanga  
New Zealand

DRAWBAR VERTICAL RATING (kg):

GROSS LADEN MASS (kg):

SERIAL No:

MODEL No:

This plate is provided in compliance with the NZ Land Transport Heavy Vehicles 2004 rule, section 4.2. It is the operator's responsibility to ensure that this unit is fully compliant with all current legislation when it is used on public roads. **Removal of this plate invalidates certificate.**

Serial number stamped  
onto chassis here



Tel +64 7 873 4199  
www.giltrapag.co.nz  
7 Main North Road  
Otorohanga  
New Zealand

DRAWBAR VERTICAL RATING (kg):

GROSS LADEN MASS (kg):

SERIAL No:

MODEL No:

This plate is provided in compliance with the NZ Land Transport Heavy Vehicles 2004 rule, section 4.2. It is the operator's responsibility to ensure that this unit is fully compliant with all current legislation when it is used on public roads. **Removal of this plate invalidates certificate.**

## General Safety

For the safety of others and yourself, please read and follow the precautions in this operator's manual. Pay particular attention to the following safety aspects of operating machinery.

Do not ride on or allow passengers on the machine.



Always use a recognised hitch pin with a safety clip to hook trailed implements on behind the tractor.

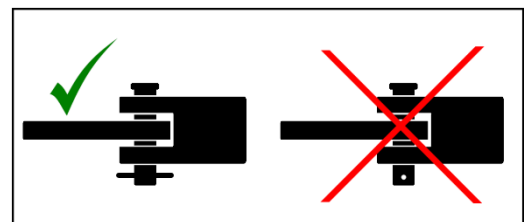

Always ensure when using a quick hitch that the locking tab has come out and is in the locked position before moving.

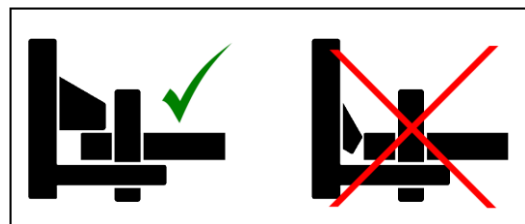

When pulling trailed implements or loads, be sure to use a tractor of greater or equal weight than the combined weight of the load and trailer.

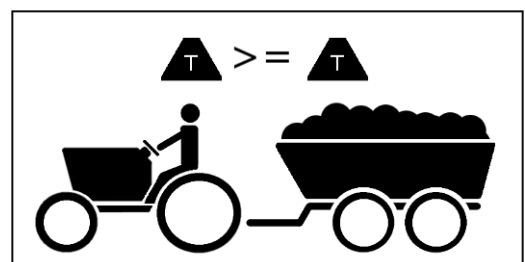

Carry a suitable fire extinguisher.

A fire can ignite under certain conditions, so please take the following precautions:

After running your machine for a short time, check for defective bearings. A faulty bearing can become very hot, eventually discolouring, requiring immediate replacement.

Do not allow combustible material to accumulate inside guards or around rollers and other moving parts.

If your machine becomes blocked, stop immediately and remove the obstruction.

Be careful when operating in hot or dry conditions or on extreme fire risk days.



Never operate your machine without the safety guards in place.



All chains should be properly adjusted and replaced when necessary.

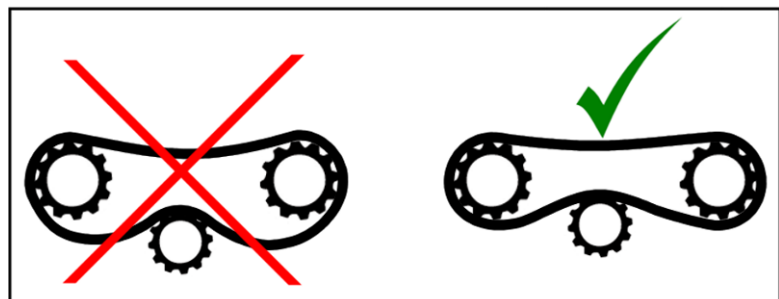

Release all hydraulic pressure from implements before commencing service work. Never look for suspected oil leaks with your hands or body - use a piece of cardboard instead. Any fluid that penetrates the skin will have to be removed immediately by a medical expert. Seek specialist advice on this type of injury.



Never attempt to unblock equipment while it is still operating. Always disengage power take-off, hydraulics and shut down engine before removing materials, checking or servicing. Failure to follow these precautions is likely to result in serious injury.



Wear proper protective clothing. Loose attire can easily be snagged by rotating machinery resulting in serious injury or death.



## Pre-Service Guidelines & Settings

Prior to delivering your machine, your dealer should have completed a pre-delivery check.

It is beneficial to check the following points before using the machine for the first time, after the first few loads, then weekly.

**CHECK FLOOR CHAIN TENSION.** A simple check is to stand in the bin and exert a strong pull at the centre of the floor. There should be approximately **75mm (3")** of vertical movement in this area.

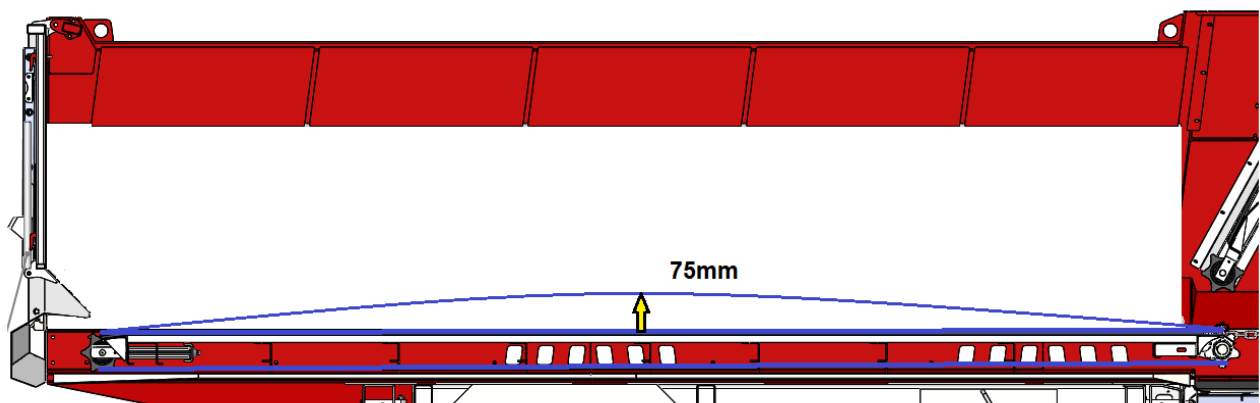

**CHECK ELEVATOR CHAIN TENSION.** Exert a pull at the mid-point of the elevator face. If necessary, adjust for approximately **35mm (1-1/2")** of movement from rest towards the rear of the wagon.

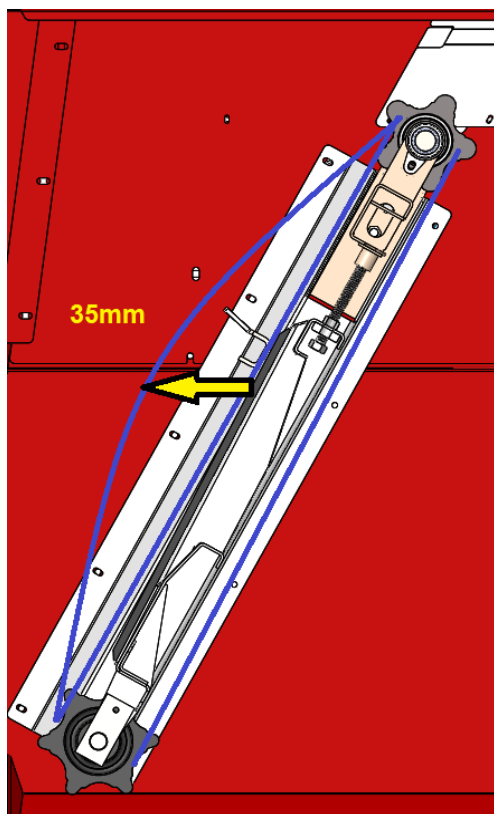

- CHECK ALL WHEEL NUTS ARE SUFFICIENTLY TIGHT.

Wheel Nut Recommended Torque Settings	
M18 Stud	200 ft/lbs or 270Nm
M20 Stud	280 ft/lbs or 380Nm
M22 Stud	330 ft/lbs or 450Nm



- CHECK ALL TYRE PRESSURES ARE CORRECT.

#### Recommended Tyre Pressures

11.5/80-15.3	58psi	4.0 bar
400/60-15.5	50psi	3.5 bar
15.0/70-18	45psi	3.1 bar
400/55-22.5	46psi	3.2 bar
500/45-22.5	35psi	2.4 bar
500/60-22.5	35psi	2.4 bar
560/45R22.5	58psi	4.0 bar
560/60R22.5	58psi	4.0 bar
650/55R26.5	58psi	4.0 bar



- CHECK ALL AXLE MOUNTING BOLTS AND NUTS ARE SUFFICIENTLY TIGHT.

Axle Mounting Bolt Recommended Torque Settings	
M16	180 ft/lbs or 245Nm
M20	355 ft/lbs or 480Nm

- THE SIDE CONVEYOR BELT should be checked for alignment and tension, and adjusted if necessary to ensure it is tracking correctly.
- THERE ARE SEVERAL GREASE POINTS on all Giltrap feeders. Check the yellow label on the side of your machine to see how many grease points there are. You should fully grease everything before running it for the first time. See greasing and lubrication section in manual.
- CHECK AND RETIGHTEN WHEEL NUTS AFTER:
  - First use
  - First laden journey
  - The first 50 hours of use and every 50 hours thereafter

## Installation

Connect drawbar to tractor.

Wind up jack handle and stow jack

Connect hydraulic hoses  
Connect brake hose (if equipped)  
Connect lights plug (if equipped)  
Connect Electric control system plug (if equipped)

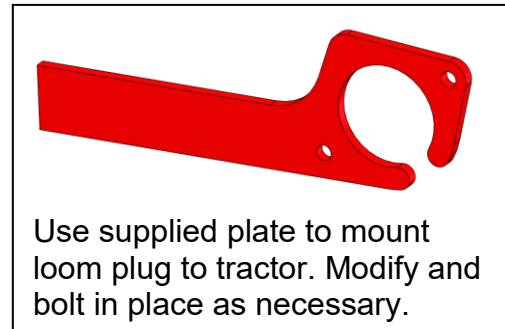

### Electric Control Installation (where equipped)

Fit monitor in cab. Power supply should be connected directly to tractor battery. It is recommended to fix the connection socket to the tractor – this will allow auto release mechanism to work.

### In-Cab Touchscreen Monitor Connections

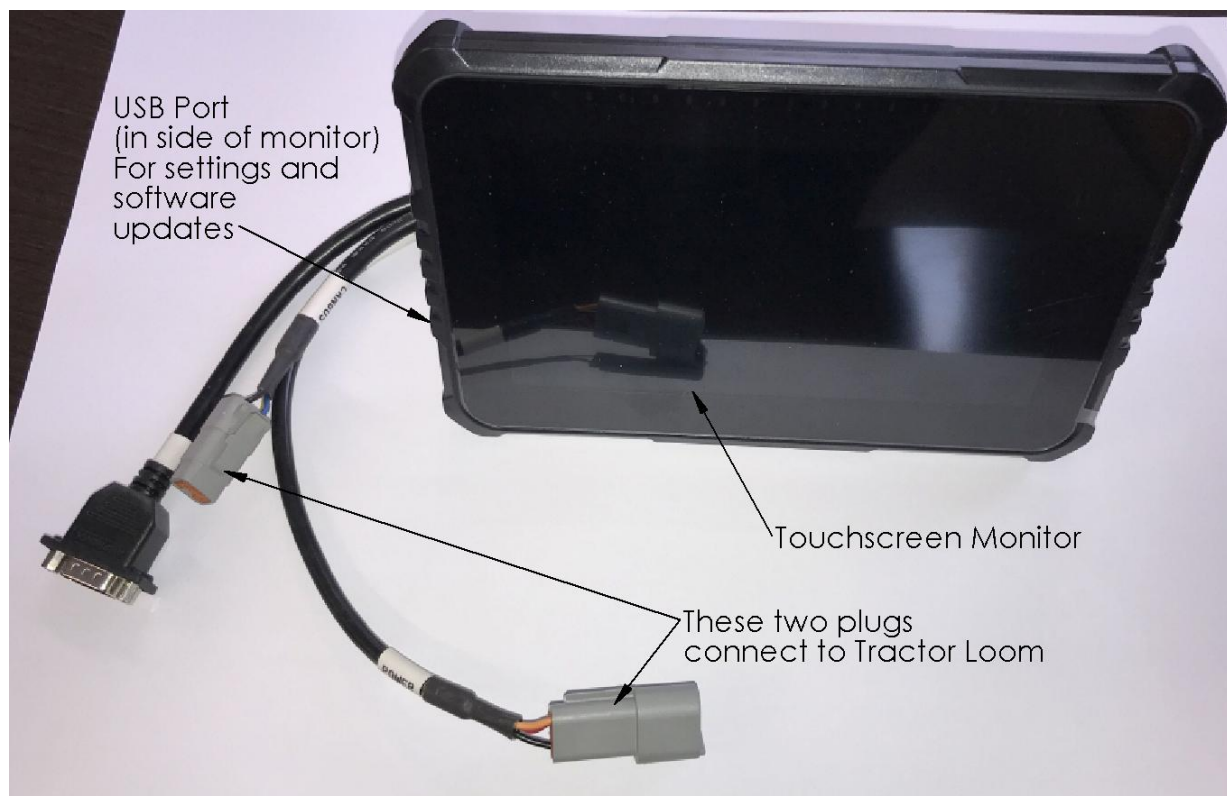

## Tractor loom Connections

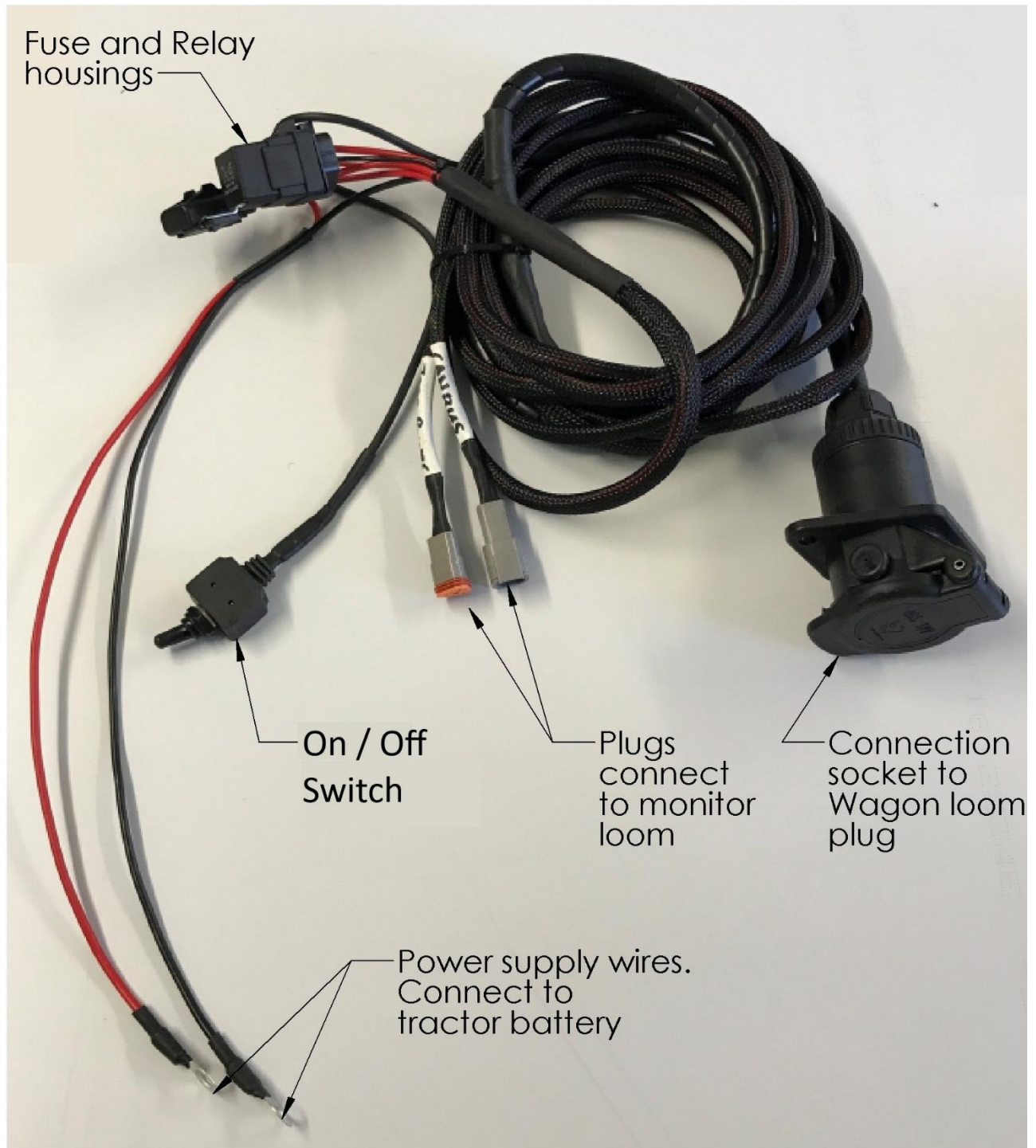

Connect Wagon loom plug to Tractor loom socket.

**Note: Wagons fitted with Phone/Device Scales display use a different Tractor loom – see ‘Wireless Scales with Phone/Device Scales Display’ section.**

## Operation

### Loading the Wagon

Load the wagon from the rear to the front. When difficult material has to be handled, eg long, wet silage, load the material in sections. It may sometimes be necessary to reverse the load a short distance and then bring it forward again to present a new face to the elevator. Note: reverse the floor by pushing the hydraulic lever on your tractor in the opposite direction.

### Feeding Out

Best feeding out conditions occur when the wagon is freshly loaded. If left loaded overnight, the material can settle into a hard mass that becomes difficult to feed out. The practice of leaving a load in the machine for hours before feeding out will also accelerate the deterioration of the wagon because of the acidic nature of the material.

### Manual Control Operation

Where electronic control is not fitted, feeding is controlled by manual adjustment of the hydraulic valve block. The hydraulic block is located under the cover at the front of the wagon.

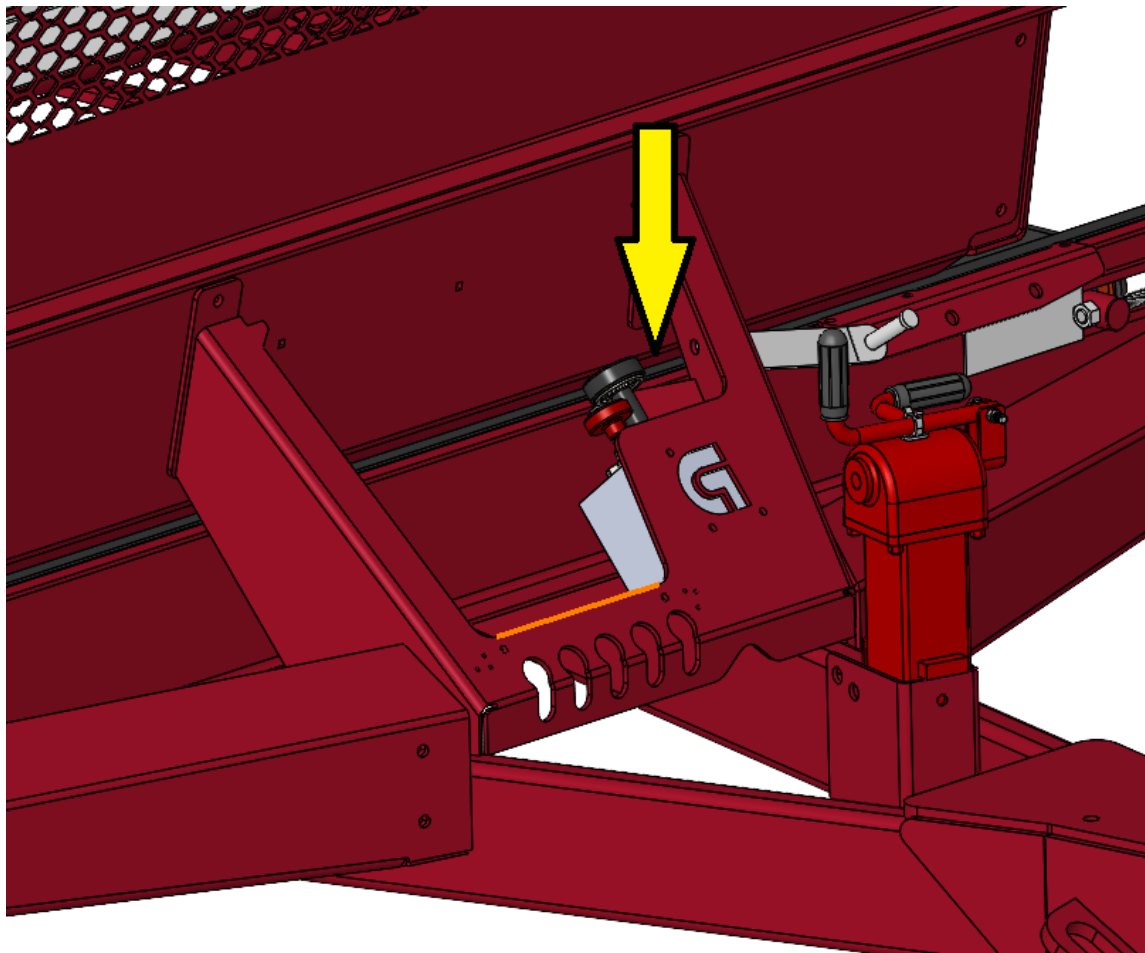

### Adjustment Knobs (Manual control):

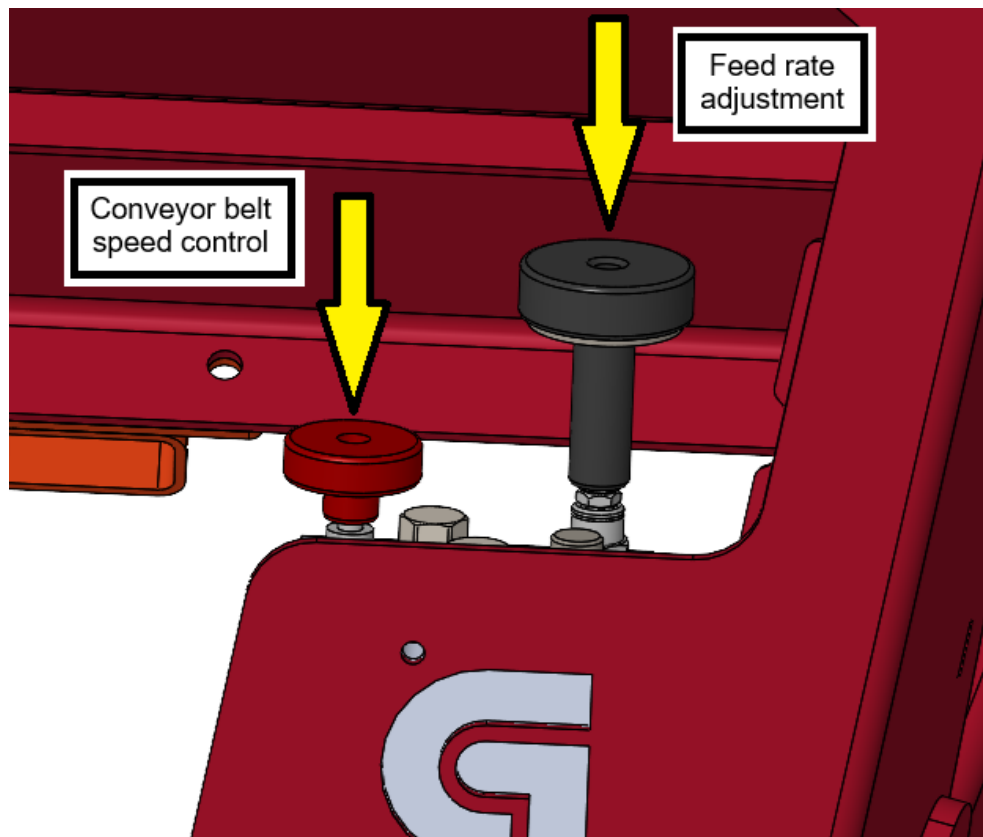

#### Conveyor Belt Speed Control

Belt speed is adjusted using the red knob shown. The conveyor belt takes priority oil flow.

Turning the valve clockwise increases the conveyor belt speed.

#### Feed-Out Rate Control

Feed Out rate is adjusted using the black knob shown. This adjusts the load pressure that the valve uses to start and stop the floor automatically. When you have adjusted the feed-out rate to your requirements, the valve will maintain an even flow of material to the elevator by automatically adjusting the floor speed. As the wagon empties the floor will automatically speed up to its maximum speed.

Turning the valve clockwise increases the feed out rate.

If the elevator chain stalls from overloading, reduce this setting.

To Feed Out, engage tractor hydraulics and drive forward. Ensure hydraulic flow is sufficient to cause the elevator to turn smoothly (30-60 litres per minute at full working pressure: 2500 - 2800psi (170 – 190 bar)).

## Manual Hydraulic Override of Electronic system

It may sometimes be necessary to over-ride the electronic control system and use the wagon in manual mode. This can be done by adjusting the control knobs on the hydraulic block.

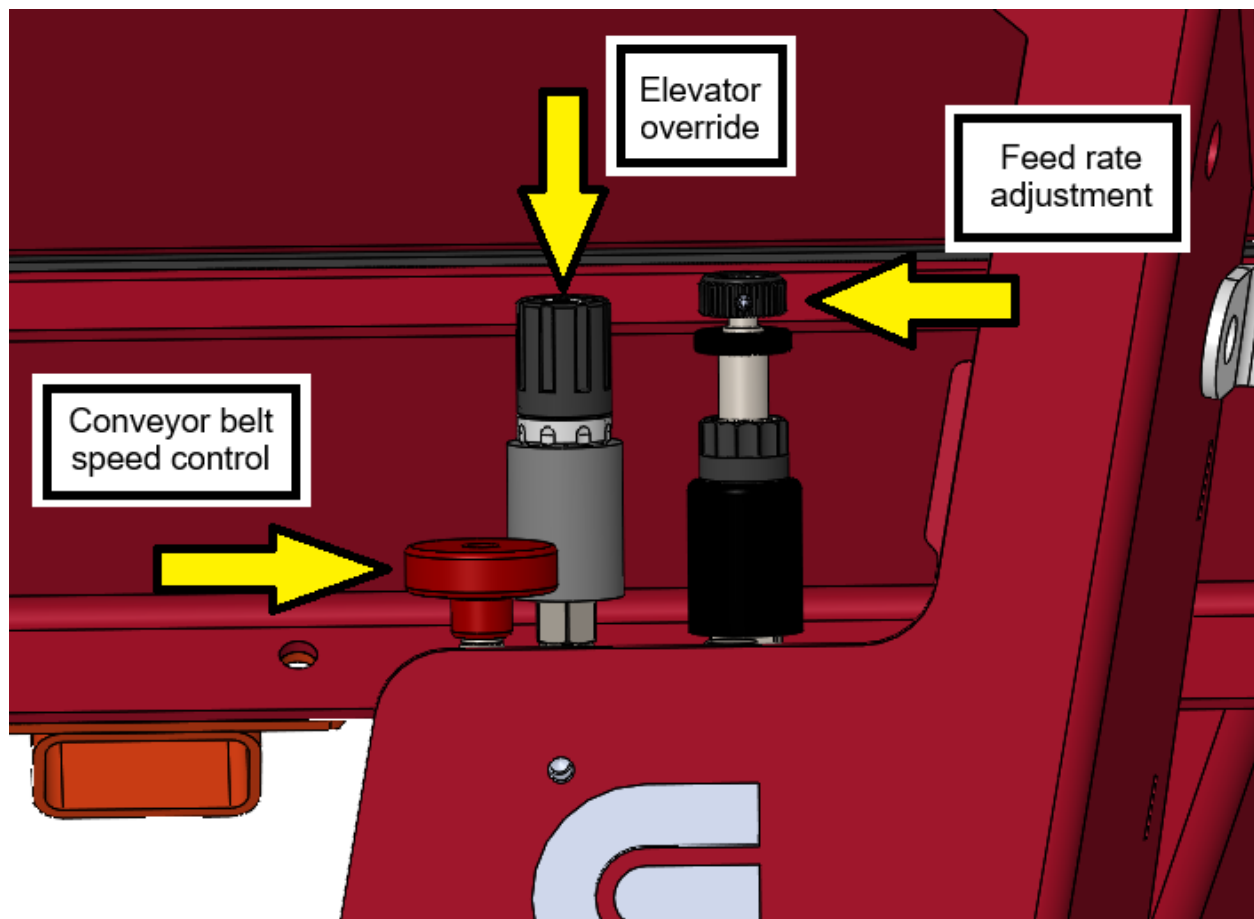

- The Conveyor belt speed control Red knob controls conveyor belt speed.
- The Elevator over-ride (centre black) knob is a 'spring to centre' type when used in electronic control mode. **To over-ride the elevator electronic control, turn this knob anti-clockwise until it 'clicks' and holds its' position.**
- The Floor over-ride black knob is a rotary adjustment type. For electronic control this knob must be turned anti-clockwise all the way out. **To over-ride electronic floor rate control, turn this knob clockwise until the floor moves when the hydraulics are engaged.** The feed rate may then be adjusted to suit by screwing the knob in (higher rate) or out (lower rate).

## Electronic Control Operation

Turn on the in-cab touchscreen monitor using the switch on the Tractor loom.  
Engage the tractor hydraulics. The Cross conveyor belt will run continuously.  
Cross conveyor belt speed is adjusted as per manual adjustments above

### Rate Control

On wagons equipped with electronic rate control, the feed rate may be adjusted from the tractor cab. Once hydraulics are engaged, feeding out is also turned on and off using the touchscreen.

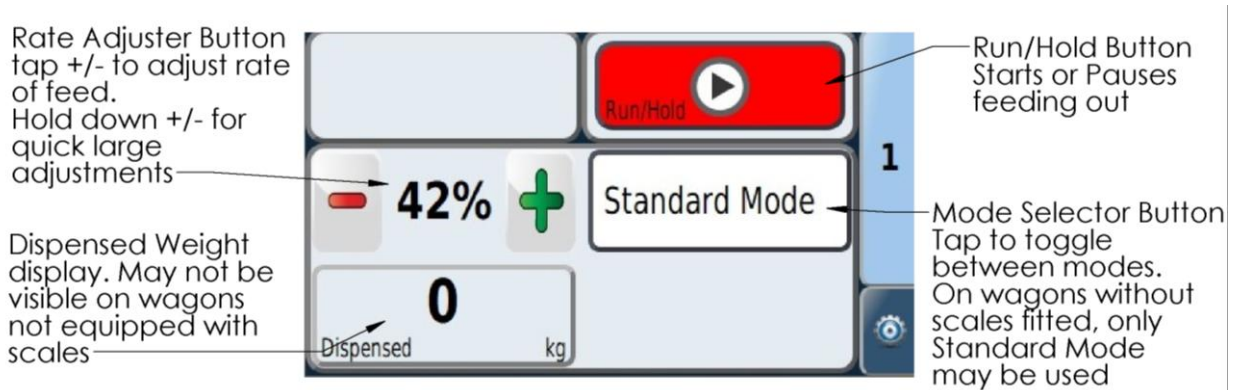

### Rate Control with Scales Fitted

#### Standard Mode

With Scales fitted, the weight of product in the wagon and the amount dispensed are displayed.

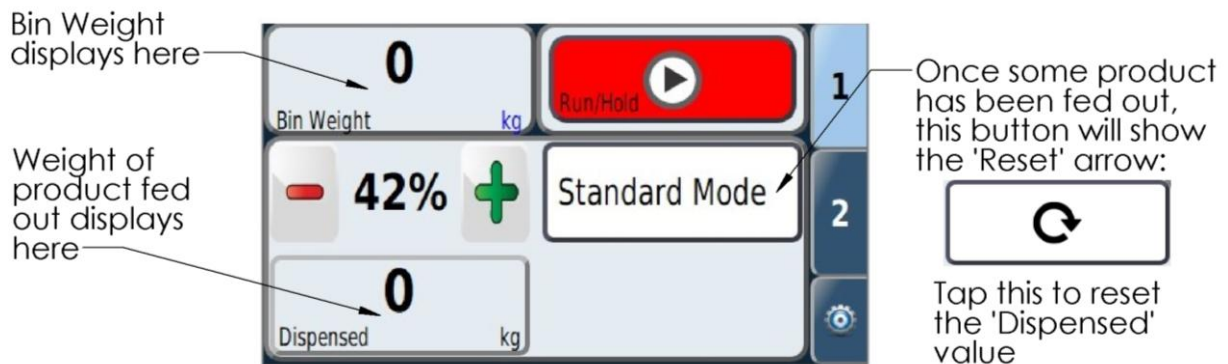

### Weight Mode

With Scales fitted, Weight mode allows a pre-set amount of feed to be dispensed before the wagon automatically stops feeding

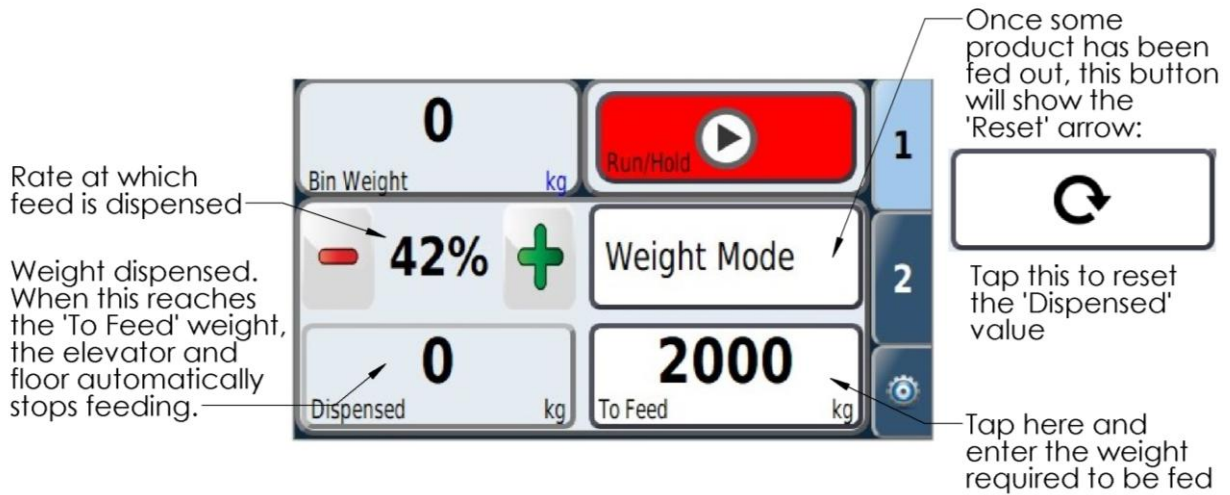

### Rate Control with Scales and Wheel Speed Sensor Fitted

#### Distance Mode

With Scales and a Wheel speed sensor fitted, Distance mode allows a pre-set amount of feed to be dispensed over a pre-set distance before the wagon automatically stops feeding. This is useful when feeding into troughs or to ensure a sufficiently long feed-row in a paddock.

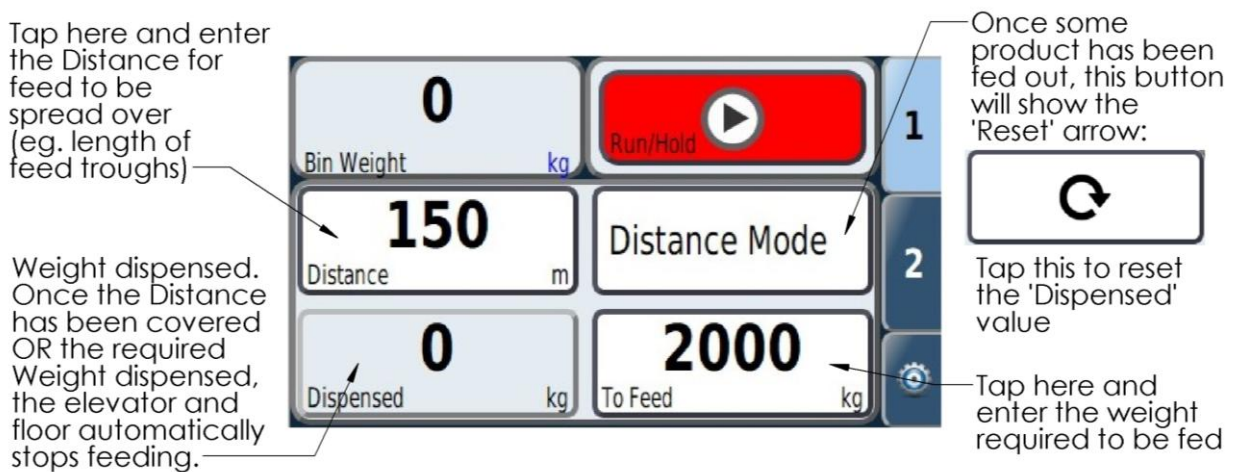

For fine tuning adjustment see 'Technical' section.

## Wireless Scales

When equipped with Load cells, the bin weight may be monitored in real time, even with the wagon disconnected from the tractor. The system uses its own built-in WiFi to communicate.

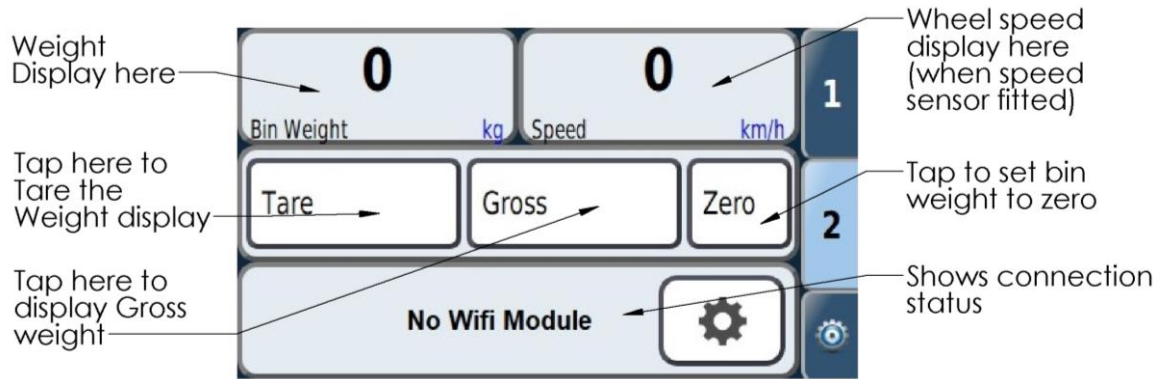

Note: when disconnected from the tractor, the system:

- cannot operate feeding controls
- cannot set bin weight to zero

Both these tasks require the electrical plug and socket to be connected. The 'Wagon Active' and green socket symbol will be displayed when the wagon is plugged in to the in-cab monitor:



When the electrical plug and socket are disconnected, the Wifi will become active for displaying weight:



The wagon may now be loaded by the towing tractor, with live bin weight readout in the cab.

NOTE: If the tractor goes out of range of the Wifi, or if the wagon control box times out and turns off, the Wifi symbol will turn Red, indicated a broken connection. To reconnect, either move the tractor closer to the wagon, or press the Standby Button on the control box.

For Weight readout damping adjustment see 'Technical' section.

### Wagon Standby Button

When the electrical plug and socket to the tractor are disconnected, the wagon control box remains on for a set length of time to allow for wireless scales display. Once time is up, the control box will turn off to conserve on-board battery power.

To turn the unit back on, either plug in the tractor electrical plug and socket, or press the 'Standby' button located above the hydraulic valve controls.

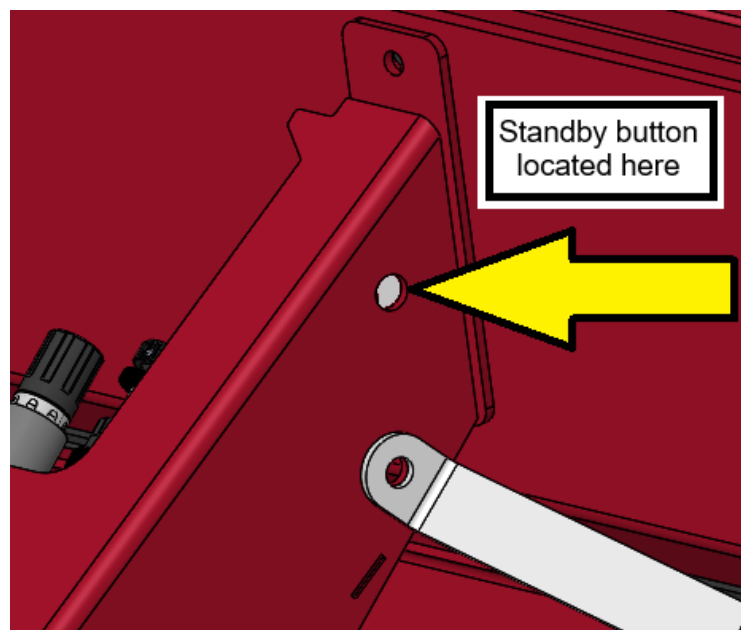

For Standby time adjustment see 'Technical' section.

**DISCONNECT OR ISOLATE WAGON BATTERY IF PARKING UP FOR MORE THAN TWO WEEKS.**

## Wireless Scales with Phone/Device Scales Display

Wagons fitted with this option use the simplified Tractor loom below:

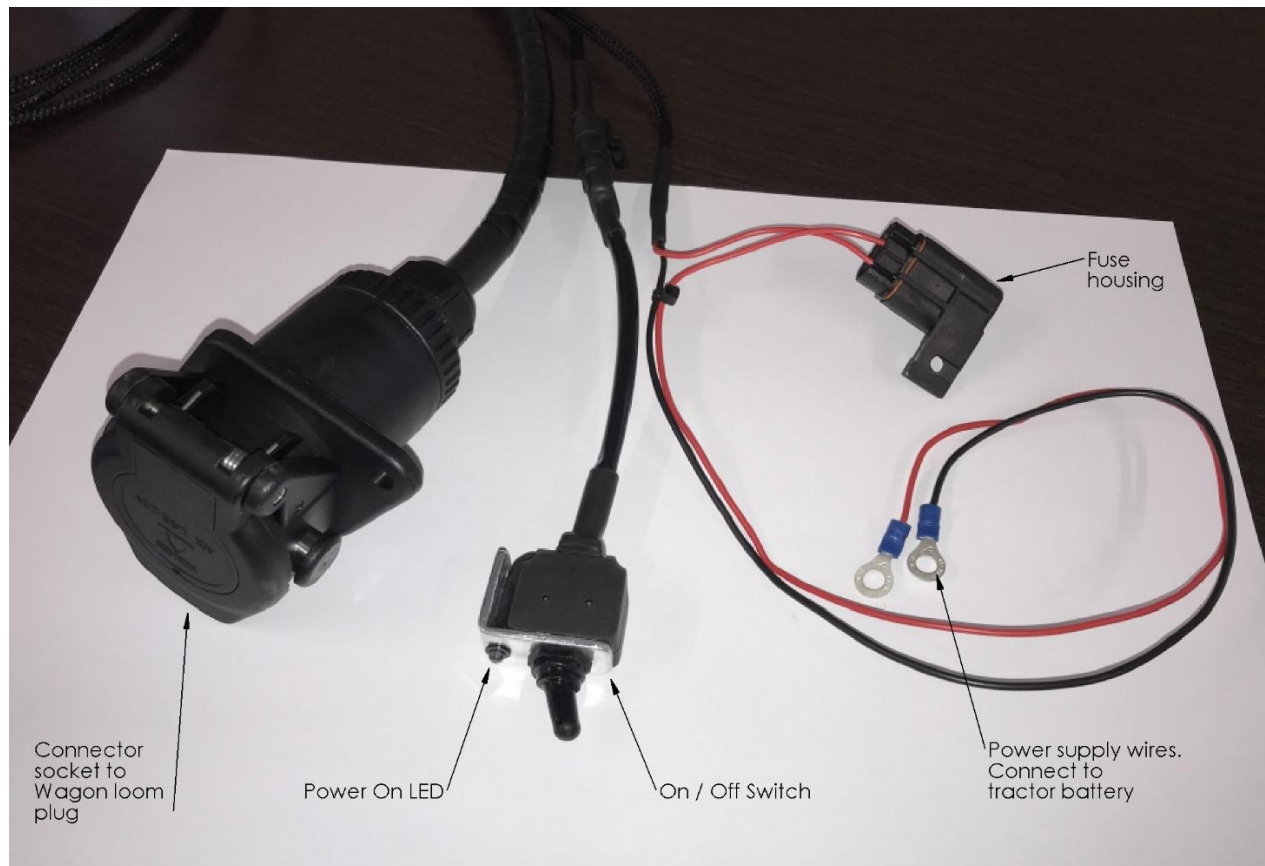

The wireless scales need to be connected to the tractor regularly to keep the on-board battery charged. The Switch needs to be turned On for charging to occur.

Most Devices capable of receiving WiFi can be used as a readout for the Wagon scales.

The Control System on the wagon needs to be turned On in order for scales to work. Either connect the tractor cable, or press the 'Standby' button on the wagon.

The QR Code giving access to the WiFi signal is displayed on the outside of the Control System enclosure under the stainless steel cover on the left side of the wagon. Follow the steps below to connect.

## Connecting your Device to Wagon Scales WiFi

1. On your device ensure your WiFi is enabled. Ensure it is not connected to any other WiFi signal.

2. Ensure both WiFi Calling and mobile data is off. (This may not be necessary in some devices).

3. LC-(unique ID code) will be visible as an available WiFi signal, connect to it. **Enter Password: 12345678**  
Disregard any warning that you are connected BUT have no internet – this is normal.



4. Select your QR reader app. Some devices may have this function built into the camera app. Hover over the QR code sticker on the Enclosure and it should bring up a URL of 192.168.4.1

5. For Android, select preferred web browser.

6. Some devices will still search for the Google site. If this is the case a new browser tab needs to be opened. In the address bar type in the following IP address: **192.168.4.1**

7. The Scales display web page will load and it should look like this:

8. Tapping Tare or Gross will change the weight display. Note this will affect all connected devices.

9. A shortcut to the display page may be added to the Devices Home screen for easy future connection.

10. Note: 'Zero Bin Weight' should only be tapped when the Wagon is empty. This function erases all previous weight data and resets the Scales display.

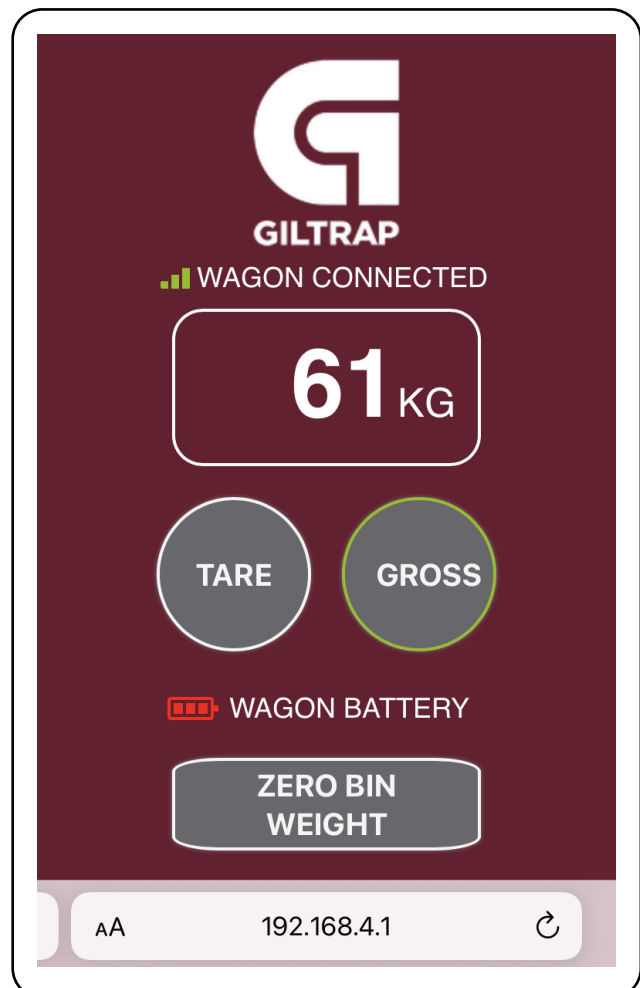

## Cross Conveyor Position Adjustment

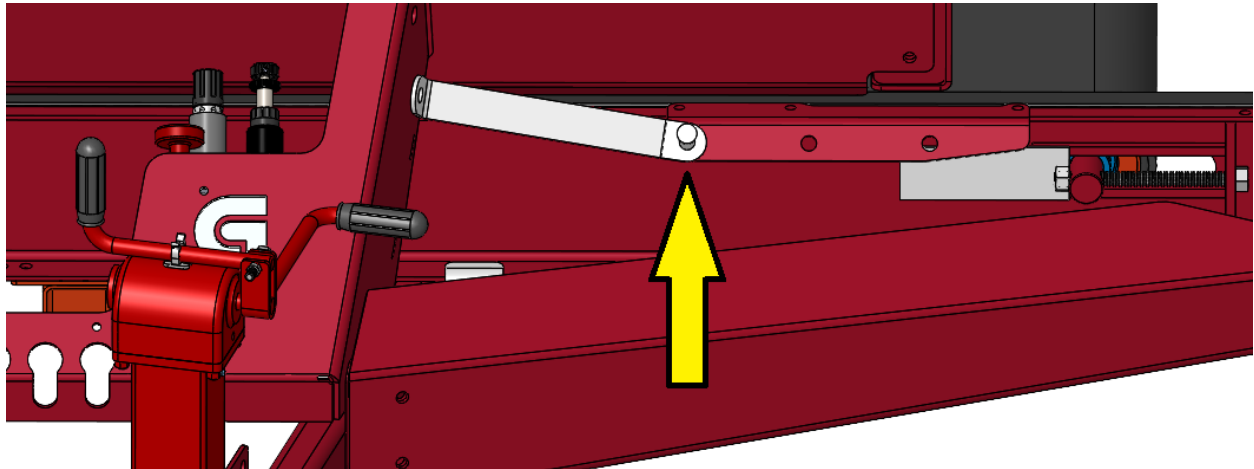

An important feature of the G-Series wagons is the ability to adjust the position of the cross conveyor assembly relative to the chassis. The cross-conveyor unit may be set to one of three positions, each giving different extension out the side.

It may be necessary to loosen the 2 clamps at the front of the machine.

Remove the retaining clip, withdraw the locating pin, slide the unit manually to suit, locate the pin in a hole, and re-fit the retaining clip underneath the locating pin.

If the optional 'side-shift' ram is fitted, bed movement can be done from the tractor seat via hydraulics.

## Side Shift Operation

The optional side shift hydraulic ram is located under the cross conveyor. Actuating it out allows 250mm of sideways extension to feed into troughs, along fence lines, etc.

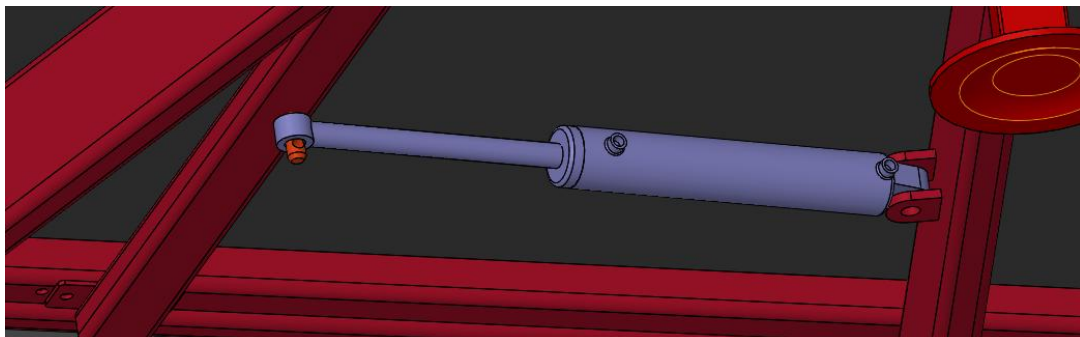

To operate, connect the two side shift hydraulic hoses to the tractor and adjust cross conveyor position using the tractor hydraulics.

Ensure cross conveyor bed is retracted before driving through narrow areas such as gateways, to avoid potential damage.

## Rear Gate Operation

The rear gate may be manually un-latched by pulling rearwards on the handle:

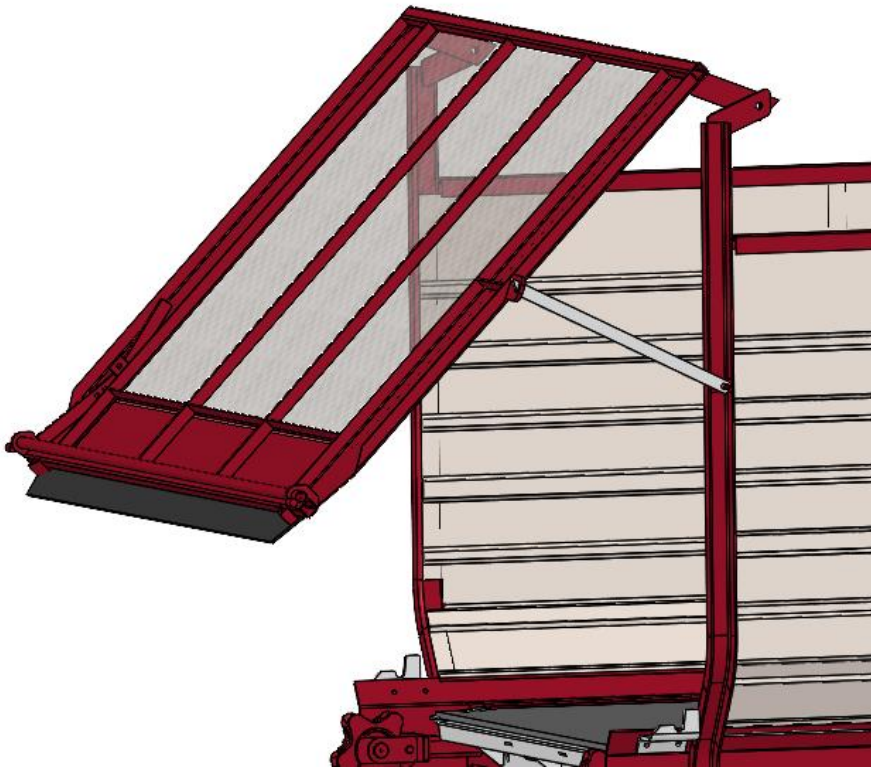
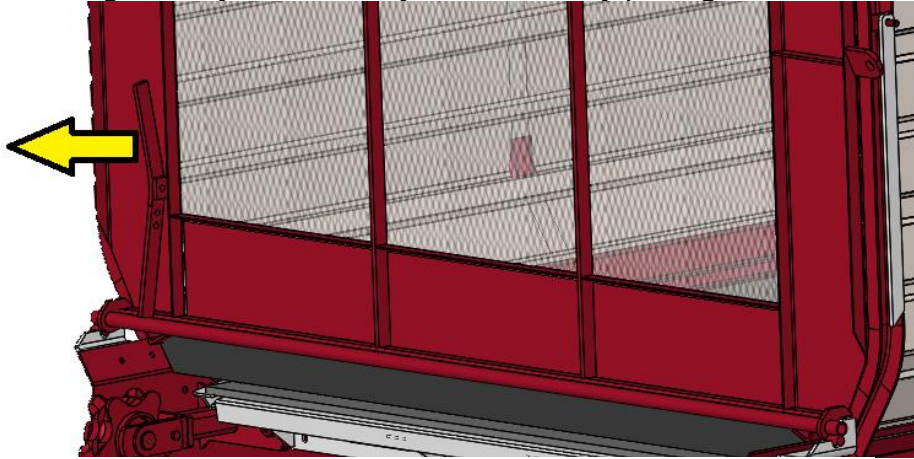

A stay is fitted which locates in the gate to hold it open for access.

Note the gate will automatically open when the main floor is reversed and product pushes against the gate. Afterwards the gate must be manually re-latched.

To re-latch the gate, hold the handle down while pushing the gate firmly against the back of the wagon. Then push the handle upwards until the spring over-centres and locks the handle in place.

**DO NOT ENTER WHEN WAGON IS IN OPERATION. IT IS RECOMMENDED THE TRACTOR IS SWITCHED OFF AND KEYS REMOVED BEFORE ENTERING THE WAGON**

## Maintenance

### Floor Chain tension

Adjust floor chain tension as per pre-service guidelines on page 11. The adjusters are located at the rear of the machine near the sprockets. Undo the locknut (where fitted) before making adjustment. Adjust both sides approximately evenly.



### Elevator Chain tension

Adjust elevator chain tension as per pre-service guidelines on page 10. The adjusters are located under the upper elevator sprockets. Undo the locknut (where fitted) before making adjustment. Adjust both sides approximately evenly.

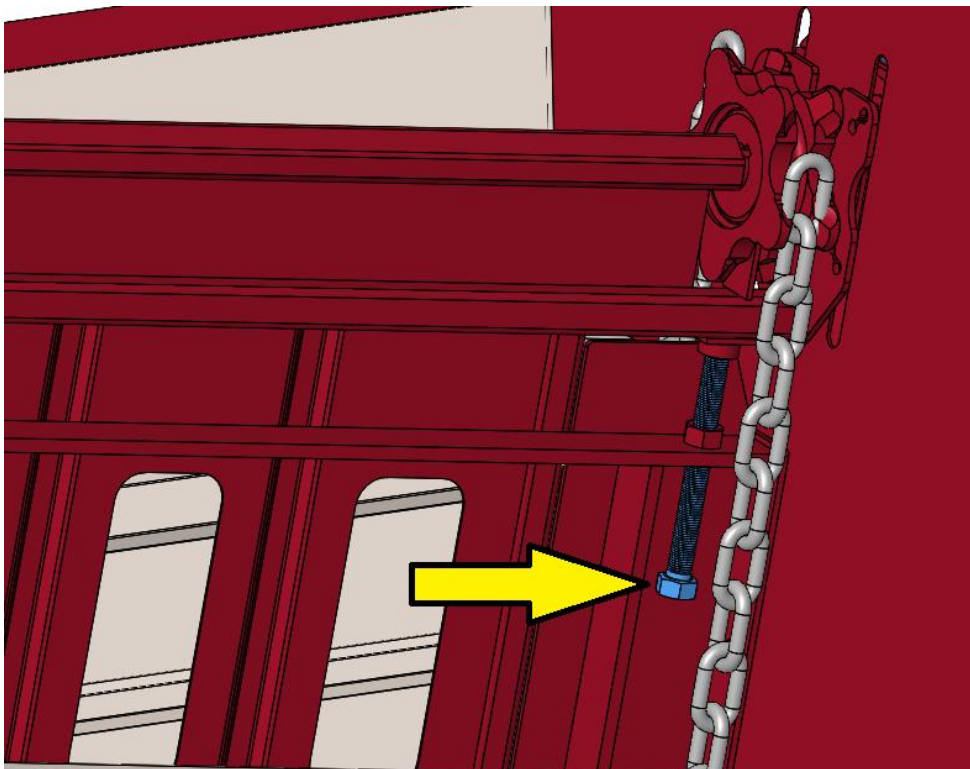

## Cross Conveyor Belt tracking

The side delivery belt is set up and adjusted at the factory before delivery, however it is usual after a period of time to notice the belt running off centre. This is normal and is caused by belt stretch or movement under load.

The adjusters are located on the left hand end of the cross conveyor unit. First, loosen the lock nut each side. Turn the bolt heads  $\frac{1}{4}$  turn at a time with the conveyor running, until the belt runs true again. You should either loosen one adjuster slightly, or tighten the other, or a combination of both. Tighten lock nuts once adjusted.

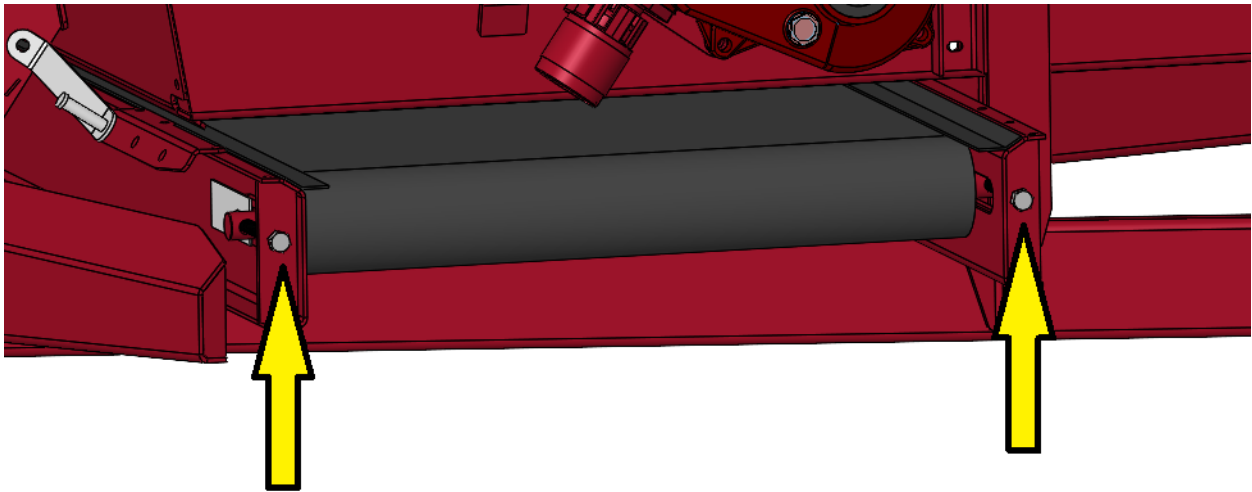

**All adjustments must be made with wagon running, preferably empty. Only adjust  $\frac{1}{4}$  of a turn at a time and run for at least 2 minutes between adjustments. THE BELT WILL RUN TO THE LOOSE SIDE.**

**DO NOT OVERTIGHTEN - THIS WILL CAUSE A POWER LOSS!**

## Greasing and Lubrication

Grease Grade Recommended: NLGI 2 oil based  
Gearbox Oil Recommended: GL-5 80w-90

**It is essential** that the bottom elevator roller sprockets and rear floor shaft sprockets are greased daily for the first week (7 days) of operation. If used initially during harvesting, requiring reversing of the floor, the rear shaft sprockets will require greasing at 3-hourly intervals. Failure to do so in the above instances will result in machine failure.

Thereafter – grease weekly during use, grease nipples located as shown below:

Lubrication Schedule	G11
Tandem axle pivot pin (both sides)	Grease every second day
Floor Idler shaft sprockets	Grease every 10 loads
Floor Drive shaft deadeyes	Grease every 10 loads
Elevator top shaft, (non-drive side)	Grease every 10 loads
Elevator idler sprockets	Grease every 10 loads
Parking jack	Grease monthly
Tow Eye	Grease monthly
Cross Conveyor Drive end bearing	Grease monthly
Wheel Hubs	Grease every 3 months
Elevator Gearbox	Maintain level as necessary
Floor Drive Gearbox	Maintain level as necessary

Elevator and floor gearbox oil levels should be checked prior to being used at the beginning of the season. Remove oil level plug, remove filler plug and add EP90 gearbox oil until excess flows out level plug hole. Replace both plugs. If oil leak is noticed at either gearbox, repairs should be carried out immediately to prevent premature gearbox failure.

At the end of the season clean wagon thoroughly and re-grease at all points. Check and/or top up gearbox oil levels and shed store.

### **POINTS TO WATCH FOR**

- **Tractor and wagon QRCs in good order and oil flow not restricted.**
- **Cross conveyor belt remains free and does not become stuck to unit body because of water and lack of use.**
- **All shafts straight and undamaged.**
- **All chains tensioned periodically if slack.**
- **Wheel bearings checked seasonally.**

## Technical - Electronic Control System

In addition to normal operation, the electronic control system features user accessible background settings, to further enhance the machines capabilities.

### Distance Mode – Adjusting Parameters

If it is found that the machine regularly over-feeds a certain weight while in Distance Mode, adjust the Early Finish Weight parameter to this weight. The machine will stop running earlier to allow for this extra output, thus increasing accuracy.

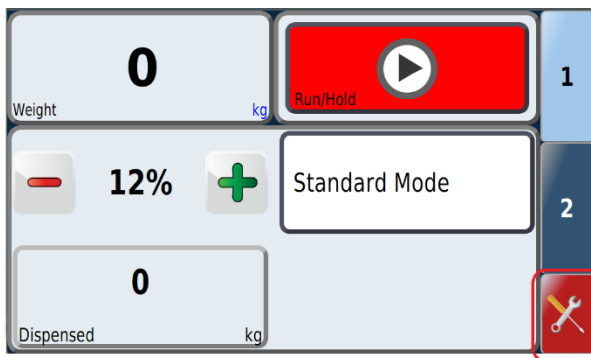

1. Tap Spanners



2. Tap Double Cog

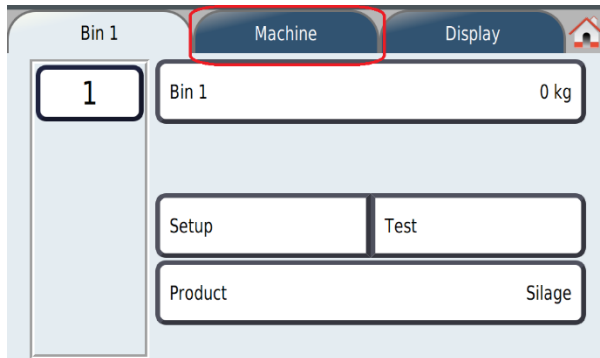

3. Tap Machine

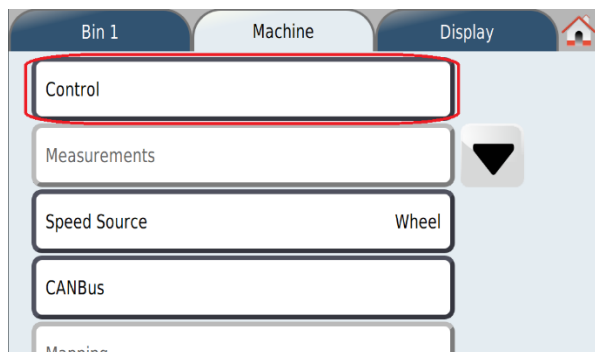

4. Tap Control

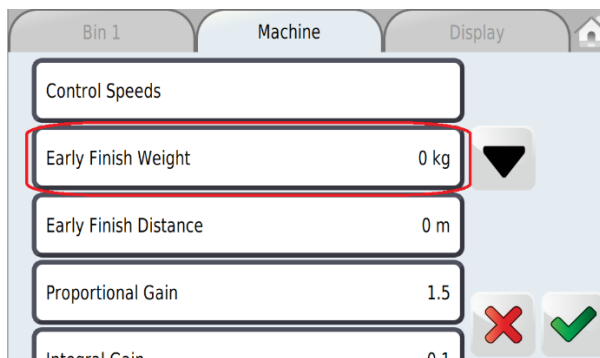

5. Tap 'Early Finish Weight'

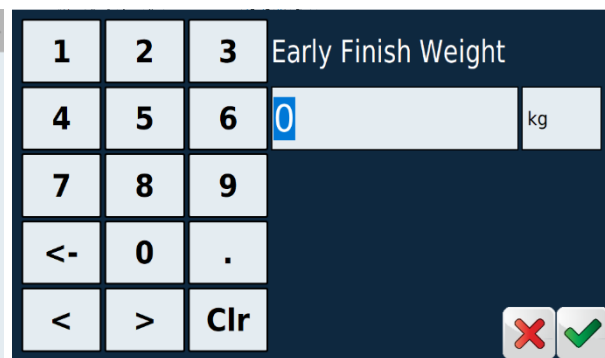

6. Enter the Weight value and tick out

If it is found that the machine regularly continues feeding past the end of the set Distance (while in Distance Mode), adjust the Early Finish Distance parameter to this distance. The machine will stop running earlier to allow for this extra length of feed, thus increasing accuracy.

Follow Steps 1-4 above then:

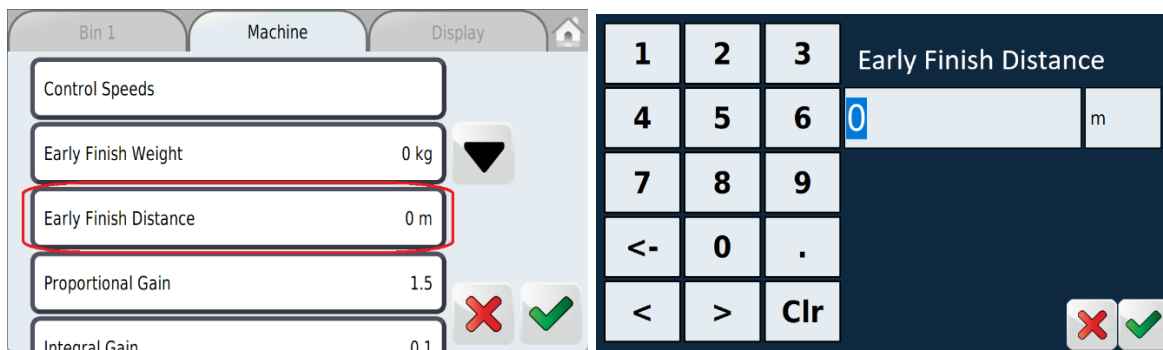

5. Tap 'Early Finish Distance'

6. Enter the Distance value and tick out

### Scales Only Display - Weight Readout Damping

If the wagon is optioned with In-cab monitor with Scales Display only, the Weight readout value may fluctuate when moving over rough ground. To adjust the readout damping:

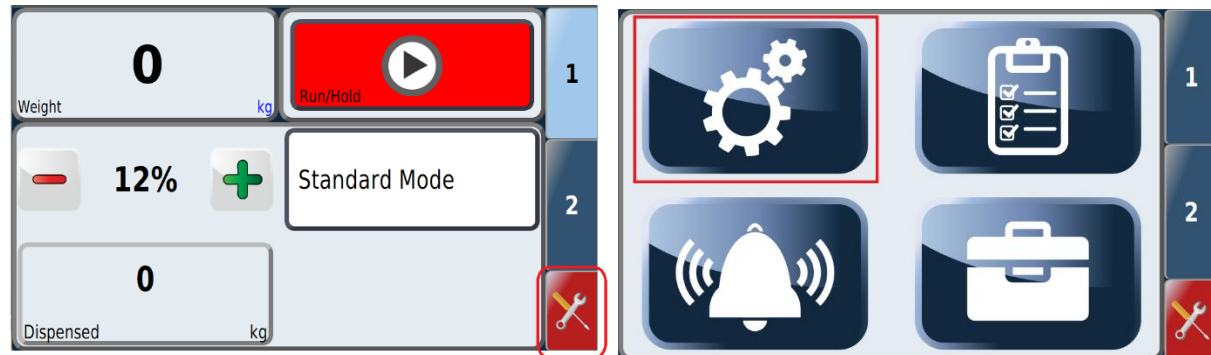

1. Tap Spanners

2. Tap Double Cog

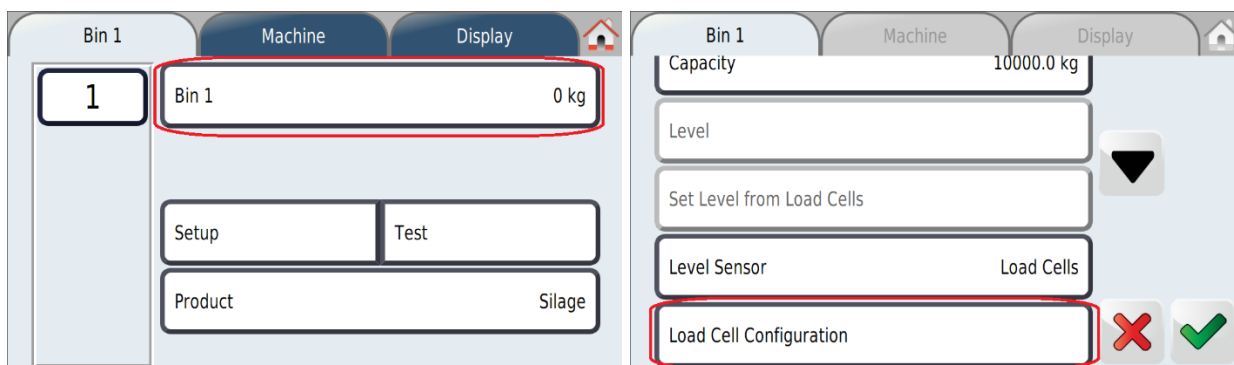

3. Tap 'Bin 1'

4. Tap 'Load Cell Configuration'

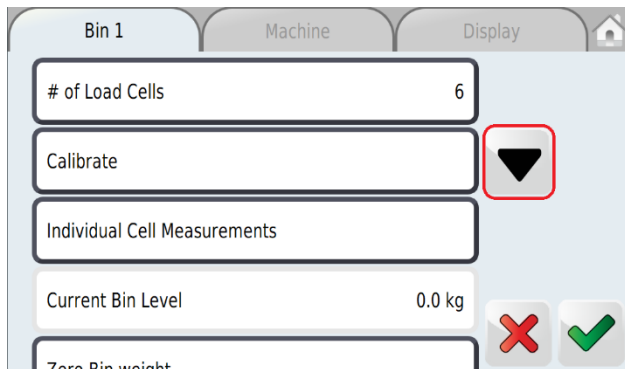

5. Scroll down

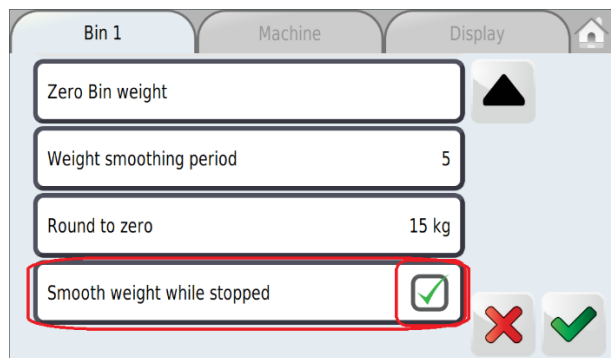

6. Tick 'Smooth weight while stopped'

- The Scales Only option has no ground speed sensor, so the control system is always considered to be 'stopped'

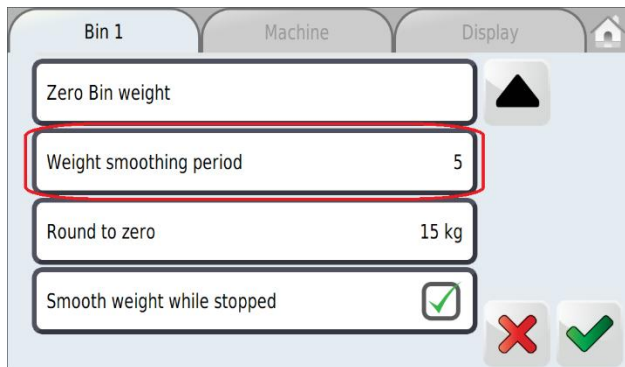

7. Adjust the 'Weight smoothing period' value

- The higher the value, the smoother the readout will be, however it will give slower response to change in weight.

## Standby Time Adjustment

When the Wagon is disconnected from the towing tractor, the scales system will remain On for a set time, to allow weight reading from WiFi connected devices. Once the set time is passed, the system will turn Off to conserve battery power. To adjust the Standby time, follow the below steps:

1. Access the Control System Enclosure at the front of the Wagon, under the plastic cover. The six Philips head fasteners require a quarter turn to release.

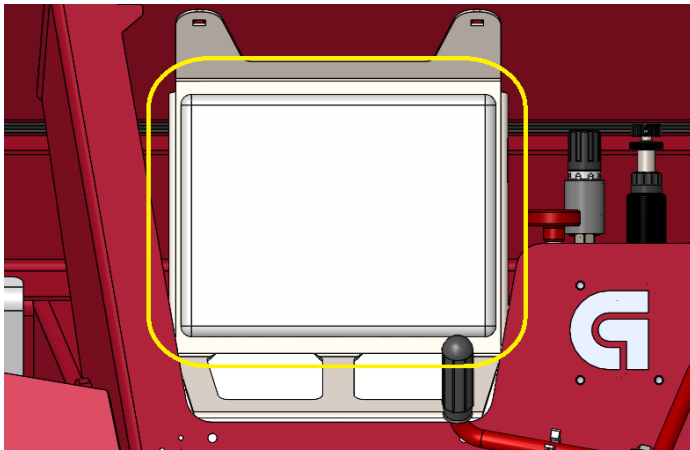

2. Locate the group of four dip switches on the Load Cell charging circuit board:

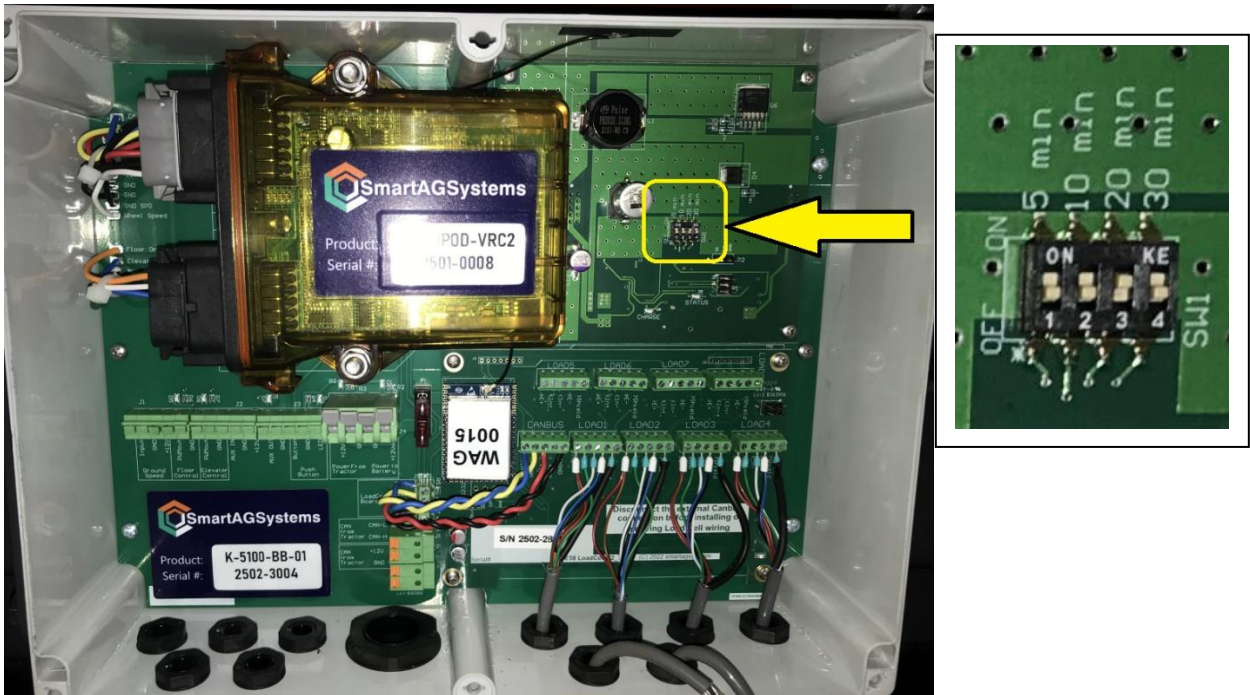

3. The Standby Time is the accumulated value of all Dip Switches in the 'Up' position – to a maximum of 1 hour 5 minutes. The Factory setting is 20 minutes.

## Updating software version

1. Tap Settings Icon

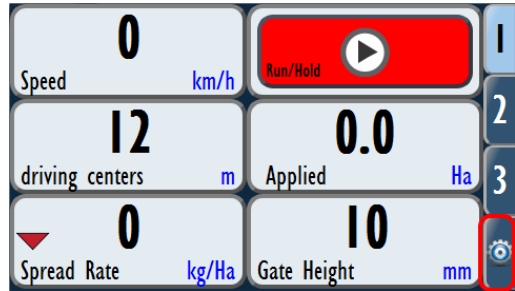

2. Tap Maintenance Menu Icon



3. Tap "System" Button



4. Insert USB with latest software into screen and press "update" button



5. Press "Begin Update" to begin. When the update reaches 100% the screen will reboot. This reboot will take longer than usual and will cause a blank green screen. Once the reboot is complete, ensure screen stays of for a few minutes.

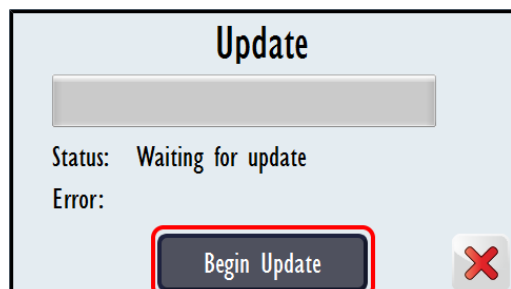

## Exporting Settings to USB

If monitor layouts and settings are customized and changed from factory defaults, they should be backed up on the supplied USB.

1. Turn on screen and insert USB to export settings onto.

2. Tap Settings Icon

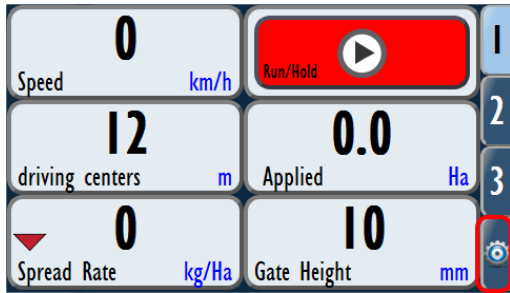

3. Tap Maintenance Menu Icon



4. Tap "System" Button



5. Tap "Reset" Button



6. Scroll Down and Tap "Export Settings to USB"

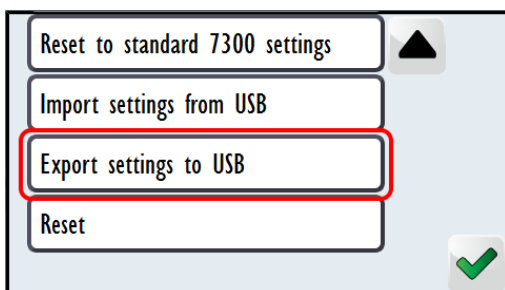

7. Tap "Ok"



This process should be done as often as settings and layouts are customized.

## Importing Settings from USB

1. Turn on screen and insert USB with appropriate .bin file.

2. Tap Settings Icon

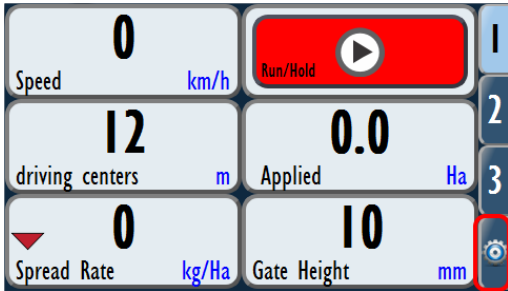

3. Tap Maintenance Menu Icon



4. Tap "System" Button



5. Tap "Reset" Button



6. Tap Import Settings from USB

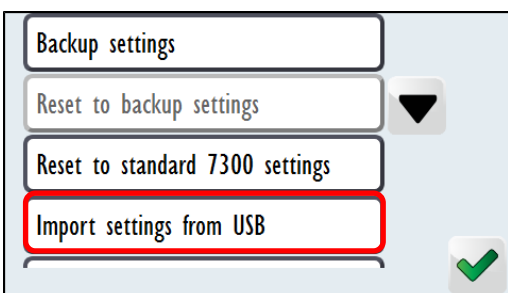

7. Tap "Ok"



8. Run machine to check upload of settings was successful.

## Troubleshoot - Enclosure Circuit Boards Identification

The Control System Enclosure is at the front of the wagon, under the plastic cover. The enclosure lid is held on with six Philips head fasteners, which require a quarter turn to release.

Which Electronic control Option determines which components are fitted.

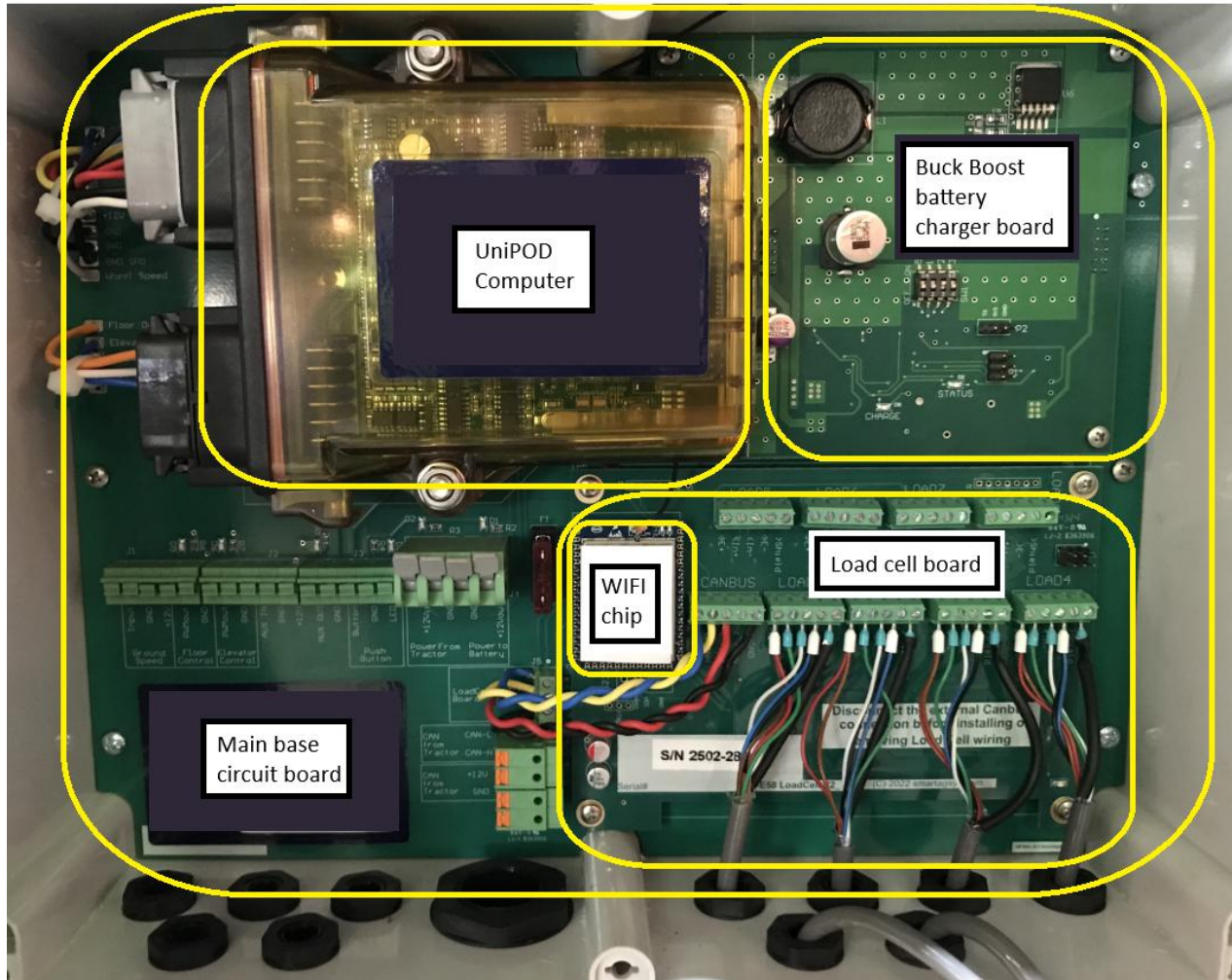

**Main base circuit board** – Fitted to all wagons with any electronic control Option

**UniPOD Computer** – Fitted whenever floor control is Optioned

**Load cell board AND Buck Boost board** – Both used when scales are fitted

**WiFi chip OR Phone Scales chip** – Either fitted depending on Scales display Option

## Troubleshoot - LED Status Lights

Each circuit board is fitted with LED lights to assist in machine function diagnostics. See diagrams below:

Main Base circuit board and Buck Boost board:

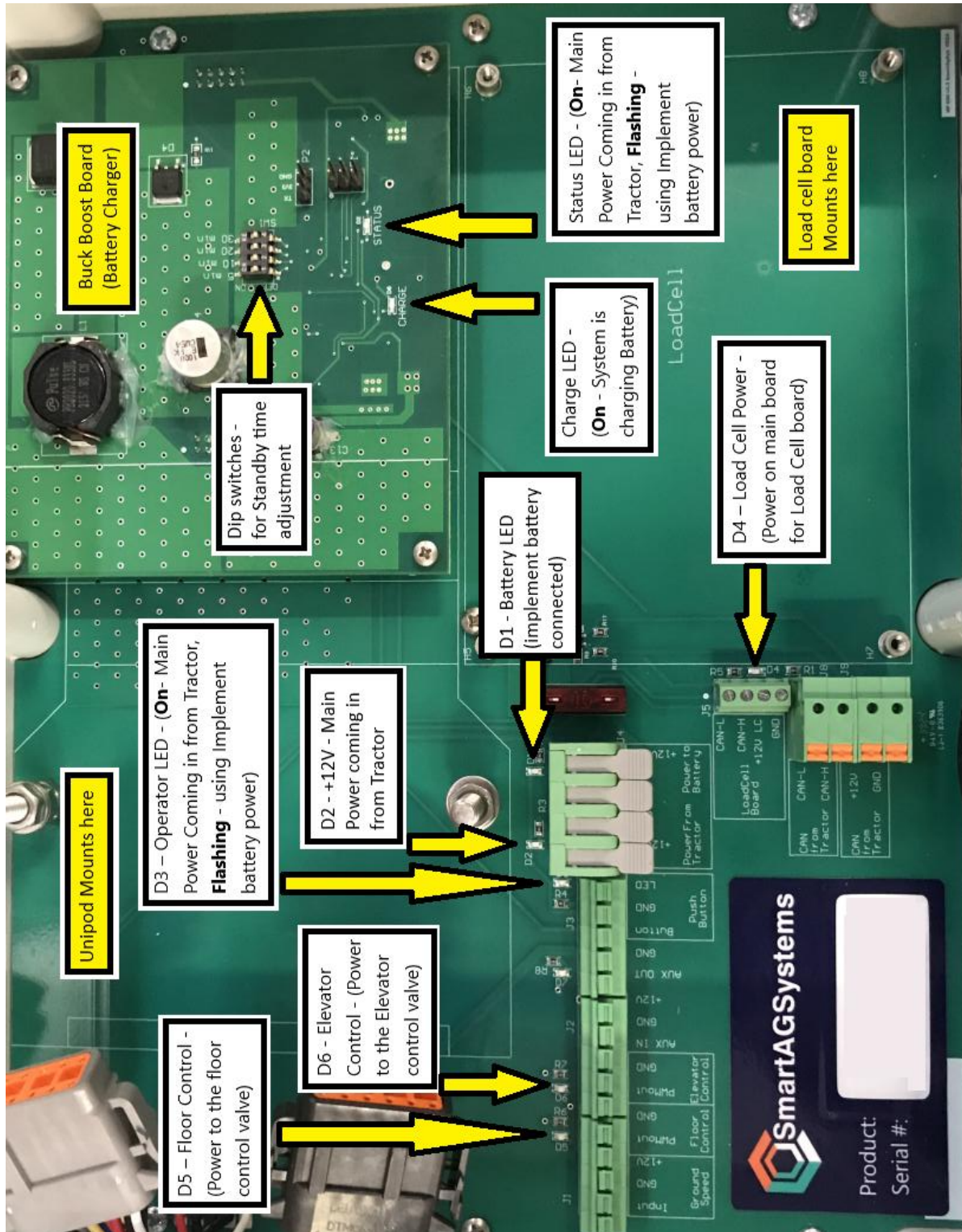

Load cell board

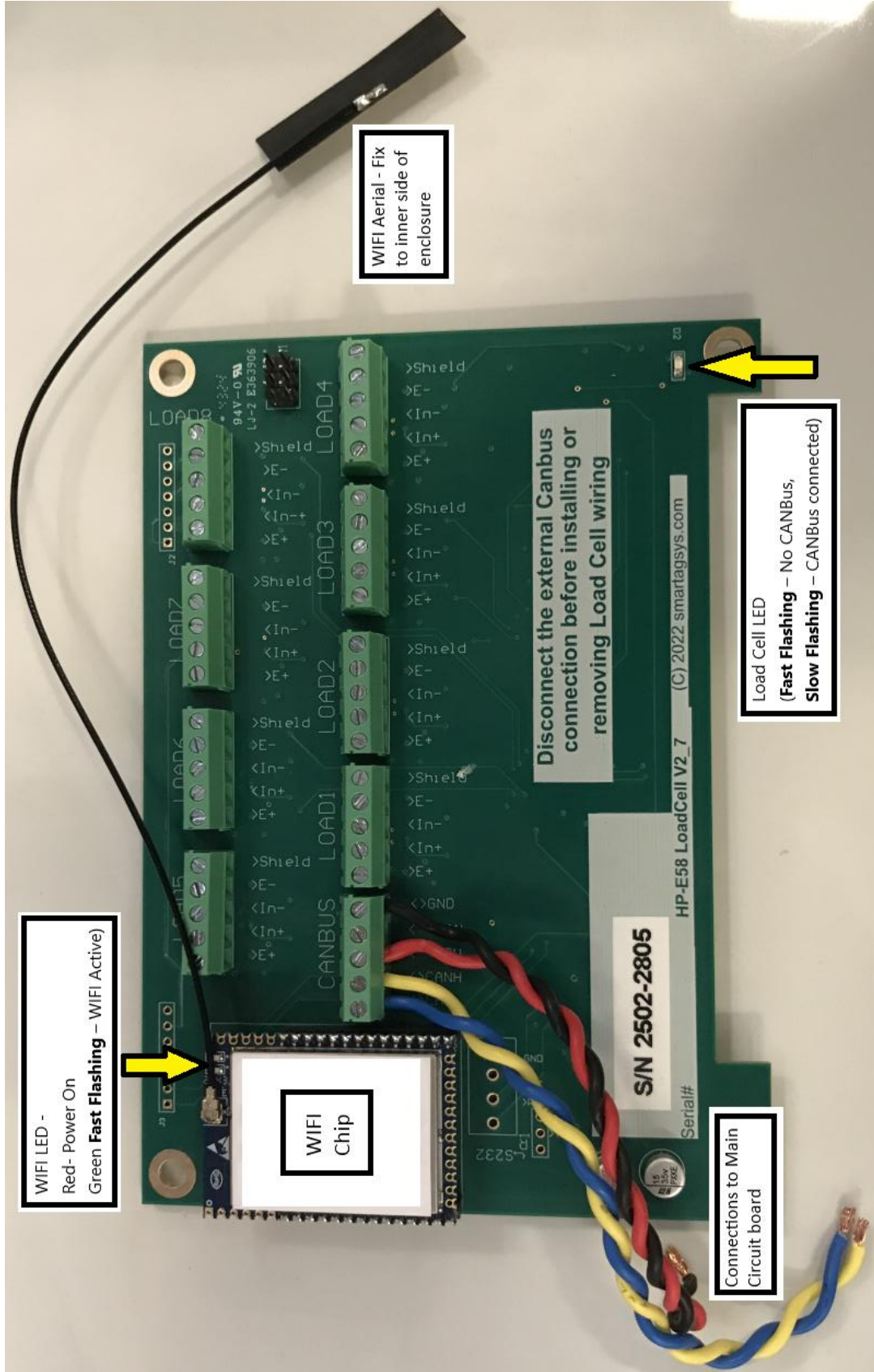

Phone Scales WIFI chip

- Fitted in place of WIFI chip when Phone scales display is Optioned

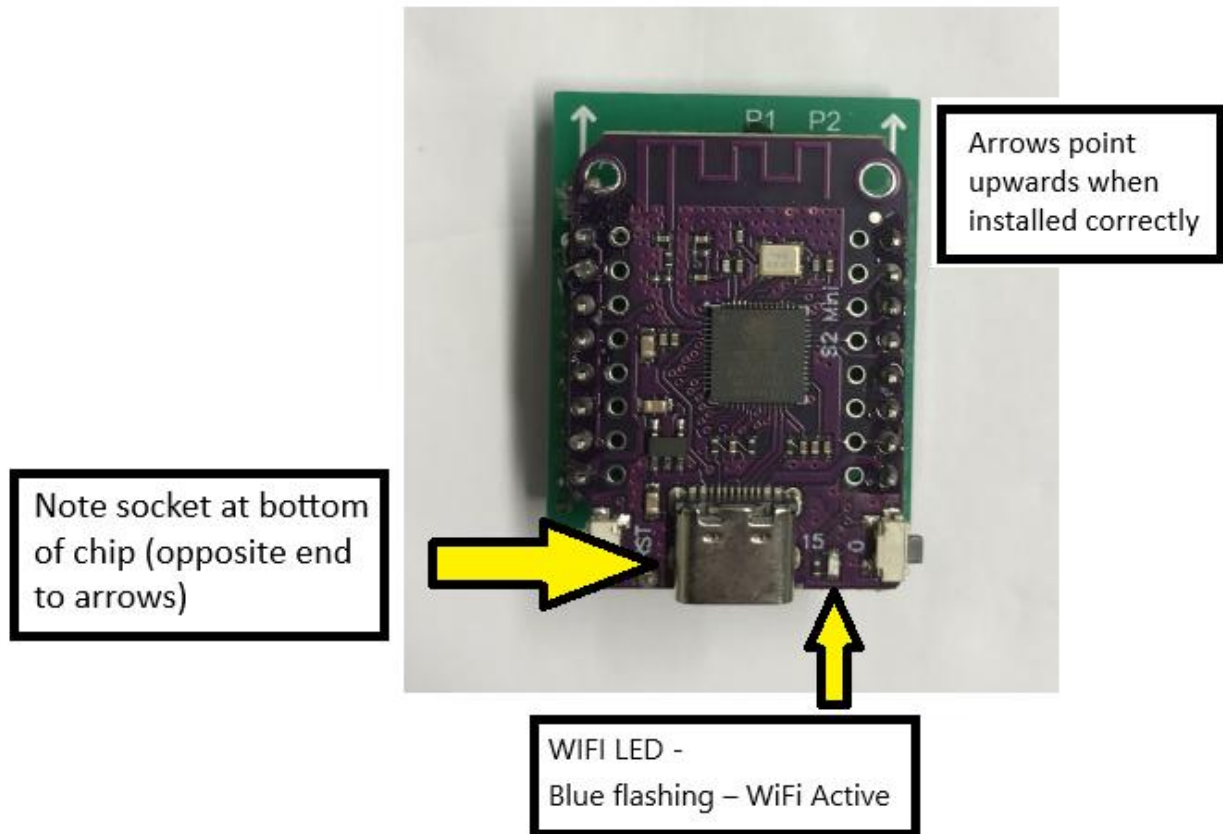

---

## Troubleshoot - Diagnostic Notes

**The tractor should be Turned Off for safety. Start the tractor only when required to test electronic control of a hydraulic function.**

**Follow all necessary safety precautions.**

Ensure the Electronic control system is turned on. The monitor in the cab will power up. If phone scales only is optioned, ensure the tractor loom LED is lit up to indicate 'On.'

Ensure the Tractor loom is plugged in to the Implement loom and the latch lever is clicked in place.

Remove the Electronic enclosure lid and observe which LED's are illuminated.

D1 - Battery LED – This LED remains on at all times, whether the wagon is connected to the tractor or not. If this LED is not On, the battery may be disconnected, discharged, or the fuse blown. If the LED is glowing faintly, the battery may be discharged. This can cause the system to not operate in Standby mode.

D2 - +12V – This LED is On when there is power connected coming from the Tractor AND the Tractor loom switch is On. If not on, check the plug and wiring to Tractor.

NOTE: In order for the Tractor power to be connected to the circuit board, the switching wires must be connected to 'CAN from tractor +12V / GND' terminals.

D3 – Operator LED – This LED operates in conjunction with the LED in the push button. When On, the system is operating on tractor power. When Flashing it is running on wagon battery power. When Off, the system is off. Either press the button or connect tractor plug (ensuring tractor loom is switched On) to turn On the system. If the LED on the circuit board is operating, but the button is not, check the button and its' wiring.

D4 – Load Cell Power – This indicates when power is available on the board for the load cell board. It is turned On whenever the system is On.

D5 – Floor Control – This indicates when power is being sent to the main wagon floor control valve. It is illuminated when the wagon is running. If the wagon floor does not move when the LED is On (and tractor hydraulics are engaged), check the following items:

- Set feed mode to 'Standard.' Increase feed percentage on the touchscreen – too low and the floor won't move.

- Wind manual override knob of floor control in. If wagon floor starts to move, the wiring or coil on the floor control cartridge on the hydraulic block may be faulty. If the wagon still does not start, go to hydraulic troubleshoot guide.

---

D6 - Elevator Control - This indicates when power is being sent to the elevator On/Off control valve. It is illuminated when the wagon is running. If the elevator does not move when the LED is On (and tractor hydraulics are engaged), check the following items:

- Manually override the elevator control by turning the knob anti clockwise until it clicks. If the elevator starts, the wiring or coil on the elevator control cartridge on the hydraulic block may be faulty. If the elevator still does not start, go to hydraulic troubleshoot guide.

Charge LED – On when system is charging the battery. Note the system senses when a battery is connected and begins charging. If Off when power is connected, the wiring to the battery, fuse or the battery itself may be faulty.

Status LED – On when power is coming in from Tractor, Flashing when battery power is being used. See D3 – Operator LED.



Load Cell LED – Slow Flashing when CANBus is connected (when tractor is plugged in), Fast flashing when no CANBus is connected (running on wagon battery). Off means no power is getting to load cell board. Check wiring connections between load cell board and main base circuit board.

WIFI chip LED's – Red – Power On AND Green fast flashing – WIFI Active. The WIFI signal should be discoverable by the touchscreen monitor. Ensure the aerial is intact and fixed in place inside the enclosure.

Phone Scales WIFI chip LED - Blue flashing means WiFi Active. The WIFI signal should be discoverable by any device capable of receiving WIFI. Note the phone scales WIFI chip does not have an aerial.

## Troubleshoot - Loom Plug Wiring

- Notes: - Wires are connected based on numbered positions on both plugs.
- The numbers can be found on the 'back' side of the plug once disassembled, where the wires actually fit in to the screw blocks.
  - A sticker is fitted where the wires fit in showing the wire number and colour.
  - When the sticker is missing or unreadable the numbers can be found moulded into the plug, sometimes under the sticker.

Tractor Loom Plug		Implement Loom Plug	
			
Wire Colour	Pin	Wire Colour	Function
RED	1	RED	+12V Power from tractor
GREEN	2	BLACK	GND CAN from tractor
-	3	-	-
BLACK	4	BROWN	GND Power from tractor
ORANGE	5	WHITE	+12V CAN from tractor
YELLOW	6	WHITE/GREEN	CAN-H
BLUE	7	WHITE/BROWN	CAN-L

## Technical - Hydraulic System Troubleshoot

When using the guide, it has been assumed that the tractor has been checked to provide an oil flow rate of between 30 and 60 litres per minute at full working pressure, usually 2200psi (150 bar) or greater. If these conditions are not satisfied, the forage wagon will perform poorly or not at all.

Please refer to the valve layout diagram on the next page to identify the location of the various valves discussed in the guide.

### Notes:

- To allow for lower flow tractors (30l/min and below), cartridge #4c can be changed with other types of valve cartridges to change the floor and elevator motor circuit from a parallel to a series circuit to reduce the oil flow requirement. Please note that this arrangement will cause the machine to run with acceptable speed but reduced power compared to the parallel circuit.
- Cartridge #4c (as fitted as standard) is a check valve (CXDA) for a permanent series connection between the floor and elevator motors. By replacing this with a cavity blank (XFOA) permanent parallel connection is achieved.
- By replacing cartridge #4c with a free flow reverse needle valve (NCCB), it is possible to convert the circuit between series and parallel in the field by winding fully in for series or fully out for parallel.
- Changing cartridge #4c from CXDA to SCCB (set @ 1700psi) will provide pressure relief when the floor is reversed. When relief pressure is reached, the conveyor belt will begin to operate in reverse.
- Machines that develop or operate with a jerking or shuddering action can be rectified by fitting a non-standard inline valve (SCCB 154Z P8) with relevant fittings between the port marked 'ELEV PRES' and the elevator motor. This preloads the hydraulic circuit and smooths the operation.

Note: This procedure was written specifically for Giltrap machines fitted with the 4045A valve assembly (stamped on the block itself).

If you have an older Giltrap model, contact Giltrap Engineering for advice or a different trouble shooting procedure.

### 4045A Valve Layout – Electronic Control

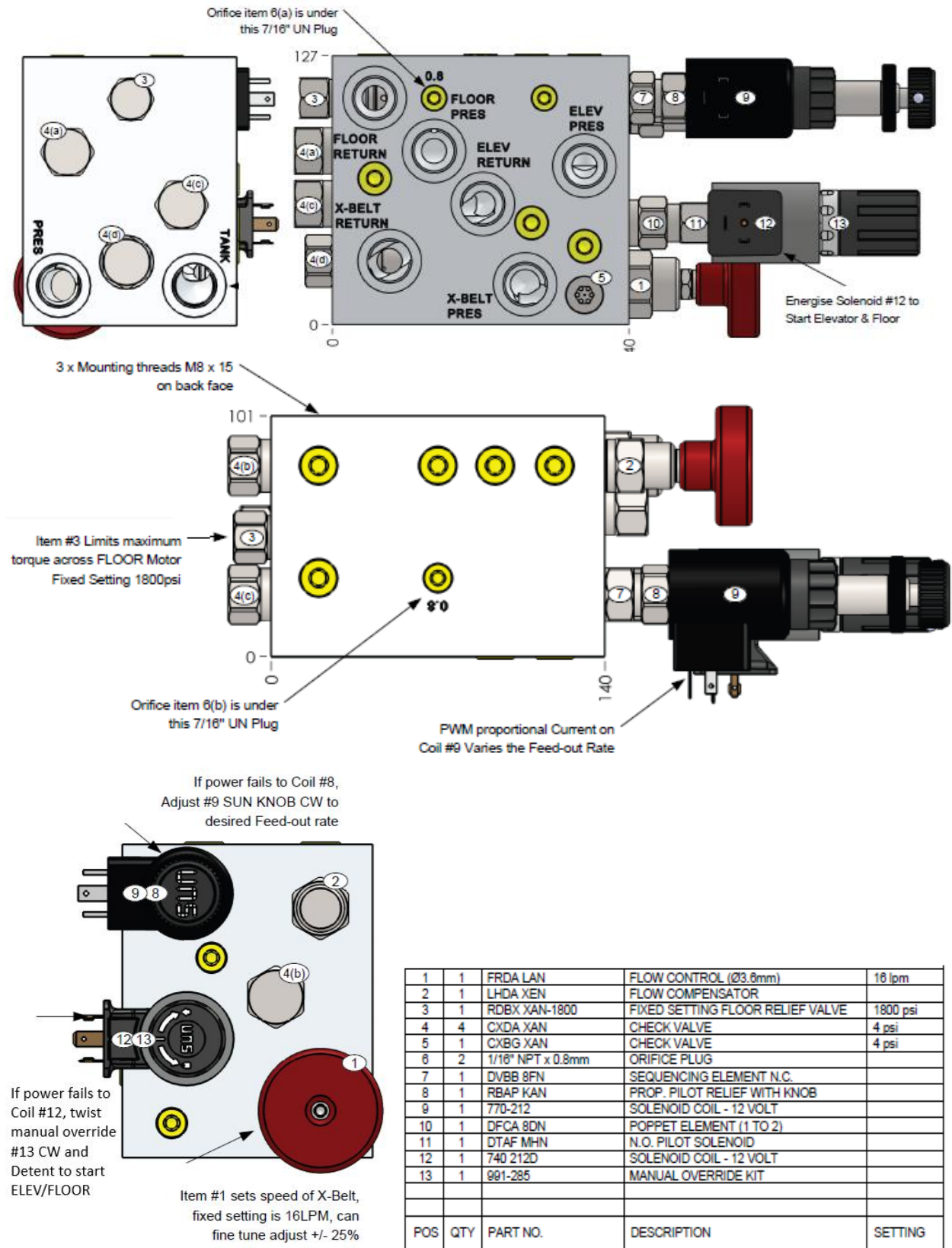

### 4045A Valve Layout – Manual Control

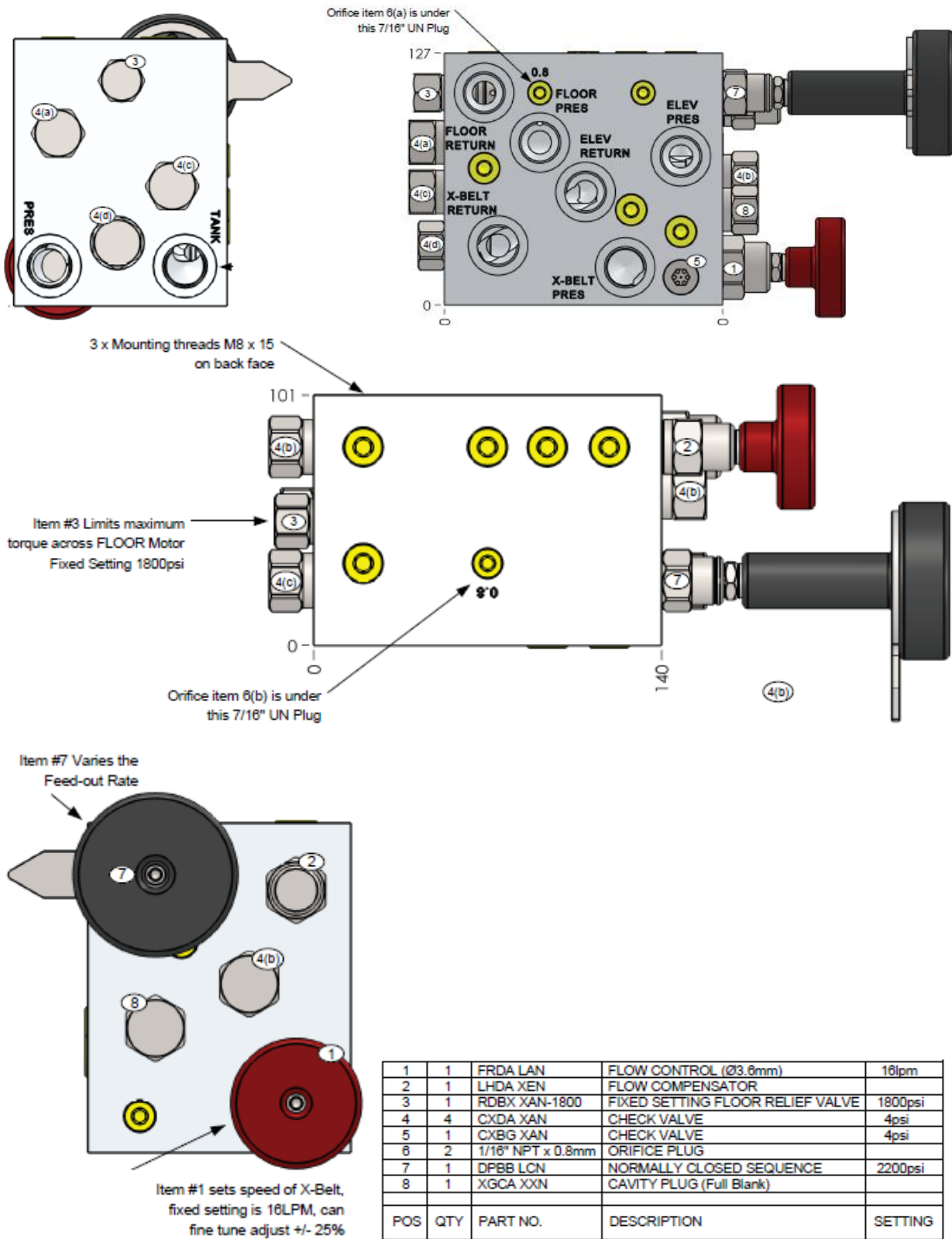

## Giltrap Wagon Check Sheet

New wagons are factory tested with a total operating pressure of about 1000psi.

Pressures higher than this are usually caused by a tight or off-centre conveyer belt, tight elevator and/or floor chains, or bearings that are seized or need greasing.

A conveyer extension belt (if fitted) will add 200-300psi to the operating pressure.

Tractors that are supplying greater than 60 litres/min may also cause additional back pressure and should be throttled back to the recommended flow parameters.

### Tips:

To isolate mechanical from hydraulic faults, motors can be mechanically uncoupled from the shaft they are powering and run with no load. If the high pressure reading drops dramatically with no load attached, it is generally safe to assume that the fault is mechanical (i.e. bent shaft, tight chains, collapsed bearing etc).

***If a problem persists, identify the operating symptoms and use the trouble shooting flow chart to isolate and rectify the problem.***

Contact your Giltrap dealer about our hydraulic block service-exchange programme

**FOLLOW 4045A with Electronic Control Trouble shooting chart**

**BEFORE 4045A Trouble shooting chart**

**4045A with Electronic Control**  
TROUBLE SHOOTING CHART

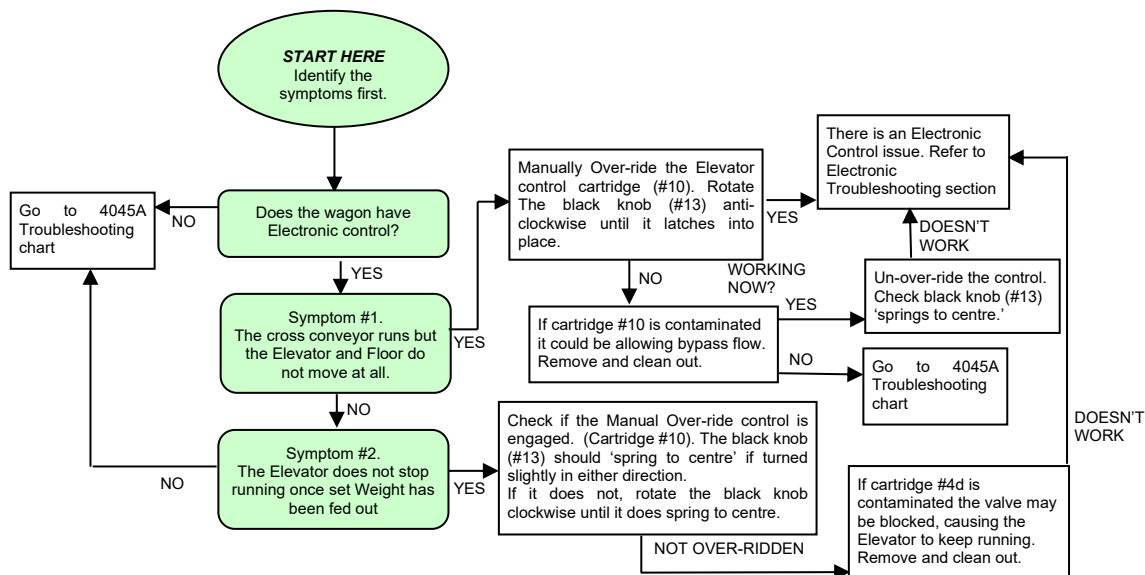

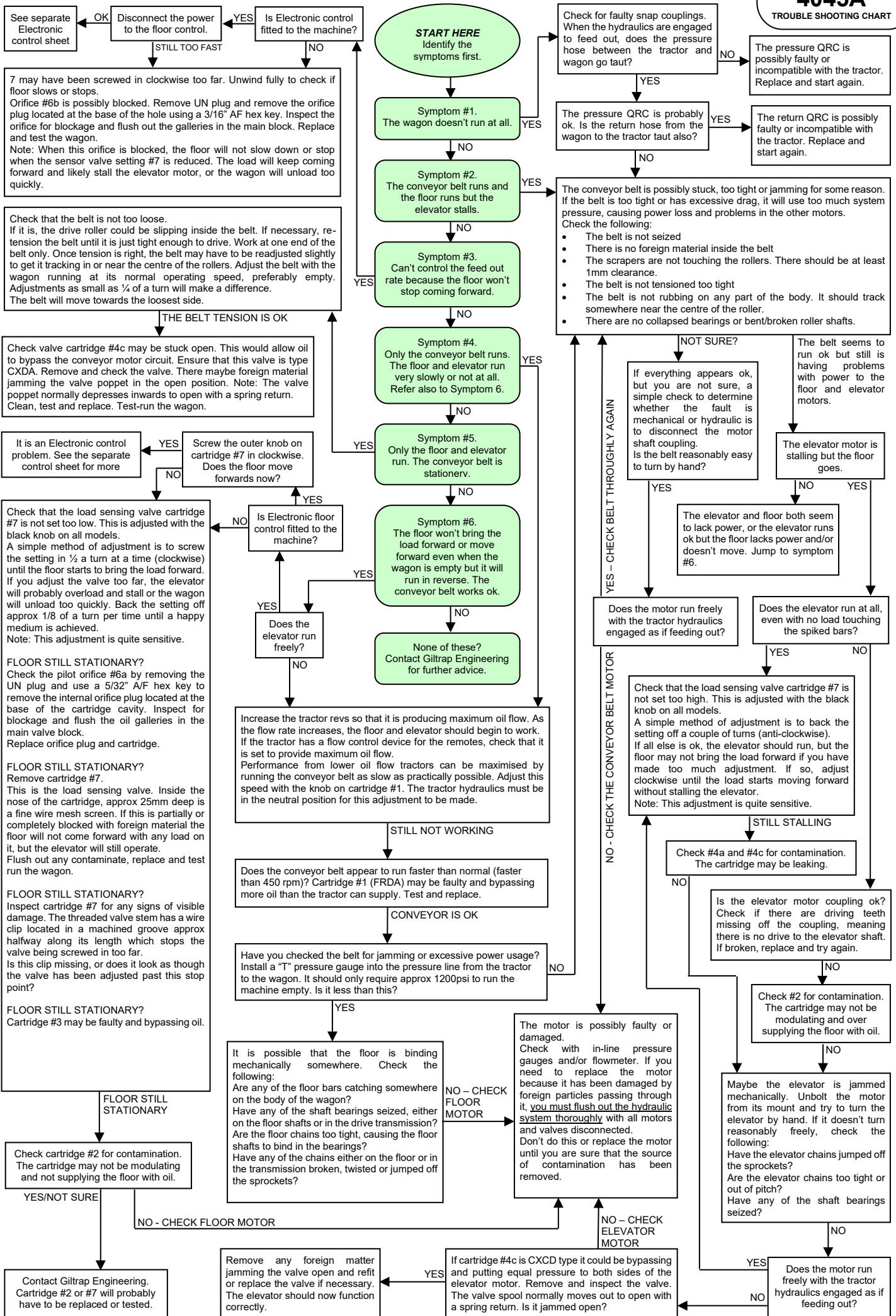

## Parts Section

ELECTRONIC CONTROL SYSTEM COMPONENTS .....	49
CHASSIS .....	51
LOAD CELL MOUNTS G-11 .....	53
LOAD CELL MOUNTS G-13 .....	54
DUMMY MOUNTS G-11 .....	55
DUMMY MOUNTS G-13 .....	55
RIMA JACK .....	56
FLOOR CHAIN DRIVE ASSEMBLY .....	57
FLOOR CHAIN IDLER ASSEMBLY .....	58
BELT CROSS CONVEYOR .....	59
CHAIN CROSS CONVEYOR .....	61
ELEVATOR ASSEMBLY .....	62
CONTROL ENCLOSURE COMPONENTS .....	63
GEARBOX RT120 .....	64
GEARBOX RT300 .....	65
MUDGUARDS .....	66
AXLE .....	67
HUB ASSEMBLY – ADR .....	68

## Electronic Control System Components

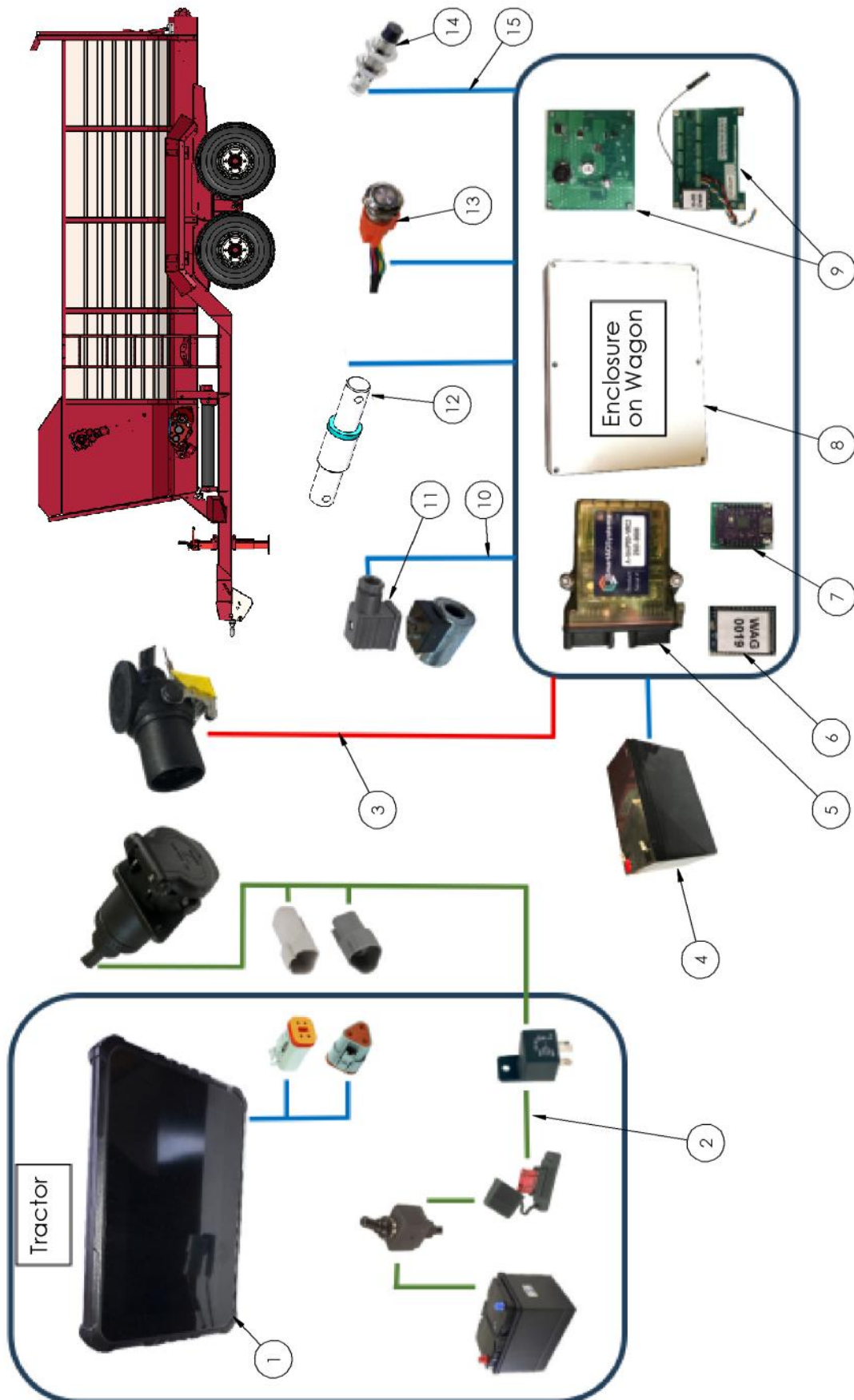

Electronic Option A - Wireless scales with manual floor control  
 Electronic Option B - Wireless electronic rate control without scales  
 Electronic Option C - Wireless scales and full automatic feed rate control  
 Electronic Option D - Phone based wireless scales with manual floor control

Item	Part Number	Description	Option A qty	Option B qty	Option C qty	Option D qty
1	7105Pro	7" Feed Wagon WIFI display	1	1	1	-
2	11660-LEV	Tractor Loom - Lever lock type	1	1	1	-
	15505	Tractor Loom - Phone Scales Display only	-	-	-	1
3	11647-LEV	Implement Loom, SmartAg - Fert Spreader and G-MAX	1	1	1	1
4	TCS-BATTERY2	Battery SLA 7.2Ah c/w F2 Terminals	1	-	1	1
5	A-Unipod-VRC-2	2 bin Unipod @ 5 buy price	-	1	1	-
6	A-WIFI-C	WIFI Chip Module - Wagon Controller with antenna	1	-	1	-
7	A-5009-W-GIL	WIFI Chip Module- Phone	-	-	-	1
8	K-5100-BB-01	Base Box	1	1	1	1
9	K-5100-LC-01	Load cell addition	1	-	1	1
10	#ES-2C	Dual Core Wire for Coil	-	Measure to Order	Measure to Order	-
11	11695	DIN Coil Plug	-	2	2	-
12	ES-DG8700/54	Load Cell 54mm 4000kg Buckton	3	-	3	3
13		Standby Button (supplied with Base Box)	1	-	1	1
14	TCS-OEM-PROX	Proximity Sensor - Omron	-	-	1	-
15	11657	Sensor Cable - Straight Plug - 10m	-	-	1	-

## Chassis

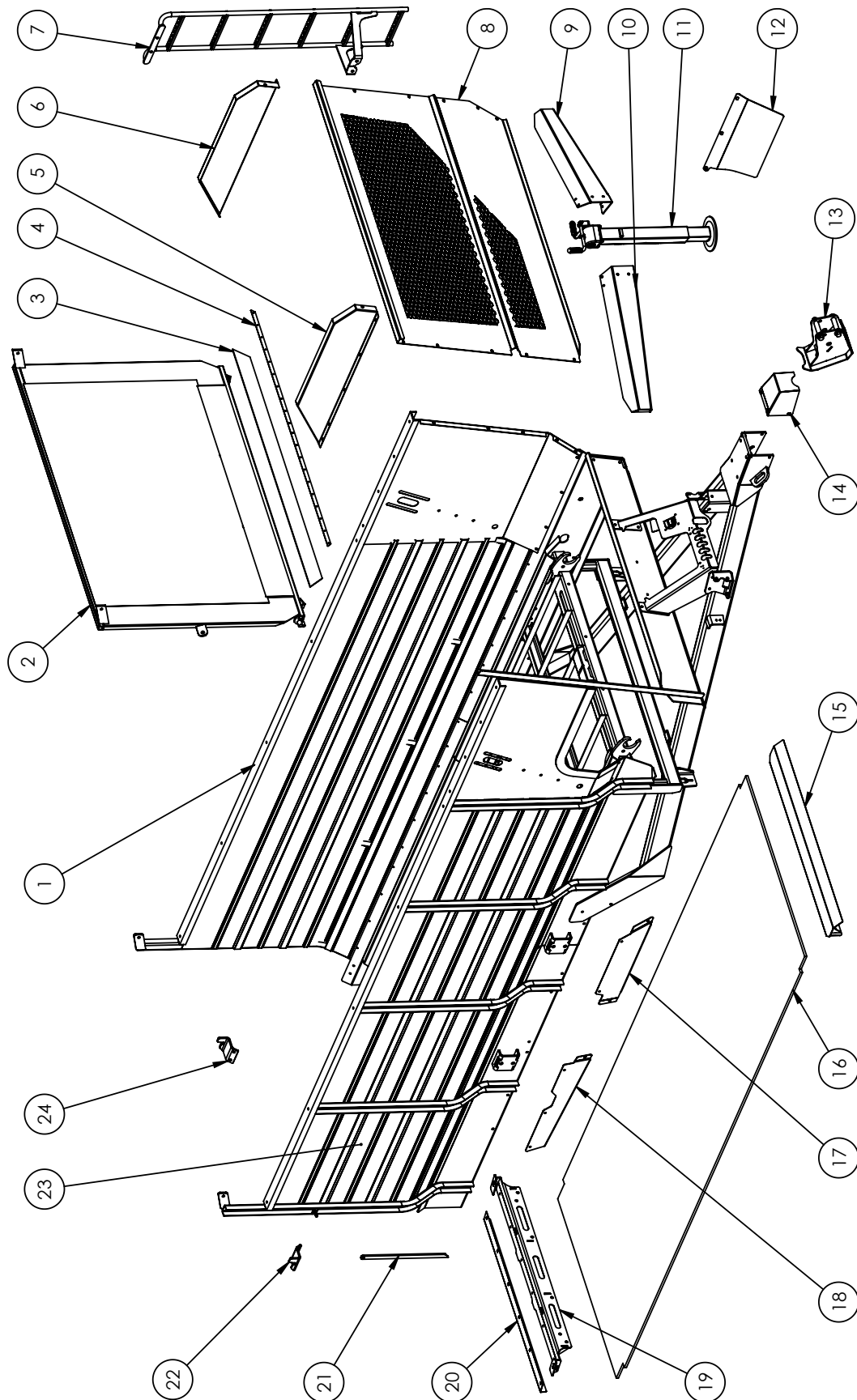

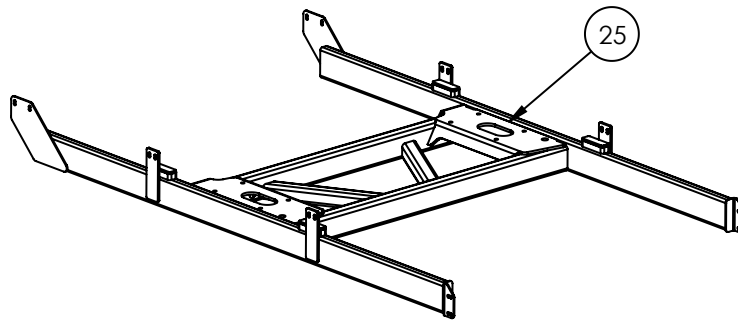

Refer view previous page and above

Item	Part Number	Description	Qty G11	Qty G13
1	15676	G11 chassis fabricated	1	-
-	15814	G13 chassis fabricated	-	1
2	50135	Rear Gate (includes items 3 & 4)	1	1
3	50136	Rear rubber flap	1	1
4	50223	Rear flap retainer	1	1
5	15699-RH	Top panel – right hand	1	1
6	15699-LH	Top panel – left hand	1	1
7	15664	Ladder	1	1
8	15700	Front panel	1	1
9	15704-LH	Bumper – left hand	1	1
10	15704-RH	Bumper – right hand	1	1
11	301-4020	Jack	1	1
12	15706	Deflector	1	1
13	15697	Quick hitch foot	Optional	Optional
14	15695	Cover	1	-
-	15820	Cover	-	1
15	15663	Guard	1	1
16	15665	G11 floor	1	-
-	15723	G13 floor	-	1
17	15688	Forward fill	1	-
18	15689	Rear fill	1	-
19	15660	Floor retainer	1	1
20	15703	Retainer cap	1	1
21	699-1002	Gate stay	1	1
22	BUC052-RH	Rear gate catch – right hand	1	1
23	Stainless Side	Cut length as required	2	2
24	BUC052-LH	Rear gate catch – left hand	1	1
25	15828	G13 Subframe	-	1

### Load Cell mounts G-11

Rear mount  
 (left side shown)

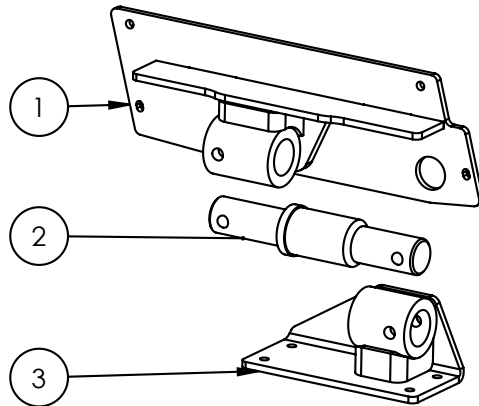

Tow Eye mount

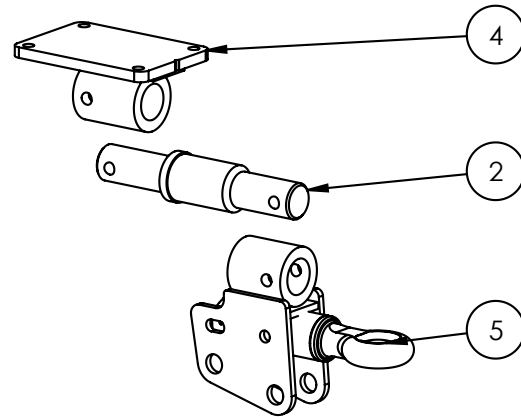

Item	Part Number	Description	Qty G11
-	15646	Rear Mount set (left and right hand of items 1 & 3)	1
1	15648-LH	Upper mount – left hand (shown)	1
-	15648-RH	Upper mount – right hand	1
2	ES-DG8700/54	54mm Loadcell	3 (optional)
3	15647-LH	Lower mount – left hand (shown)	1
-	15647-RH	Lower mount – right hand	1
-	15692	Tow Eye assembly (items 4 &5)	1
4	15694	Tow eye upper	1
5	15693	Tow eye lower	1

Note: Where load cells are not fitted, fit 54mm dummy load cell Part no: 50481

### Load Cell mounts G-13

Rear mount

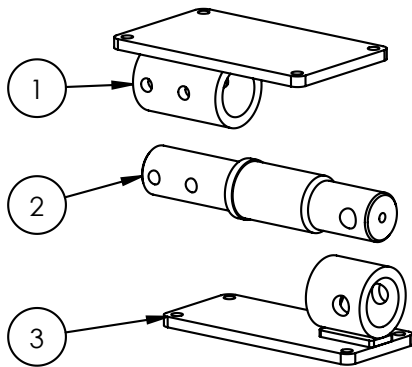

Tow Eye mount

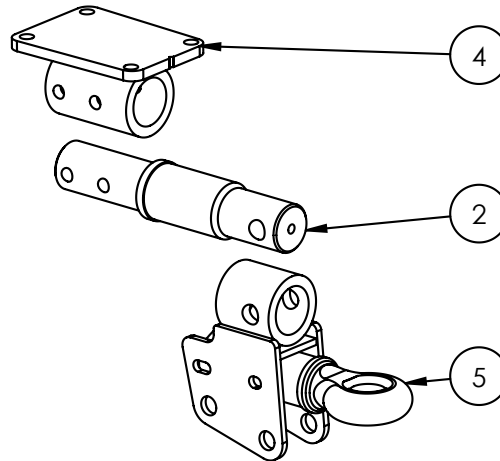

Item	Part Number	Description	Qty G13
-	15833	Rear Mount set (items 1 & 3, qty 2 off each)	1
1	15832	Upper mount	2
2	ES-DG22000/73	73mm load cell	3 (optional)
3	15831	Lower mount	2
-	15817	Tow eye assembly (items 4 & 5)	1
4	15819	Tow eye upper	1
5	15818	Tow eye lower	1

Note: Where load cells are not fitted, fit 73mm dummy load cell Part no: 12679

### Dummy mounts G-11

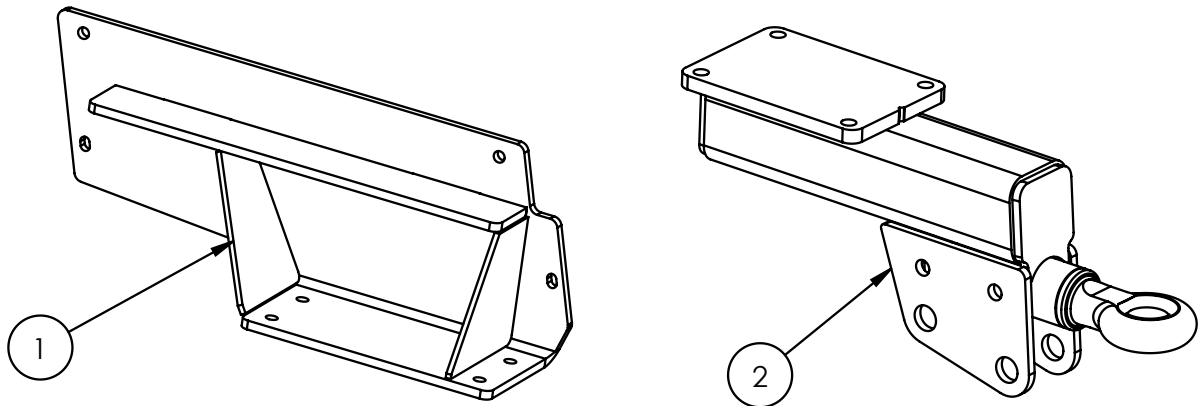

Item	Part Number	Description	Qty G11
1	15698-LH	Axle mount – left hand (shown)	1
-	15698-RH	Axle mount – right hand	1
2	15696	Tow eye mount	1

### Dummy mounts G-13

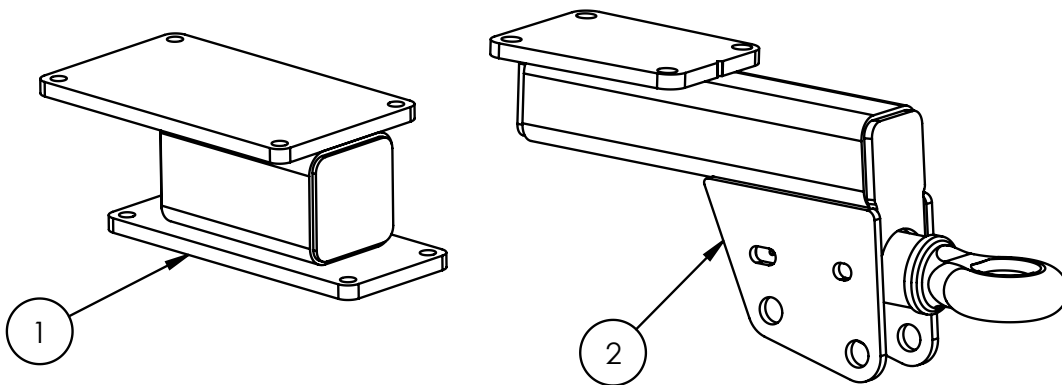

Item	Part Number	Description	Qty G13
1	15925	Axle mount	2
2	15924	Tow eye mount	1

## Rima Jack

### RIMA Parking Jack

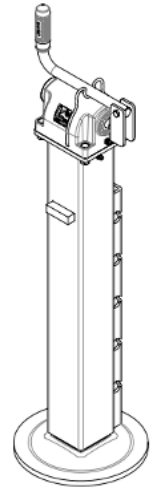
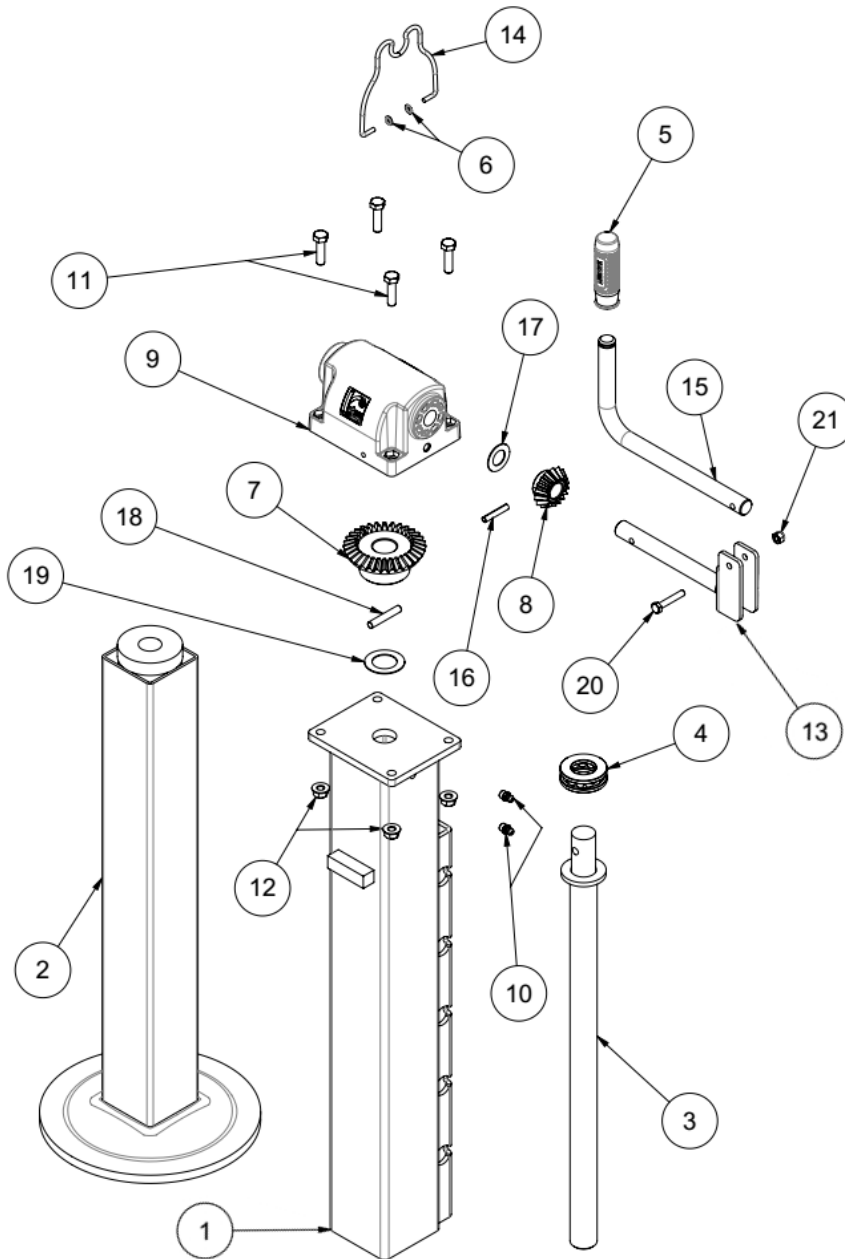

21	90064755	1
20	90076770	1
19	90068800	1
18	90070956	1
17	90068720	1
16	90071940	1
15	900411324	1
14	900416341	1
13	979303981	1
12	90064766	4
11	90079350	4
10	90039930	2
9	90049035	1
8	90033262	1
7	90033253	1
6	90069014	2
5	90041090	1
4	90034200	1
3	90057712	1
2	940655403	1
1	940275933	1
Item:	Code:	Q.ty:

## Floor Chain Drive Assembly

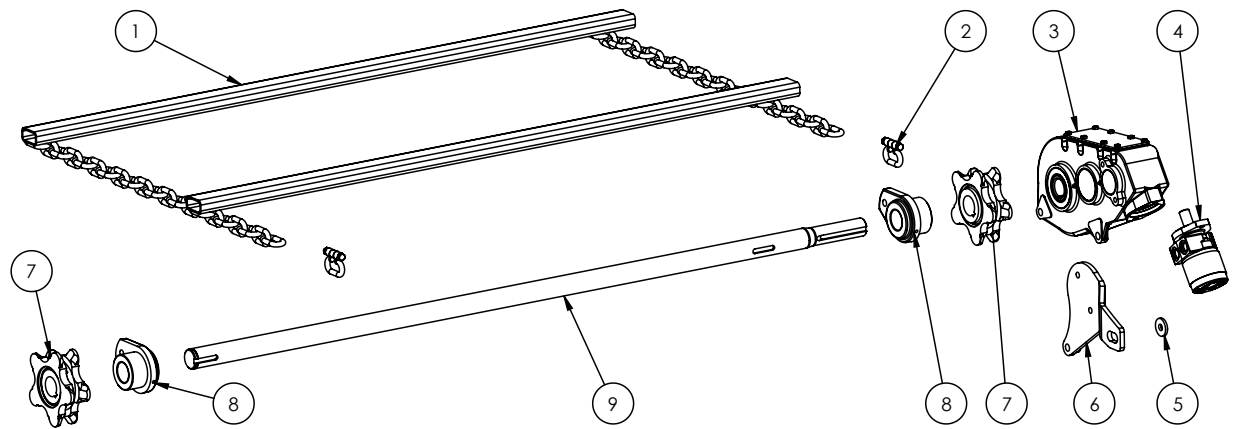

Item	Part Number	Description	Qty G11	Qty G13
1	Floor Chain – G11	Chain and Bar set	1	-
-	Floor Chain – G13	Chain and Bar set	-	1
2	230-1307	Chain Joiner 13mm	2	2
3	GBRT300-45-PT	Gearbox Berma RT300-45 Painted	1	1
4	HYM130-PT	Hydraulic Motor TEO130cc Painted	1	1
5	14659	Retainer Washer	1	1
6	14851	Gearbox torque arm	1	1
7	14962	5T 50mm Drive Sprocket	2	2
8	615-2044	Deadeye bearing 50mm	2	2
9	15658	Floor Drive shaft	1	1

## Floor Chain Idler Assembly

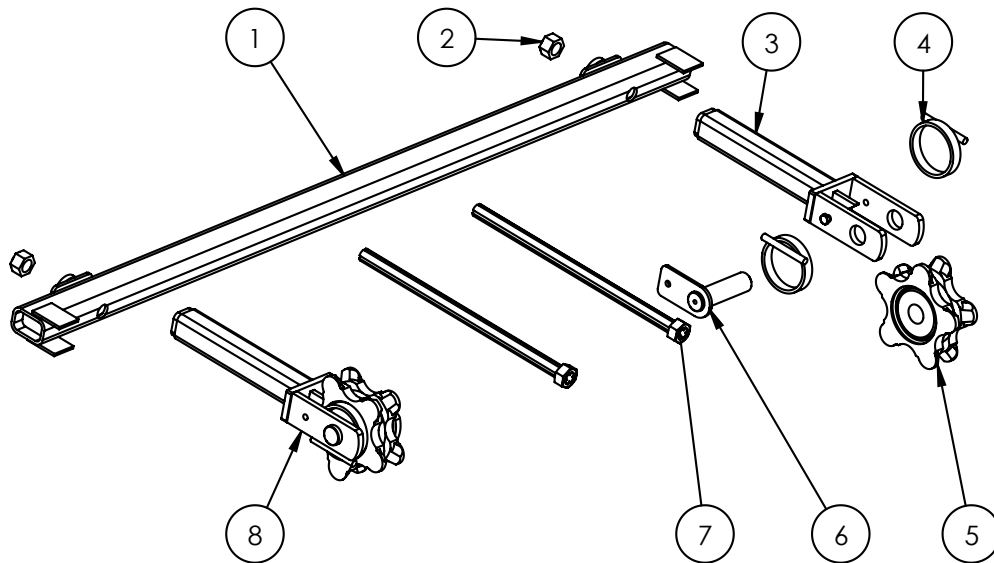

Item	Part Number	Description	Qty G11 and G13
1	15657	Puller	1
2	NN24	Nylock Nut M24	2
3	15655	Adjuster frame	2
4	15656	Large chain ring	4
5	15667	Five tooth Idler	2
6	15714	Idler shaft	2
7	14042	Tensioner rod	2
8	15654	Sprocket Adjuster Assembly (Includes items 3-6)	2

## Belt Cross Conveyor

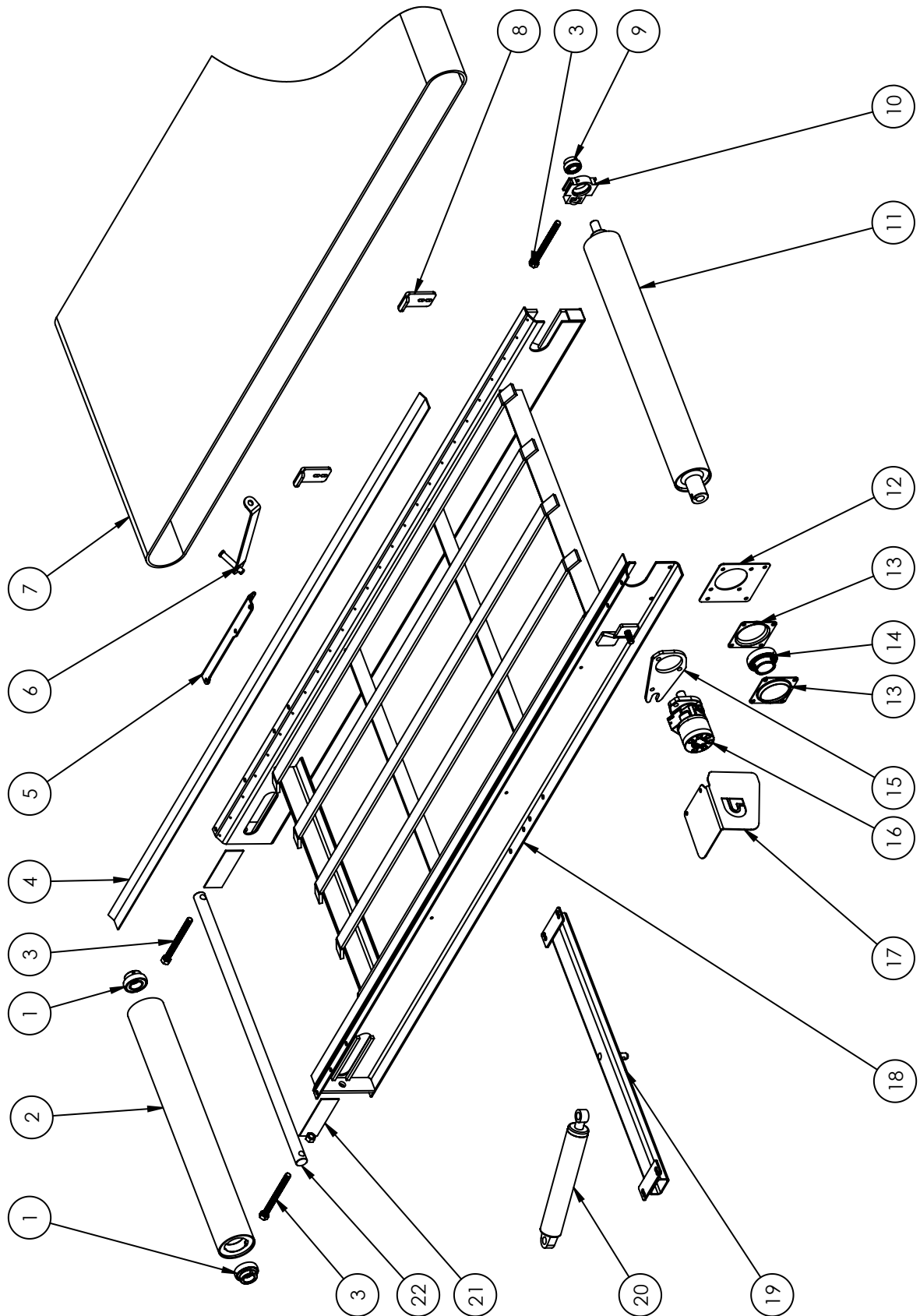

Refer view previous page

Item	Part Number	Description	Quantity G-Series
-	CCBED-GIL	Complete Assembly. DOES NOT include items 5,6,8,17,19,20	1
1	BRGYET207	BRG INSERT w/COLL 35mm	2
2	S13062-1	IDLER ROLLER ASSEMBLY	1
3	596-1004	ADJUSTER SCREW	3
4	60x3.2 UMPY	C/C BED STRIP - Buckton	2
5	15705	Width Setter	1
6	15668	Cross Conveyor Locator	1
7	S13063-900-5.00	CONVEYOR BELT 0.9 x 5.0m	1
8	14099	Holder	2
9	BRGYET205	BRG INSERT w/COLL 25mm	1
10	HSGTU505	TAKE UP HOUSING 25mm	1
11	S13056-1	DRIVE ROLLER ASSEMBLY	1
12	BUC-047	CONVEYOR BEARING MOUNT	1
13	BUC-048	CONVEYOR BEARING SHELL	2
14	BRGYAR210-2F	BRG INSERT 50mm	1
15	BUC-095	MOTOR MOUNT	1
16	HYM65-PT	Hydraulic motor 65cc 25mm shaft	1
17	15707	Guard	1
18	780-BUC Bed	Bed Frame	1
19	50766	Underbed Side-Shift beam	Optional
20	Compact2x1x10	10" Side Shift ram	Optional
21	780-2006	ADJUSTER NUT SLIDE	2
22	S13061	Shaft	1

### Chain Cross Conveyor

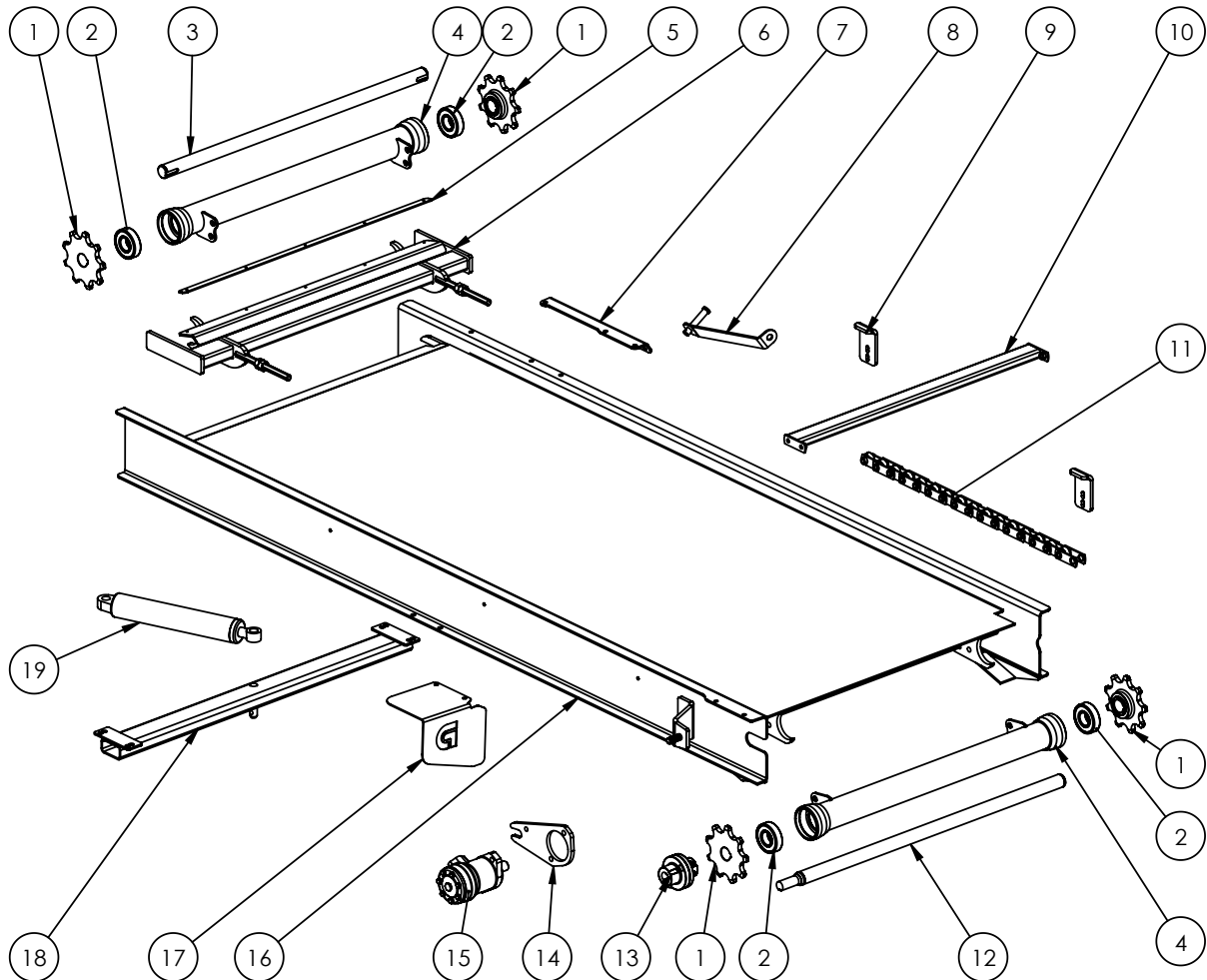

Item	Part Number	Description	Quantity G-Series
-	15729	Complete Assembly. DOES NOT include items 7,8,9,17,18,19	1
1	211-0007-1	Sprocket	4
2	BRG6307	Bearing	4
3	510-1075	Idler shaft	1
4	501-8015	Bearing housing	2
5	15739	Retainer	1
6	15735	Adjuster assembly	1
7	15705	Width Setter	1
8	15668	Cross Conveyor Locator	1
9	14099	Holder	2
10	501-8012-1	Cross beam	As required
11	CH6000-2	2inch pitch chain	As required
12	510-1074	Drive shaft	1
13	554-1136	Motor Coupling - Male	1
-	554-1143	Motor Coupling - Female	1
14	BUC-095	MOTOR MOUNT	1
15	HYM80-PT	Hydraulic Motor 80cc Brevini, Painted	1
16	15730	Chain Bed frame	1
17	15707	Guard	1
18	50766	Underbed Side-Shift beam	Optional
19	Compact2x1x10	10" Side Shift ram	Optional

## Elevator Assembly

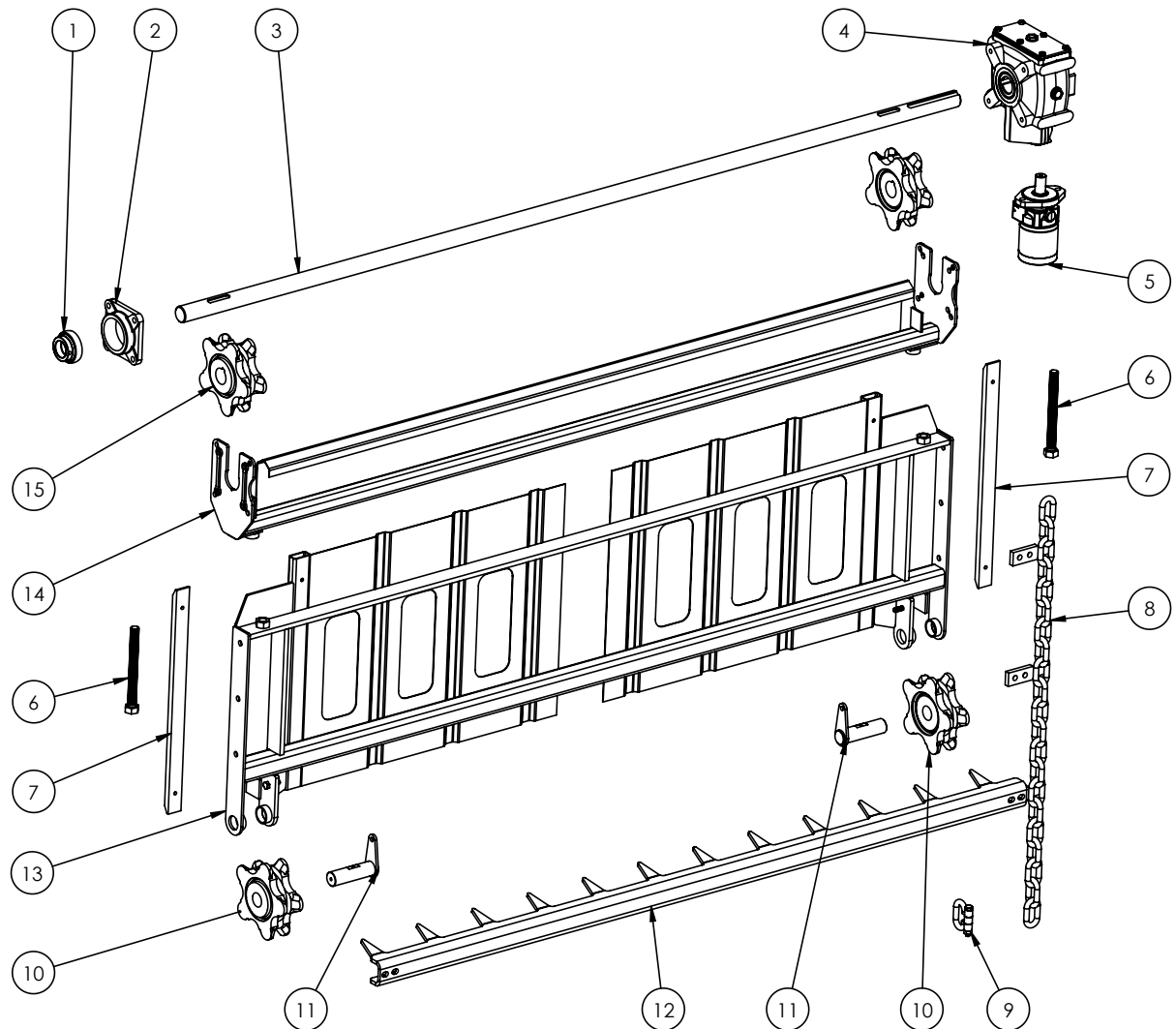

Item	Part Number	Description	Quantity G-Series
1	BRGYET208	BRG insert w/COLL 40mm	1
2	HSGF208	Bolt flange housing 40mm	1
3	15691	Drive shaft	1
4	GBRT120/40-PT	Gearbox	1
5	HYM195	Hydraulic motor	1
6	14824	Adjuster bolt	2
7	15727	Plastic pad	2
8	-	Elevator chain (pair)	1
9	230-1307	Chain Joiner 13mm	2
10	15667	Five tooth idler	2
11	50809	Idler pin	2
12	15710	Elevator bar	6
13	15669	Lower frame	1
14	15670	Upper frame	1
15	12180	5T 40mm drive sprocket	2

## Control Enclosure Components

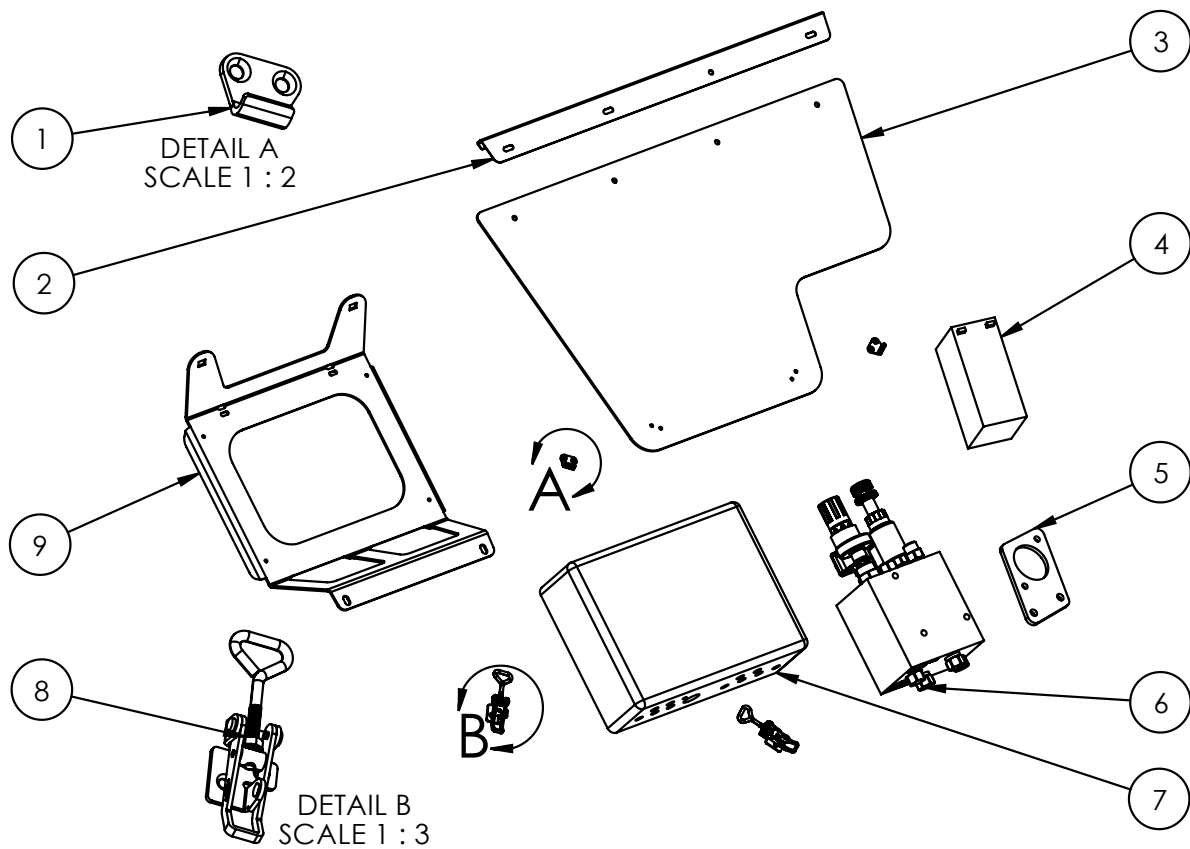

For Control System, see 'Electronic Control System Components'

Item	Part Number	Description	Quantity G-Series
-	15712	Front Cover (including items 1,2,3)	1
1	05704	Strike for latch	2
2	15712-2	Cover hook	1
3	15712-1	Plastic panel	1
4	TCS-Battery2	Battery	(Optional)
5	15741	Plug stowage	(Optional)
6	HYHCV-4045-2	Hydraulic valve block – (manual)	As req.
-	HYHCV-4045A	Hydraulic valve block – (Electronic)	As req.
7	Enclosure	see Electronic Control system components	As req.
8	05702	Hold down latch	2
9	15711	Enclosure mount	1

## Gearbox RT120

Riduttore RT120 Ø40			
CODICE 13039			
Fig.	Rif.	Descrizione	Qt.
1	13092	Scatola RT120	1
2	13094	Mozzo Ø40	1
3	13093	Corona Z=45	1
4	3429	Seeger E 65	1
5	13109	Cuscinetto 32012	1
6	3353	Cuscinetto 6012	1
7	3438	Seeger I 95	1
8	13091	Pignone Z=11	1
9	13108	Seeger E 50x3 inf.	2
10	10552	Cuscinetto 6010-2RS	1
11	1538	Cuscinetto 6010	1
12	3435	Seeger I 80	1
13	8889	Anello di ten. 60/95/10	1
14	3660	Anello di ten. 60/85/10	1
15	1714	Tappo scarico Ø11/2" Gas	1
16	5689	Tappo sfiato Ø11/2" Gas	1
17	8671	Guarnizione x motore	1
18	13097	Coperchio	1
19	13107	Guarnizione coperchio	1
20	1257	Spia liv. olio Ø11/2" Gas	1
21	3284	Vite TE M8x16-8G	6

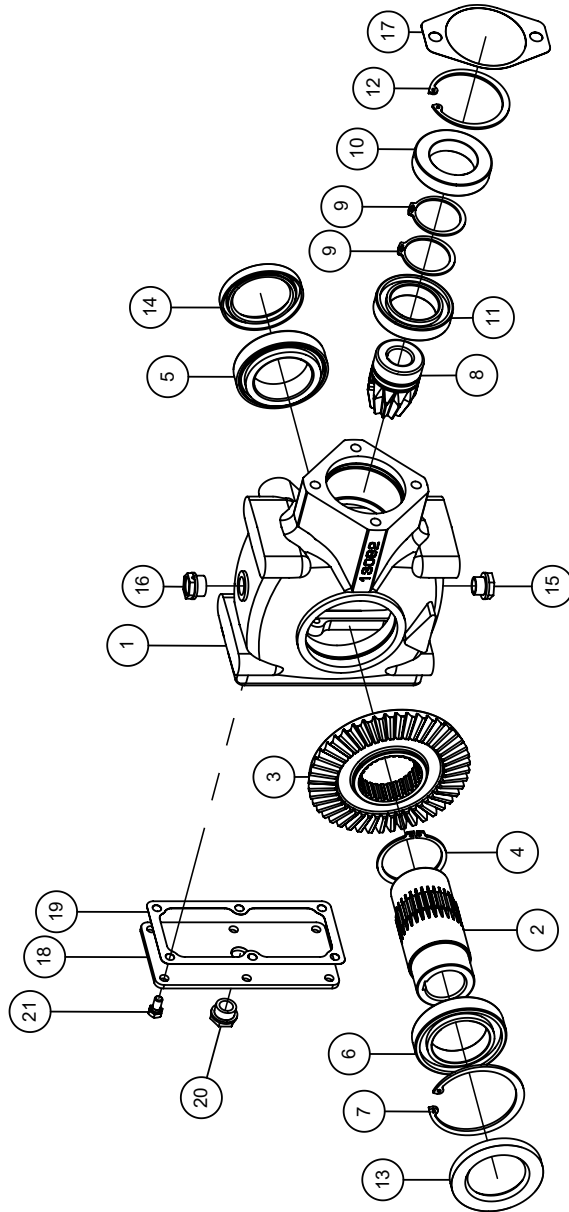

## Gearbox RT300

Riduttore RT300 Ø45			
CODICE 8670			
Fig.	Rif.	Descrizione	Qt.
1	8669	Scatola RT300	1
2	8670-8	Mozzo Ø45	1
3	8670-6	Ruota dentata Z=46	1
4	3439	Seeger I 100	2
5	8702	Cuscinetto 6013	2
6	8670-5	Pignone di rinvio Z=12	1
7	8670-4	Ruota dentata Z=50	1
8	4174	Chiavetta 12x8x30	1
9	3342	Cuscinetto 6208	2
10	3435	Seeger I 80	3
11	8670-3	Pignone di rinvio Z=10	1
12	8670-2	Corona conica Z=43	1
13	3396	Chiavetta 8x7x25	1
14	8596	Cuscinetto 6305	2
15	3433	Seeger I 62	2
16	8670-1	Pignone Z=28	1
17	1538	Cuscinetto 6010	1
18	3428	Seeger E 50	1
19	8701	Anello di ten. 65/100/10	2
20	8243	Tappo Ø80 sp. 10	2
21	8625	Tappo Ø62 sp. 10	2
22	8668	Coperchio RT300	1
23	8668-1	Guarnizione coperchio	1
24	9175	Tappo Ø1" Gas	1
25	1831	Spia liv. olio Ø1"Gas	1
26	3284	Vite TE M8x16-8G	8
27	8703	Seeger E 72	1
28	8671	Guarnizione x motore	1

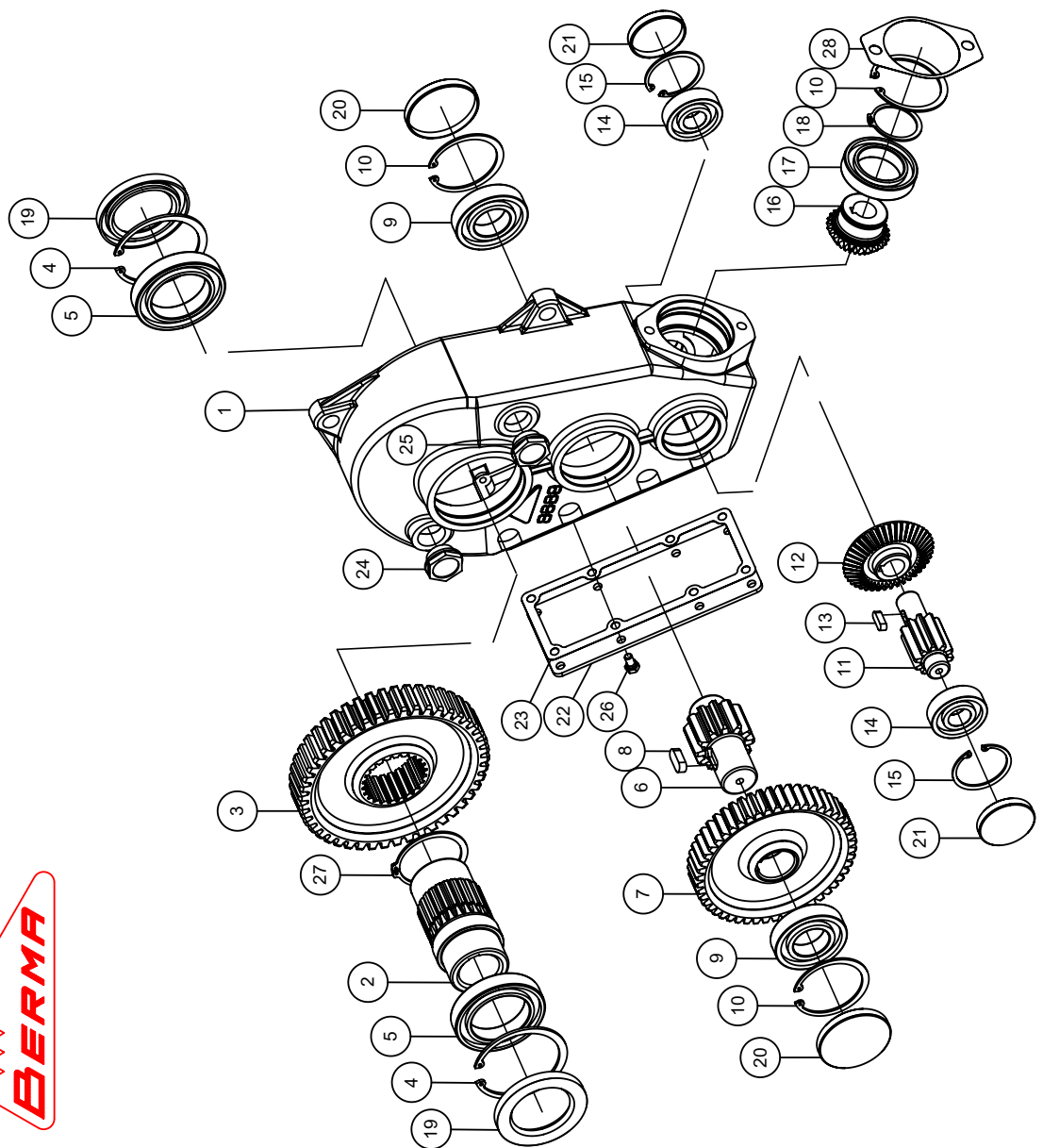

## Mudguards

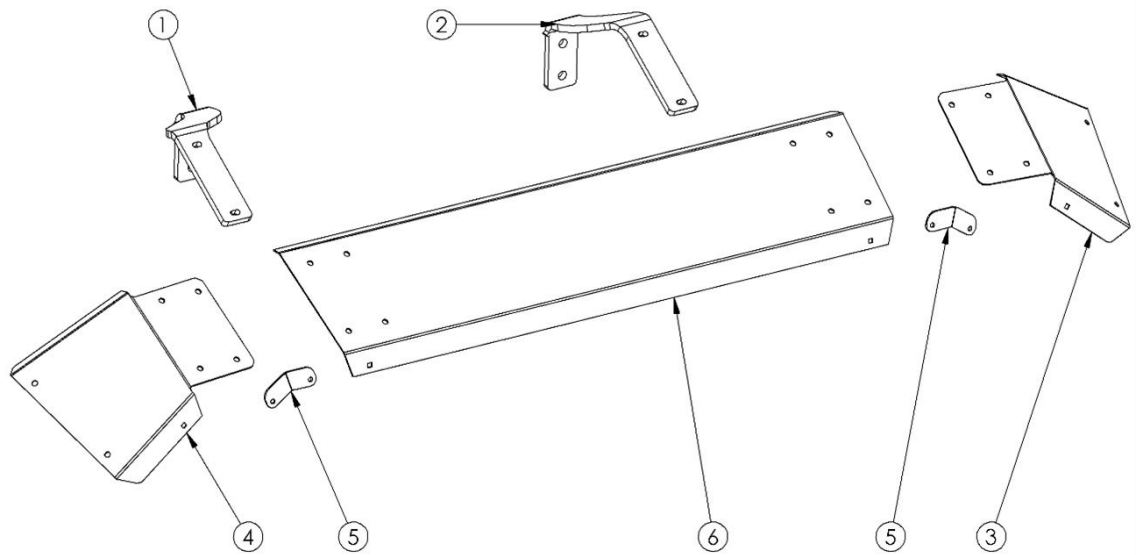

Item	Part Number	Description	Qty Tyre: 11.5/80-15.3	Qty Tyre: 400/60-15.5
1	15708-LH	Brace	2	2
2	15708-RH	Brace	2	2
3	14858-RH	Guard End Right hand	2	2
4	14858-LH	Guard End Left hand	2	2
5	14859	Edge Joiner	4	4
6	14900	Guard panel	2	2

Note: Left side guard shown. Right side guard is mirrored.

Quantities are per complete machine

If your tyre size is not listed, contact the Giltrap Parts Department

## Axle

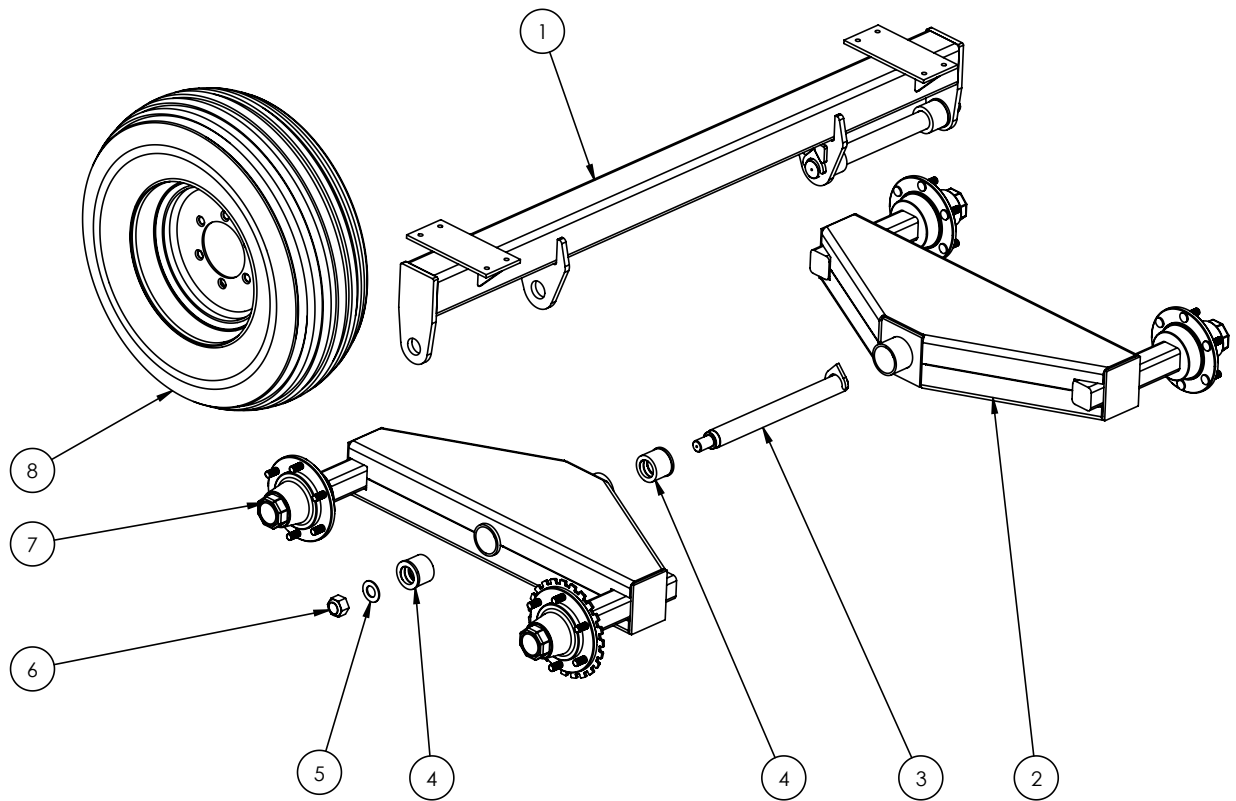

Item	Part Number	Description	Quantity G-Series
-	15661	Axle Assembly (Items 1-7)	1
1	15662	Cross beam	1
2	50334-RH	Walking beam Right hand	1
3	BEAPHD	Axle shaft	2
4	C28176	Axle bush	4
5	WA30	Washer	2
6	NNF1-1/4	Nyloc Nut UNT 1-1/4"	2
7	50334-LH	Walking beam Left hand	1
8	WHLA11.5/80-12	Wheel Assy 11.5/80 x 15.3	Confirm size fitted
-	WHLA400X15.5-146T	Wheel Assy 400/60 X 15.5	Confirm size fitted

### Hub Assembly – ADR

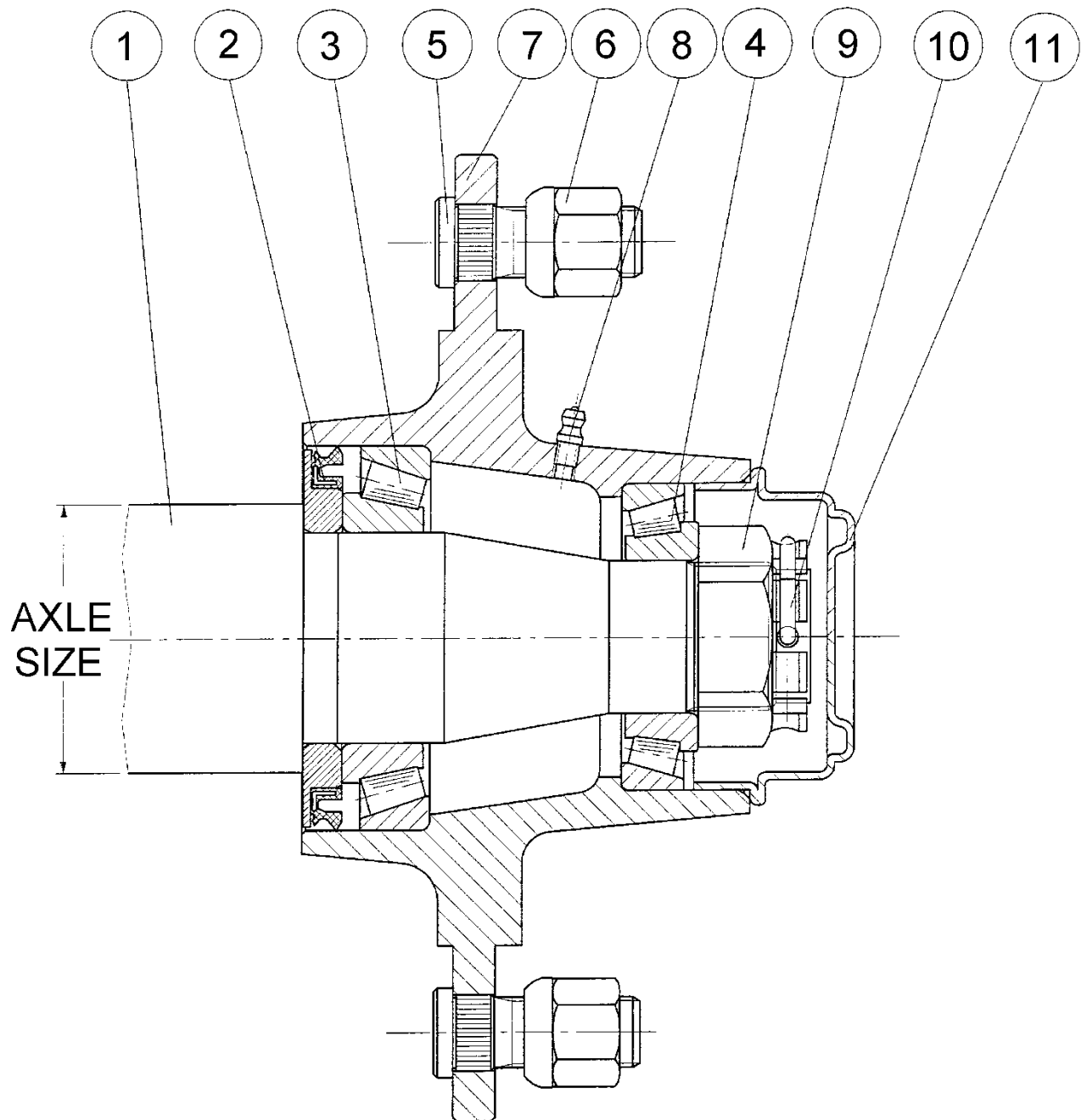

- See table next page

Refer view previous page

Item	Giltrap Part #	Description	Quantity			
			60mm	70mm	80mm	90mm
1	HUB2000KG	Complete Stub Axle, ADR 6 stud 60sq	1			
1	HUB3000KG	Complete Stub Axle, ADR 6 stud 70sq		1		
1	HUB4250KG	Complete Stub Axle, ADR 8 stud 80sq			1	
1	HUB5000KG	Complete Stub Axle, ADR 8 stud 90sq				1
2	110-0193	Seal 57x100x10 O/A (80x100x8 nom.)	1			
2	110-0194	Seal 67x120x12 O/A (100x120x10)		1		
2	110-0195	Seal 78x130x10 O/A (108x130x8)			1	
2	110-0196	Seal 82x140x10 O/A (119x140x8)				1
3	BRG30208J2	Taper Roller Bearing, 30208 J2	1			
3	BRG32210J2	Taper Roller Bearing, 32210 J2		1		
3	BRG32212J2	Taper Roller Bearing, 32212 J2			1	
3	BRG32213J2	Taper Roller Bearing, 32213 J2				1
4	BRG30211J2	Taper Roller Bearing, 30211 J2	1			
4	BRG30213J2	Taper Roller Bearing, 30213 J2		1		
4	BRG32215J2	Taper Roller Bearing, 32215 J2			1	
4	BRG32216J2	Taper Roller Bearing, 32216 J2				1
5	110-0945	Wheel Stud, M18x50	6	6	8	
5	110-0950	Wheel Stud, M20x60x1.5				8
6	110-0917	Wheel Nut, M18	6	6	8	
6	110-0919	Wheel Nut, M20x1.5				8
7	-	Hub Only	1	1	1	1
8	GRN8-45	Grease Nipple, M8x1.0 45 deg	1	1	1	1
9	110-1047	Slotted Nut, M39x1.5	1	1		
9	110-1060	Slotted Washer Nut, M48x1.5			1	1
10	-	Retaining Clip (or Split Pin SP5x70)	1			
10	-	Retaining Clip (or Split Pin SP5x70)		1		
10	-	Retaining Clip (or Split Pin SP5x80)			1	
10	-	Retaining Clip (or Split Pin SP5x90)				1
11	110-0799	Grease Cap ADR Pressed Steel -	1			
11	110-0881	Grease Cap ADR Pressed Steel -		1		
11	110-0883	Grease Cap ADR Pressed Steel -			1	
11	110-0884	Grease Cap ADR Pressed Steel -				1



We've assembled a comprehensive dealer network that knows what it takes to keep your Giltrap machinery in peak condition. With a blend of local knowledge and engineering expertise our team is here 24/7, so your business doesn't have to stop.

To find out more about our local dealer network or to discuss your specific needs, contact a member of our team.

NEW ZEALAND (HEAD OFFICE)  
TEL +64 7 873 4199  
EMAIL [info@giltrapag.co.nz](mailto:info@giltrapag.co.nz)  
[giltrapag.co.nz](http://giltrapag.co.nz)

AUSTRALIA  
TEL +61 3 9369 6548  
EMAIL [sales@giltrapag.com.au](mailto:sales@giltrapag.com.au)  
[giltrapag.com.au](http://giltrapag.com.au)

To find your local Giltrap and Duncan dealer visit  
[giltrapag.co.nz/our-dealers](http://giltrapag.co.nz/our-dealers)