

65 YEARS

100%
MADE IN
NZ

G
GILTRAP

Giltrap Slurry Spreader

Operation & Parts Manual

(All models)



Giltrap
ENGINEERING LTD
7500 SLURRY SPREADER

Disclaimer

Although every endeavour has been made to compile as near to complete records as possible for the machine described, it is possible some information is incomplete or missing.

Giltrap Engineering request that you treat this book as a guide only and offer any assistance necessary to procure the information or part you may require.

For parts or service enquiries, please contact the applicable numbers on the previous page.

Amended and reprinted February 2024

Copyright © 2024 by Giltrap Engineering Ltd.
Printed in New Zealand

All rights reserved. Reproduction or use, without express permission, of editorial or pictorial content, in any manner, is prohibited.

Table of Contents

INTRODUCTION	5
DELIVERY AND WARRANTY	5
GENERAL SAFETY	6
DRIVESHAFT SAFETY.....	9
PRE-SERVICE GUIDELINES & SETTINGS	9
SPREADING OPTIONS.....	11
GENERAL OPERATING INSTRUCTIONS	12
IMPORTANT	12
VACUUM PUMP INSTRUCTIONS & MAINTENANCE.....	13
1.0 - Starting.....	13
2.0 - Operation.....	14
4.0 - Technical.....	19
VACUUM PUMP SPECIFICATIONS – MEC/M SERIES.....	20
VACUUM PUMP SPECIFICATIONS –SE/D SERIES	20
VACUUM PUMP TROUBLESHOOTING.....	21
AUTO FILL OPERATION	23
HYDRAULIC SUSPENSION OPERATION AND INFORMATION.....	25
MAINTENANCE OF STOCK & CONSIGNMENT SLURRY TANKS.....	26
TANK ASSEMBLY FITTINGS	27
5000 & 7500.....	27
10000, 12000 & 15000	29
SLURRY TANK FITTINGS REFERENCE	32
Slurry Tank Fittings Reference	32
Slurry fittings and attachments	34
Rear & Top Hatch Assemblies.....	35
VACUUM PUMP PART BREAK DOWN.....	37
MEC6500/8000 Vacuum Pump with Overdrive.....	37
SE12000 Vacuum Pump.....	39
Vacuum Pump Lubrication – SE12000.....	42
Vacuum Pump Forced Lubrication (MEC5000 – 8000).....	43
Vacuum Pump Automatic Lubrication (MEC6500 – 8000).....	45
STAR 72 VACUUM PUMP PARTS BREAK DOWN	47
Star 72 M-Ma.....	47
Star 72 Lubrication Options	48
Star 72 Parts List.....	49
GEARBOX PARTS BREAK DOWN FOR RAIN GUN OPTION	55
Garda Gearbox 6500 Mechanical Seal.....	55
Garda Gearbox 6500 540/1000 Rpm with Pre-Shaped Ring.....	56
ADR Axle Hub.....	60
SINGLE AXLE ASSEMBLY - M5000	62
SINGLE AXLE ASSEMBLY – M7500.....	63

TANDEM AXLE ASSEMBLY - M5000 & M7500	64
TANDEM AXLE ASSEMBLY - M10000	65
STEERING AXLE PARTS BREAK DOWN	66
<i>Steering Axle Self-Steer</i>	66
<i>Steering Axle Power Steer</i>	67
<i>ARD Hub Assembly</i>	68
<i>Steering Axel parts list</i>	69
JACK ASSEMBLY	72
<i>Jack Assembly Parts list</i>	73
HYDRAULIC HOSE ASSEMBLY	74
<i>Hydraulic Suspension Parts</i>	76
OPTIONAL AUTOFILL ASSEMBLY 6” AND 8”	77
DRAWBAR ASSEMBLY	79

Introduction

Thank you for purchasing a *Giltrap* product. *Giltrap Engineering Ltd* has enjoyed a long-standing success with their machinery. We would like you to enjoy the benefits of owning a *Giltrap* too. By following the guidelines laid out in this book, you will ensure trouble free, low maintenance operating for years.

Giltrap Engineering Ltd is a progressive company which continually strives to satisfy your needs, so we welcome any feedback which you can provide to help us improve our products and services and to ensure that they perform to your expectations. Any constructive comments about this operator's manual are also welcome.

Your machine has been designed to perform its task efficiently and with a minimum of maintenance. This handbook provides safety guidelines, instructions, maintenance requirements and parts listings. We recommend that you read the entire handbook, before operating the machine as this will enable you to take full advantage of your new machine's considerable potential.

Delivery and Warranty

Before you begin to use your machine, please check it to make sure there is no delivery damage. If damage is evident, contact the dealer who supplied the machine so that they can make the appropriate claims.

If you have any other queries, please contact your dealer or *Giltrap Engineering Ltd* (0800 80 GILTRAP).

All *Giltrap* products are covered by a 12-month warranty on parts and labour, subject to normal use.

Please fill in the details below for future reference.

Model:

Serial No:

Delivery Date:

Dealer:

General Safety

For the safety of others and yourself, please read and follow the precautions in this operator's manual. Pay particular attention to the following safety aspects of operating machinery.

Do not ride on or allow passengers on the machine.



Always use a recognised hitch pin with a safety clip to hook trailed implements on behind the tractor.

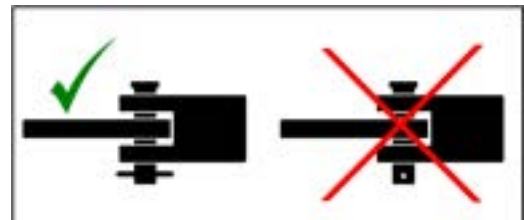

Always ensure when using a quick hitch that the locking tab has come out and is in the locked position before moving.

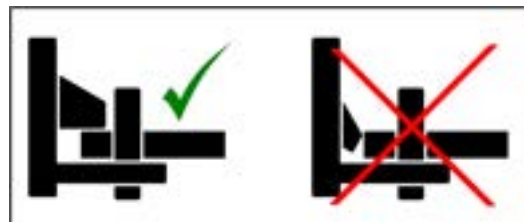

Do Not operate tractor – trailer combination outside of manufacturers recommended drawbar loading.

Carry a suitable fire extinguisher.

A fire can ignite under certain conditions, so please take the following precautions:

After running your machine for a short time, check for defective bearings. A faulty bearing can become very hot, eventually discolouring, requiring immediate replacement.

Do not allow combustible material to accumulate inside guards or around rollers and other moving parts.

If your machine becomes blocked, stop immediately and remove the obstruction.

Be careful when operating in hot or dry conditions or on extreme fire risk days.



Never operate your machine without the safety guards in place.



All chains should be properly adjusted and replaced when necessary.

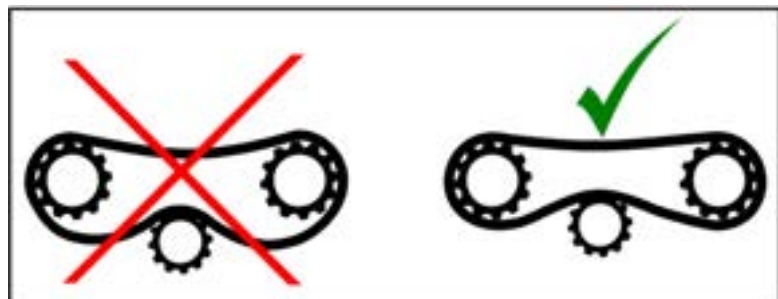

Release all hydraulic pressure from implements before commencing service work. Never look for suspected oil leaks with your hands or body - use a piece of cardboard instead. Any fluid that penetrates the skin will have to be removed immediately by a medical expert. Seek specialist advice on this type of injury.



Never attempt to unblock equipment while it is still operating. Always disengage power take-off, hydraulics and shut down engine before removing materials, checking or servicing. Failure to follow these precautions is likely to result in serious injury.



Wear proper protective clothing. Loose attire can easily be snagged by rotating machinery resulting in serious injury or death.



Driveshaft Safety



When using the implement and driveline, do not exceed the speed or power limits given by operator's manual.
Do not overload the implement or suddenly engage the PTO clutch.
Any torque limiter or clutch should be installed on the implement end of the driveline.
All rotating parts must be guarded.

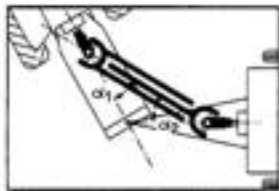

When operating, ensure that joint angles are equal.
Disengage the PTO when the angle of the joints exceeds 35°.

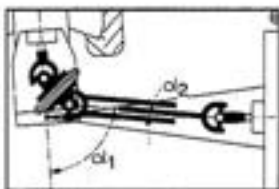

Certain type of CONSTANT VELOCITY JOINTS may operate at angles up to 70° or 80° for brief periods (e.g. during turning).

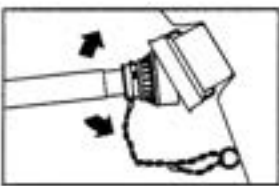

Attach the safety chains, allowing sufficient slack for the driveline during turns and operation.

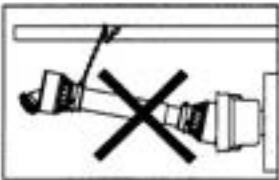

Never use the safety chains to support the driveline for storage. Always use the support on the implement.



Do not stand on the driveline. Do not step over, or go under the driveline.



Clear and grease the tractor PTO and the implement shaft before installing the driveline.

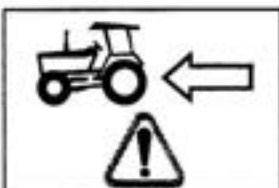

The tractor printed on the shield indicates the tractor end of the driveline. Any safety device should be installed on the implement side.



Use the implement only with the original driveline, which is compatible in length, power capacity, safety devices and shielding.
The drivelines and safety devices are designed specifically for the implement, and should be exclusively for this purpose.

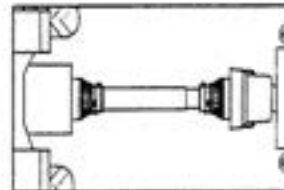

Ensure that all driveline, tractor and implement shields are functional and in place before operation. Damaged or missing parts must be replaced with original spare parts, correctly installed, before using of drivelines.



Ensure that the driveline is securely attached to the tractor and the implement before operating.



Do not wear loose clothing, jewelry, hair, or anything which could get caught in the machine. Contact with rotating parts could cause serious injury or death.

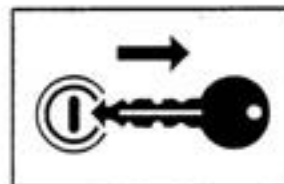

Disengage the PTO, turn off the tractor engine and remove key before approaching the implement or performing maintenance work.



When used at night or in poor visibility, illuminate the driveline operating area during installation.



Keep the driveline horizontal during handling to prevent the halves from sliding apart, which could cause injury or damage the shielding.

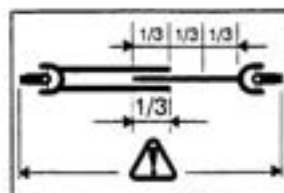

Keep the profiles overlapped as much as possible during transport and operation. Telescoping tubes must overlap by at least 1/3 of their length during operation. Always hitch the tractor to STATIONARY MACHINERY (pumps, elevators, generators, driers, etc.), so that the telescoping tubes overlap by at least 1/3 of their length.

Pre-Service Guidelines & Settings

Prior to delivering your machine, your dealer should have completed a pre-delivery check. It is required to check the following points before using the machine for the first time.

- CHECK ALL WHEEL NUTS ARE SUFFICIENTLY TIGHT.

Wheel Nut Recommended Torque Settings

M18 Stud	200 ft/lbs or 270Nm
M20 Stud	280 ft/lbs or 380Nm
M22 Stud	330 ft/lbs or 450Nm



- CHECK ALL TYRE PRESSURES ARE CORRECT.

Recommended Tyre Pressures

11.5/80-15.3	58psi	4.0 bar
400/60-15.5	50psi	3.5 bar
15.0/70-18	45psi	3.1 bar
400/55-22.5	46psi	3.2 bar
500/45-22.5	35psi	2.4 bar
500/60-22.5	35psi	2.4 bar
560/45R22.5	58psi	4.0 bar
560/60R22.5	58psi	4.0 bar
650/55R26.5	58psi	4.0 bar



- CHECK ALL AXLE MOUNTING BOLTS AND NUTS ARE SUFFICIENTLY TIGHT.

Axle Mounting Bolt Recommended Torque Settings

M16	180 ft/lbs or 245Nm
M20	355 ft/lbs or 480Nm



- THERE ARE SEVERAL GREASE POINTS on all Giltrap trailers. Check the yellow label on the side of your machine to see how many grease points there are. You should fully grease everything before running it for the first time. See page 10 for greasing and lubrication details.
- CHECK AND RETIGHTEN WHEEL NUTS AFTER:
 - First use
 - First laden journey
 - The first 50 hours of use and every 50 hours thereafter

Spreading Options

(A) Standard Spreading Plate

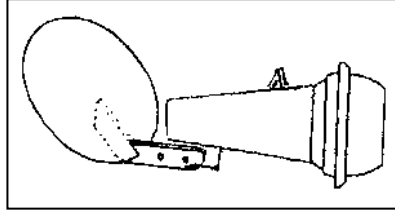

(B) Inverted Spreading Plate

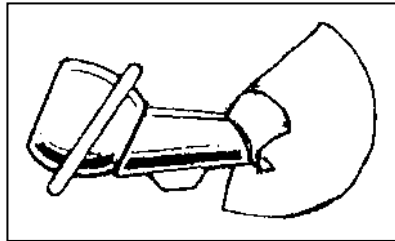

(C) Side Discharge Nozzle

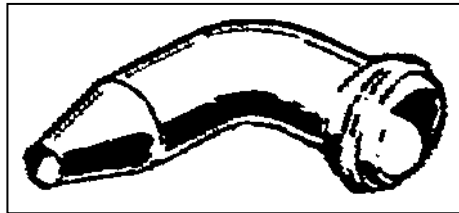

Instructions:

Two manholes are supplied on larger tanks that have a baffle to control surge. Access to the front section is through a manhole placed at the front top of the tank, and access to the rear section by manhole at the rear lower end plate. These manholes enable easy cleaning of the inside of the tank by simply removing 2 nuts on either cover and swinging the manhole clear by the hinges. Sediment or any other foreign material that may hinder the proper working of the machine is easily cleared.

Care should be taken when climbing into a tank as gases from the effluent could render a person unconscious or even kill. Another person should be in attendance.

Special Note:

Extreme care should be exercised at all times in the vicinity of the rear of the machine. Even when the machine is not running or in use, it may be holding pressure or vacuum. Either could be most dangerous if a gate valve is suddenly opened.

General Operating Instructions

1. Connect loading hose to inlet.
2. Set vacuum pump to "V" (vacuum) setting.
3. Engage PTO and set at 300-400 rpm.
4. Open tap at inlet.
5. Check to ensure there is vacuum.
6. Check oilers are operating (30-50 drops per min).
7. Watch sight tubing for filling and turn off tap immediately liquid reaches top of tube. Disconnect loading hose.
8. Turn off PTO and set vacuum to "P" (pressure).
9. Travel to unloading area.
10. Engage PTO and set at 400-500 rpm.
11. Check tank pressure.
12. Engage tractor in forward gear. Operate hydraulic unloading valve to discharge while driving at appropriate speed to spread.

Vacuum

Do not exceed bar 0.8 on gauge.

Pressure

Do not exceed bar 0.5 or cm/hg 40.

It is not necessary to use 540 rpm when loading. 300 rpm on PTO will maintain the necessary vacuum.

The pump will not generate more vacuum with more PTO rpm so will not fill any quicker.

IMPORTANT

It is vital to ensure all nuts and bolts are kept tight and should be checked regularly, especially when the machine is new. All nuts and bolts should be tightened after a week of use. Due to working conditions machines shake and vibrate which may cause loosening of some bolts. Failure to keep bolts tight may void certain warranty conditions.

Vacuum Pump Instructions & Maintenance

1.0 - Starting

1.1 Transmission

The power take-off (PTO) on the BATTIONI PAGANI MEC and SE Series vacuum pumps are normally driven by PTO shaft. The maximum angle of the PTO shaft is 15°. This angle must not be exceeded unless using a wide angle joint at the tractor end. Check that the drive shaft has sufficient overlap (1/3 length) when extended and will not bind when compressed.

Note: The wide angle should be installed at the tractor end.

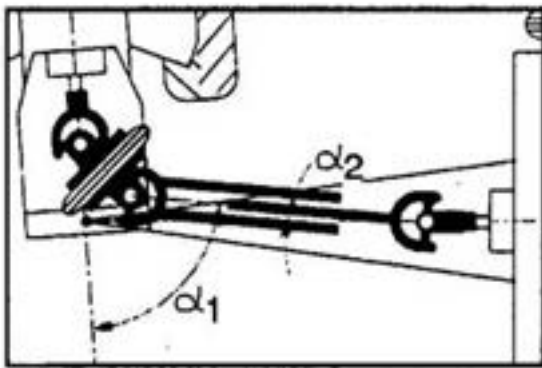

Figure 1

1.2 Rotation direction

Before starting the Vacuum Pump make sure that the power take-off (PTO) shaft turns freely and that the rotation direction is the same of that stated by the arrow. The standard rotation directions for MEC and SE series vacuum pumps are left hand (anti-clockwise).

Do not for any reason change the direction of rotation as it could damage some components or the pump itself.

1.3 Operating Speed (RPM)

Vacuum pumps with gearbox overdrive (MEC-M series) are capable of running at 600 rpm but it is recommended to use 400 PTO rpm during normal work.

Vacuum pumps with direct drive (SE-D series) are capable of running at 1000 rpm but it is recommended to use approx 800 PTO rpm during normal work.

For the first 50 working hours (running-in period), lower these values by 25-30%.

High operating speed means higher operating temperature. Run slower if possible.

1.4 Lubrication

Force feed and automatic are the two different kinds of lubrication.

The force feed system will provide lubrication in either suction or in compression by a gear pump on the back and driven by the rotor shaft. The gear pump sucks the oil from the reservoir and sends it to the metering cock which is manually regulated. Excessive oil is returned to the reservoir.

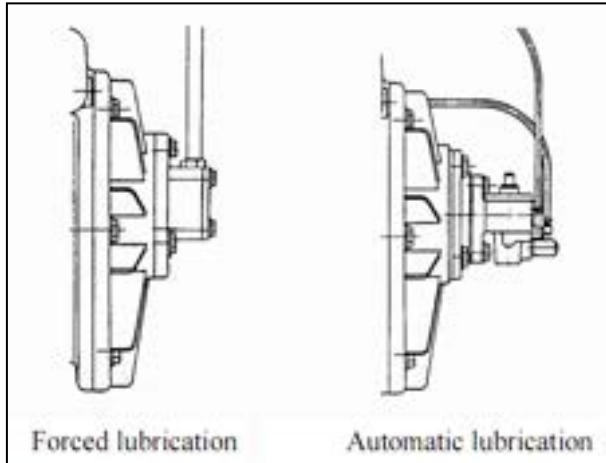

The automatic system will provide lubrication in either suction or in compression by a metering piston pump, with an adjustable delivery capacity on the back of the pump and driven by the rotor. The oil is directly injected into the vacuum pump, eliminating the manual adjustment and obtaining a great saving of oil.

2.0 - Operation

2.1 Lubrication

Before starting, ensure that the vacuum pump is filled with oil, and that the gearbox and drive oil level is showing at the sight glass indicator.

Note that the vacuum pump oil level dipstick mark (Fig.2) indicates the minimum oil level.

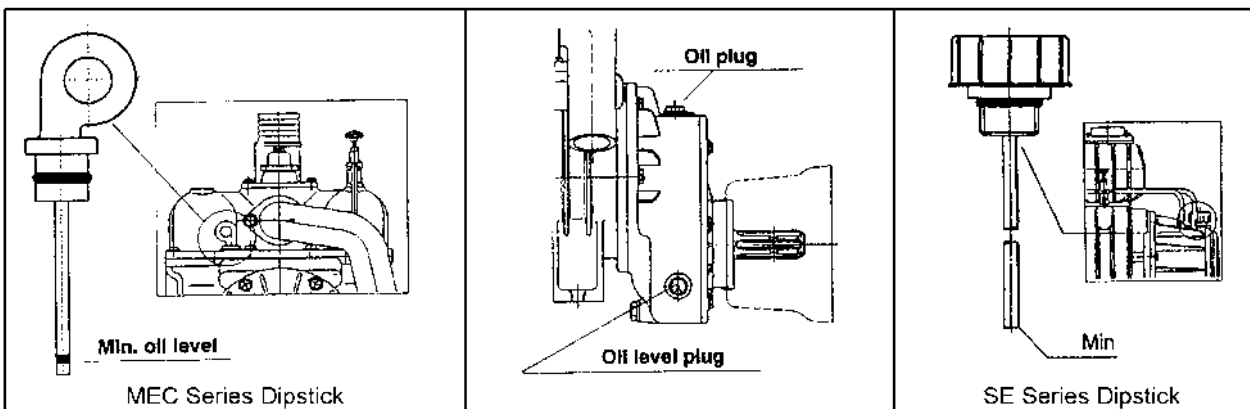

Figure 2-1.

Figure 2-2.

Figure 2-3.

Whenever checking oil levels (Fig. 2), make sure it is carried out while machine is on level ground.

The oil reservoir capacity is stated on the following table:

Pump Model	MEC 4000	MEC 6500	MEC 8000	SE 12000
Capacity - Litres	1.5	3.1	3.8	3.7

Figure 3.

2.2 Oil to use

Reservoir: Vacuum Pump Oil.

Gearbox: EP90.

Do not use hydraulic oil or cleaning oil for lubrication. Ecological oil can be used but with the same specifications of the mineral oil suggested.

Comparative types of oil are listed in the following table:

Location	Summer	Winter
In oil reservoir	Mineral oil ISO VG 100 or Mineral oil SAE 30W	Mineral oil ISO VG 46-68 or Mineral oil SAE 20W
In gearbox	Mineral oil ISO VG 460 or EP90	

Figure 4.

2.3 Oil quantity for lubrication

The correct amount of oil is metered to the pump as shown in the following table:

MEC 4000	MEC 6500 - 8000	SE12000
25-30 drops/min.	40-50 drops/min.	35-45 drops/min.

Figure 5.

These quantities are valid for either force feed or automatic lubrication (factory set).

When necessary, add only new and clean oil to the reservoir.

The gearbox oil should be changed after 100 hours work - then every 300 hours thereafter.

2.4 Oil lubrication regulation

With force feed lubrication, the oil flow is regulated by means of a hand turned knob (A), having first loosened the locking nut (B), as shown in Figure 6-1 & 6-2.

With automatic lubrication, the oil flow is set at the factory, but if necessary can be altered by the following procedure. Remove cover (B) (Figure 6-3). Loosen lock nut (C) and adjust screw (A) to obtain correct oiling rate. Tighten lock nut and replace cover.

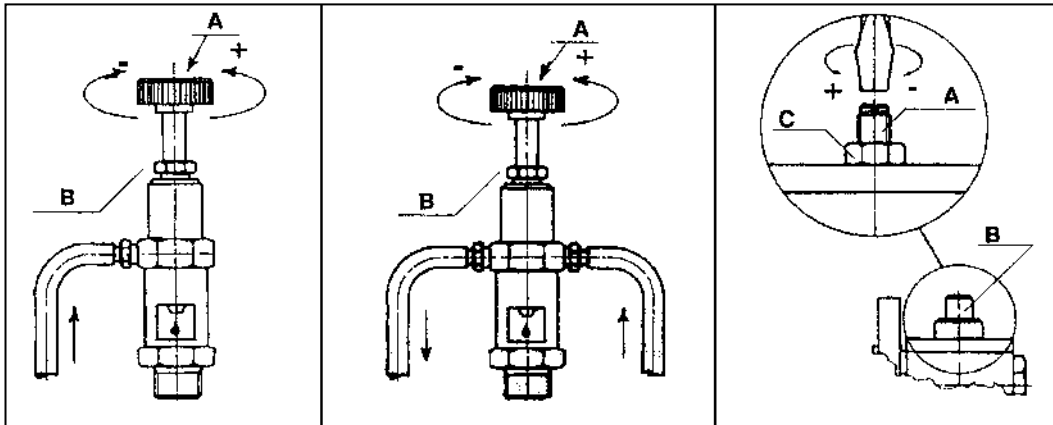

Figure 6-1.

Figure 6-2.

Figure 6-3.

2.5 Overflow valves

Avoid getting liquid into the vacuum pump as this causes "water hammer" which is responsible for the blade breakage and consequently rotor damage.

It is necessary to fit on the system a relief valve (A) and a check moisture trap (B) between the vacuum pump and the tank (Figure 7-1).

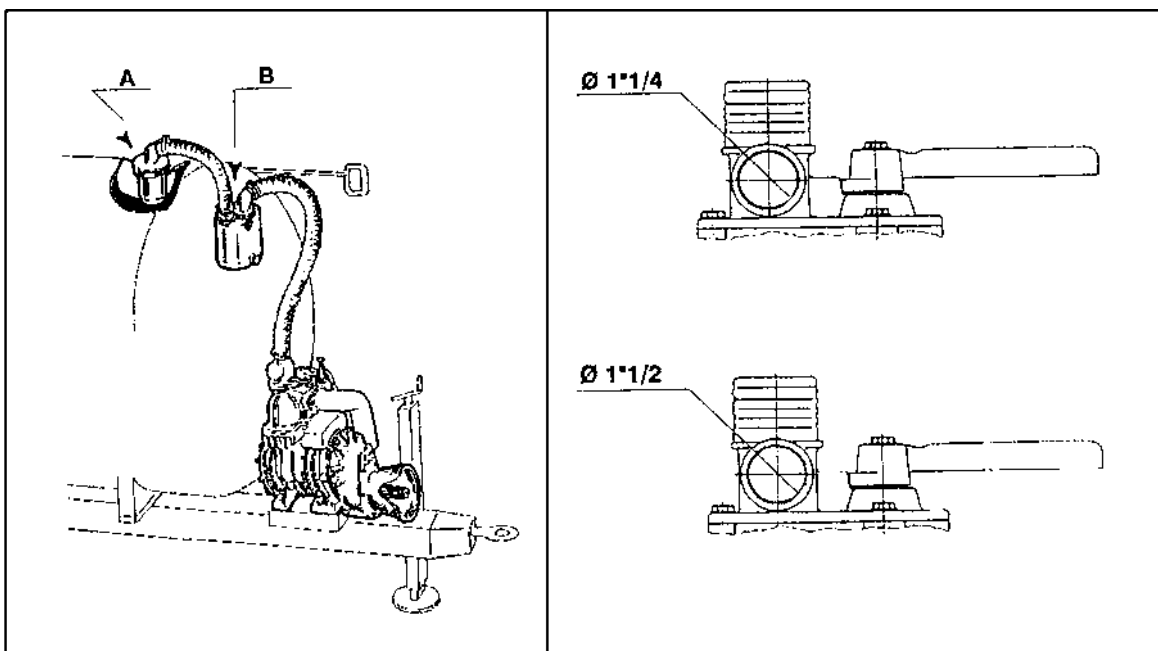

Figure 7-1.

Figure 7-2.

2.6 Pressure and Vacuum Control Valves

Pressure: The maximum operating pressure allowed is (0.8 Bar or Cm/Hg 60).

Vacuum: The maximum operating pressure allowed is (0.8 Bar or Cm/Hg 60).

Excess vacuum can cause the bore to become oval, waving of the body or blade breakage.

2.8 Washing

If effluent gets into the vacuum pump, it is necessary to immediately wash the pump internally by selecting the pressure mode and to suck a minimum of 2 litres of diesel through the intake elbow.

The same procedure should be carried out if the pump has been out of operation for a long period.

If the pump is not to be used for a long period, disconnect the suction and delivery pipes and hermetically close the manifold, as gas that develops inside the tank would pass into the vacuum pump and cause rust inside the body. This can in turn cause blade failure.

2.9 Temperature

Excessive high temperatures in the vacuum pump can damage some components and can also affect the efficiency.

For this reason, the maximum recommended temperature should be 90-95 degrees centigrade. Discolouration of paint on the pump body indicates excessive heat.

2.10 Running Time

The maximum continuous running time should be not over 6-8 minutes.

A longer running time without interruption can cause overheating and also damage the blades.

If the running time is extended due to the density of material, you should try to thin the product you are collecting.

3.0 - Maintenance

3.1 Valves

Check periodically that the safety valves on the tank are in perfect working order.

3.2 Blades

Check blade wear regularly and replace the complete set when the height is reduced (About 10-15% of the original height).

PUMP	No. of Blades	Size
MEC 4000	7	300 x 41 x 6.3
MEC 6500	7	370 x 46.5 x 6.3
MEC 8000	7	450 x 46.5 x 6.3
SE 12000	6	400 x 70 x 7.5

Figure 8.

Overheating causes blisters to develop on the blades surface which increases the thickness and blocks the free outlet from the rotor slots.

With lack of lubrication blades are completely dry as well as the pump interior. Their brittleness increases and can cause blade breakage.

Breakage can also be caused by effluent inside the pump or excessive pressure.

Excessive vacuum causes the blades to beat against the body, damaging the external part of blades and distorting the pump bore.

3.3 Storage

When the vacuum pump isn't used for a long period, it is suggested to operate as stated in chapter 2.8 – 'Washing'.

3.4 Table of Periodical Maintenance

Maintenance	Procedure	Frequency
Check oil circulation	Inspect the level sight glasses	Always, when you use it
Check the oil level in the tank	Use dipstick	Once a week
Check the valves are working	Depress valve	Once a week
Lubricate the input shaft spline	Oil with brush or spray	Once a month
Wash and clean valves	Remove valves	Once a month
Check overflow valves are working correctly	Remove valves	Once a month
Check the blades for wear	Remove threaded plug	Every 600 hours of work
Wash oil tank	Remove tank	Once a year
Wash pump body internally	Put in oil and diesel	Whenever effluent enters the pump or when pump doesn't work for a long period
Wash lubrication pump	Use a brush and compressed air	Once a year

Figure 9.

4.0 - Technical

4.1 Blade Inspection

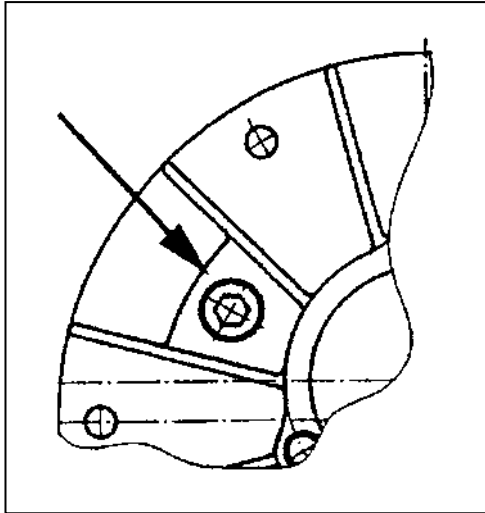

Figure 10.

To check the state of wear of the blades in the pump, proceed as follows:

- Remove the threaded inspection plug.
- Turn the rotor until a blade is aligned with the inspection hole.
- Measure the distance between the external surface of the rotor and the external side of the blade.
- If this distance is greater than 10-15% of the original height of the blade (Figure 8), replace the complete set of blades.

IMPORTANT: Before inserting the new blades, carefully check their size and, if necessary, shorten them until they are the same length as the rotor.

4.2 Honing the Pump Body

In exceptional cases extra maintenance may be carried out on the pump body to hone the internal bore. This operation is possible only when there are small dips or small undulations (less than 0.5mm on the radius) inside the pump body. When the pump body is honed, the performance of the pump is slightly reduced. To carry out this operation, follow the instructions given below:

1. First take the pump off its support
2. Remove the back and front of the pump
- 3.hone the lining of the cylinder removing no more than a 0.5mm thickness of material on the radius.
4. Re-assemble pump in the reverse order.

Vacuum Pump Specifications – MEC/M Series

		MEC 1000/M	MEC 1600/M	MEC 2000/M	MEC 3000/M	MEC 4000/M	MEC 5000/M	MEC 6500/M	MEC 8000/M
MAX CAPACITY	L/MIN	1260	1980	2750	3600	4350	6150	7000	8100
MAX SPEED	R.P.M.	600	600	600	600	600	600	600	600
MAX OPERATING PRESSURE	BAR	1,5	1,5	1,5	1,5	1,5	1,5	1,5	1,5
MAX VACUUM	BAR	-0,88	-0,89	-0,91	-0,92	-0,94	-0,94	-0,94	-0,95
ABSORBED POWER FOR 1.5 BAR PRESSURE	KW	7,5	8,5	10	14	16	21	24	27
ABSORBED POWER FOR MAX VACUUM	KW	4	4,5	5,5	7	9	11	12,5	16
SPLINED SHAFT DIN 9611	∅	1"3/8	1"3/8	1"3/8	1"3/8	1"3/8	1"3/8	1"3/8	1"3/8
VALVE HOLE	∅	—	—	1"1/4 ^{Opt}	1"1/4 ^{Opt}	1"1/4 ^{Opt}	1"1/2 ^{Opt}	1"1/2 ^{Opt}	1"1/2 ^{Opt}
NET WEIGHT	KG	40	48	75	86	102	131	146	162

OPTIONS: FORCE FEED LUBRICATION - AUTOMATIC LUBRICATION - DOUBLE OUTLET - SIDE OUTLETS - WITHOUT MANIFOLD WITH COVER - SPECIAL VANES

(See catalogue N° 882)

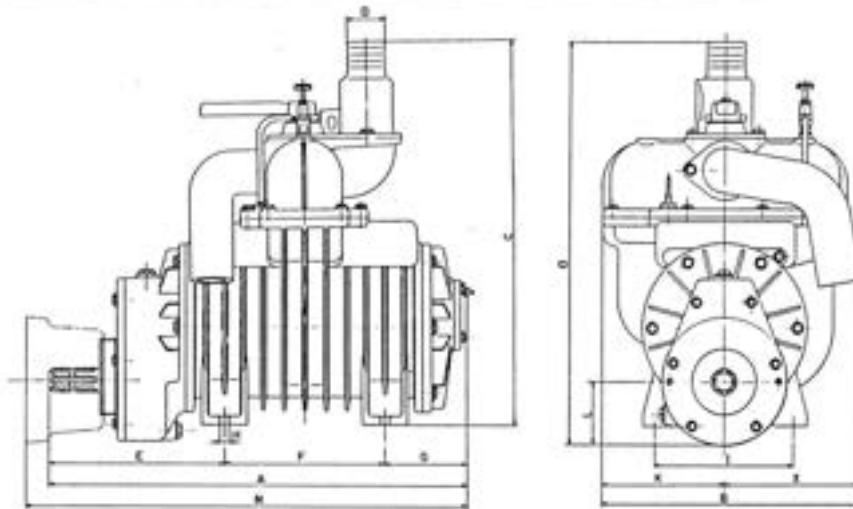

Model	A	B	C	D	D*	E	F	G	H	I	L	N	O	K	X
MEC 1000/M	356	263	362	27	1"-45	211	73	72	11	175	73	395	410	117	146
MEC 1600/M	427	263	362	45	1"-27	205	150	72	11	175	73	465	410	117	146
MEC 2000/M	439	342	479	45	60-76	191	172	76	15	227	95	473	557	164	178
MEC 3000/M	506	342	479	60	45-76	240	172	94	15	227	95	540	557	164	178
MEC 4000/M	572	342	479	60	45-76	264	189	119	15	227	95	606	557	164	178
MEC 5000/M	588	410	597	60	76-80	304	189	95	15	227	95	623	637	195	215
MEC 6500/M	658	410	597	60	76-80	276	252	130	15	227	95	693	637	195	215
MEC 8000/M	738	410	597	80	60-76	316	252	170	15	227	95	773	637	195	215

D* = Dimensions on request

Approximate data and measures

Vacuum Pump Specifications –SE/D Series

		SE 6500/D	SE 8000/D	SE 10000/D	SE 12000/D				
MAX CAPACITY	L/MIN	7000	8100	10600	12800				
MAX SPEED	R.P.M.	1400	1400	1400	1400				
MAX OPERATING PRESSURE	BAR	1,5	1,5	1,5	1,5				
MAX VACUUM	BAR	-0,93	-0,94	-0,95	-0,95				
ABSORBED POWER FOR 1.5 BAR PRESSURE	KW	21	23	31	35				
ABSORBED POWER FOR MAX VACUUM	KW	13	14	18	20				
SPLINED SHAFT DIN 9611	∅	1"3/4	1"3/4	1"3/4	1"3/4				
VALVE HOLE	∅	1"1/2 Gas	1"1/2 Gas	2" Gas	2" Gas				
NET WEIGHT	KG	145	159	206	222				

OPTIONS: AUTOMATIC LUBRICATION - DOUBLE OUTLET - SPECIAL VANES - ANTICLOCKWISE ROTATION

(See catalogue N° 882)

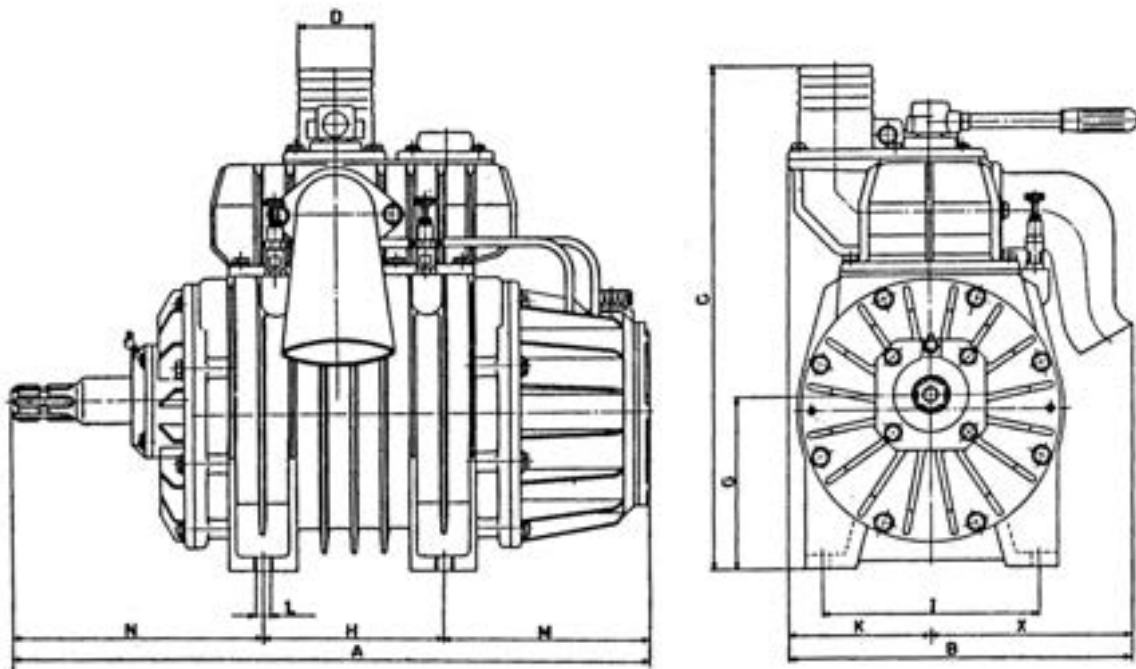

Model	A	B	C	D	D*	G	H	I	L	M	N	K	X		
SE 6500/D	706	361	534	60	80	182	192	230	16	191	245	153	208		
SE 8000/D	756	361	534	80	60	182	192	230	16	216	270	153	208		
SE 10000/D	710	422	622	80	76-100	196	245	250	16	204	286	185	237		
SE 12000/D	760	422	622	100	76-80	196	245	250	16	229	311	185	237		

D* = Dimensions on request

Approximate data and measures

Vacuum Pump Troubleshooting

Problem	Cause	Remedy
Little vacuum or pressure	Blades are worn	Replace blades
	Some blades are jammed in the rotor	Disassemble pump, clean and wash rotor, blades and body
	System leakage	Eliminate leakages using soapy water
	Corrugated cylinder	Smooth or replace the body
	Reversing gear/handle incorrectly positioned	Remove reversing gear/handle and position correctly
	Pump is rotating in wrong direction	Reverse direction of rotation
	Blades protrude from the rotor slots anomalously	Disassemble pump, clean and wash rotor, blades and body
	Rubber ball closes overflow valve	Increase passage of air inside valve
	Suction hose has delaminated	Replace hose
	Relief valves are leaking	Re-adjust spring tension
Overheating	Flange assembly too tight	Add a gasket to the back flange
	Excessive pressure	Reduce pressure
	Excessive rate of revs	Reduce rate of revs
	Excessive operating time	Reduce operating time
	Blades too long	Trim blades to correct size
	Lack of lubrication	Check oil level in tank, oil pump operation, setting of oil tap
Rotor blades beating against bore surface	Rate of revs too low	Increase rate of revs
	Vacuum too high	Reduce vacuum
Slurry comes out of discharge elbow.	Overflow valve malfunction	Check valves
Smoke comes out of discharge elbow.	Excessive lubrication	Adjust lubrication
No circulation of lubrication oil (for pumps with automatic lubrication).	Air intake at pipe fittings	Replace pipe fittings
	Air in oil pump chamber	Insert lubrication tube correctly
	Oil level in reservoir too low	Fill with oil
PTO does not rotate/PTO noisy	Broken blade	Replace blade (check if rotor pin is bent)
	Foreign body in the pump	Remove foreign body
	Broken rotor	Replace rotor
	Broken gearbox	Replace broken parts. Check PTO driveshaft for lubrication and/or worn tubes causing lockup
	Broken PTO shaft joint	Shaft is too long. Shorten shaft
	PTO shaft incorrectly installed. PTO shaft too long or short.	Repair or replace. Ensure wide angle joint is nearest to tractor.
Oil discharge from oil tank	Faulty gasket	Check/repair/replace gasket

Auto Fill Operation

The slurry tank will have two hoses pressure and return for the Auto fill system, and one hose for the rear discharge gate valve. Note: There may be other hydraulic hoses depending on the options fitted.

Using slurry tank auto full system:

- Setup pod near pond with hoses in pond, see photo.
- Lower auto fill arm when driving near the pod for better guidance.
- Lower the arm onto pod, Pump is now in Vacuum position.
- Engage PTO, see Operating instruction notes.
- When tank is full, shut off PTO.
- Lift arm about 50mm off tyre to let fluid return down pod pipe.
- Lift arm fully.
- Drive to location.
- Engage PTO (speed) Note Auto fill arm is in the up position which changes the pump to pressures the tank.
- Use separate lever to open discharge gate at rear.





Note: for filling tank with manual vale (not auto fill system) see sticker on valve block.

Hydraulic Suspension Operation and Information

Using Hydraulic Suspension

Pressurise the LOWER line until the machine is on the desired angle. Close the red valve (clock wise) to lock this pressure setting. The hoses can then be removed from the tractor.

Note: If the cylinder is fully extended, the hydraulic suspension will not operate as tractor hydraulic pressure will have overcome the accumulator pressure.

For best performance, set drawbar to mid-height position.

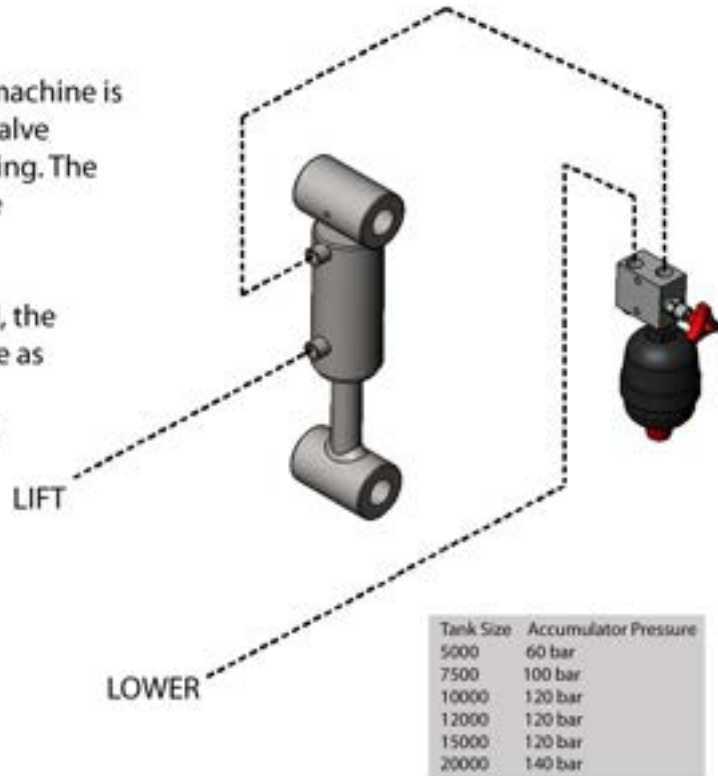

Maintenance of Stock & Consignment Slurry Tanks

The slurry tank pump is subject to corrosion from condensation and after-use fluids being left in the system.

Prevention of the above is achieved by passing diesel oil through the pump on a regular basis.

Instructions

- Open the side valve at the rear of the tank (this avoids pressurising the tank).
- Put pump lever in pressure position (P).
- Run PTO at an 'idling' speed.
- Place an open container of minimum 2.5 litres diesel oil under the pump exhaust pipe.
- Immediately when oil is gone, put pump lever in mid-position (neutral) position and stop PTO.

It would be appreciated if you were not already following the above procedure, that you implement it as soon as possible.

Tank Assembly Fittings

5000 & 7500

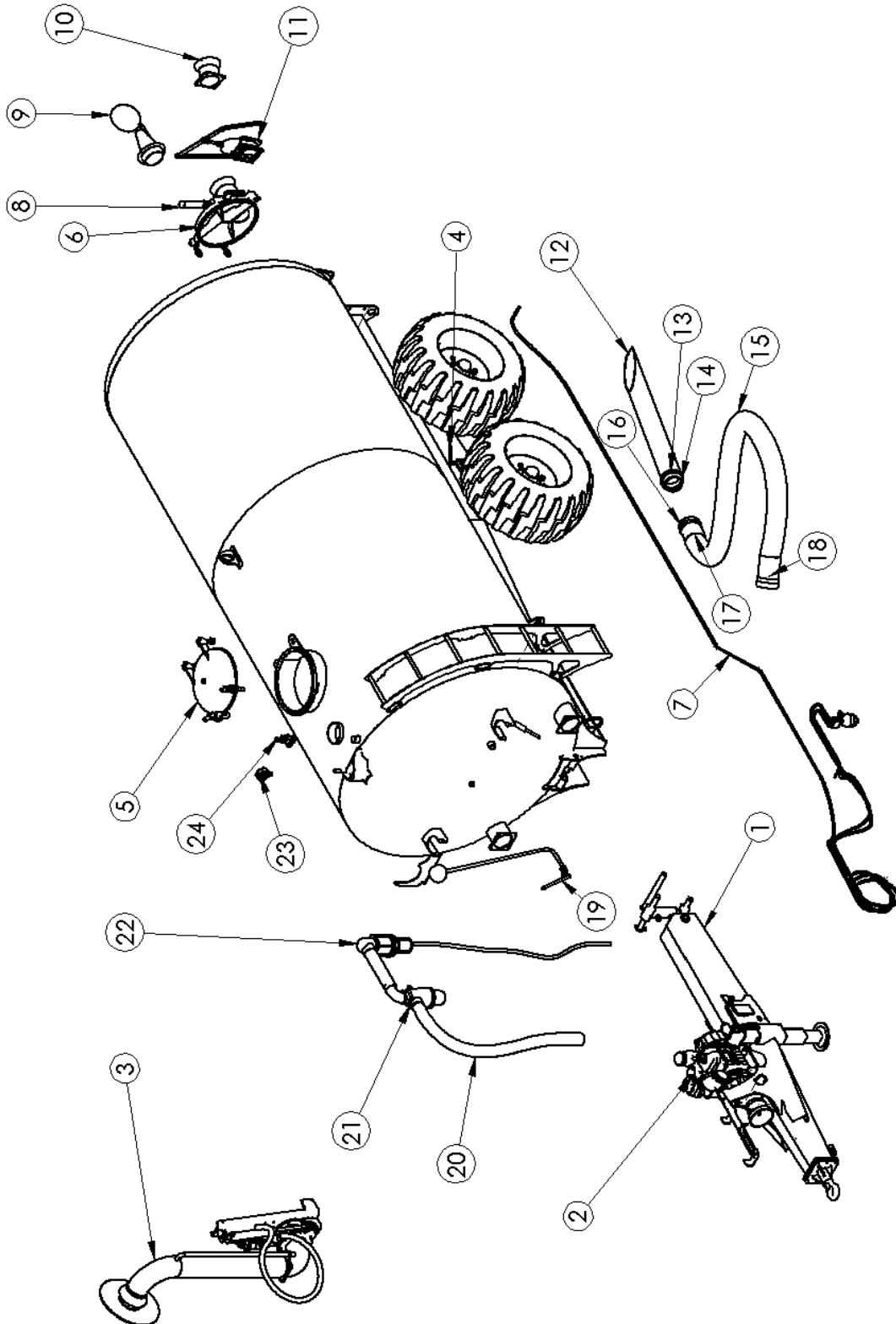

Tank Assembly Fittings – 5000 & 7500

Item	Part Number	Description	Size	M5000	M7500
1	Go to pg 79	Draw bar assembly			
2	VP-MEC6500/A	MEC 6500 Vacuum Pump	80mm	1	-
2	VP-MEC8000/A	MEC 8000 Vacuum Pump	80mm	-	1
3	Go to pg 77	Autofill assembly			
4	Go to pg 59-69	Axle assembly			
5	Go to pg 34	Top hatch assembly			
6	Go to pg 34	Rear hatch assembly			
7	Go to pg 72	hydraulic assembly			
8	VP-ART51/G	Gate Valve Jack with gas return	150mm	1	1
8	VP-ART51/G	Gate Valve Jack with gas return	150mm	1	1
9	VP-517/G	Fan Diffuser with male spherical joint	150mm	1	1
10	VP-524/G	Female Spherical Joint with thread	150mm	1	1
11	VP-303/G	Stemgate Valve (Threaded / Threaded)	150mm	1	1
11	VP-311/G	Stemgate Valve (Threaded / Flange)	150mm	1	1
11	VP-304/G	Stemgate Valve (Flange / Flange)	150mm	1	1
12	VP-507/G	Suction Pipe with hose adaptor	150mm	1	1
15	VP-402/D	Rubber Suction and Delivery Hose	80mm	2m	2m
15	VP-401/G	Rubber Suction Hose - 4m	150mm	2	2
16	VP-520/G	Female Spherical Joint with pipe fitting	150mm	2	2
17	VP-530/G	Hose Clamp	150mm	6	6
18	VP-519/G	Male spherical joint with pipe fitting	150mm	3	3
18	VP-520/G	Female Spherical Joint, pipe fitting clamps	150mm	2	2
19	VP-1001/C	Sight Glass	2"	3	3
21	VP-201/D	Check Moisture Trap	80mm	1	1
22	VP-202/D	Ball Overflow Valve	80mm	1	1
22	VP-530/D	Hose Clamp	80mm	4	4
23	VP-901/D	Vacuum Pressure Gauge	80mm	1	1
24	VP-305/B	Safety Valve	1-1/2"	1	1
Pg 31	VP-306/B	Safety Valve with hose connection	1-1/2"	1	1
Pg 31	VP-314/B	Depression Valve	1-1/2"	1	1
20	VP-402/E	Rubber Suction and Delivery Hose	2m	2m	100mm

10000, 12000 & 15000

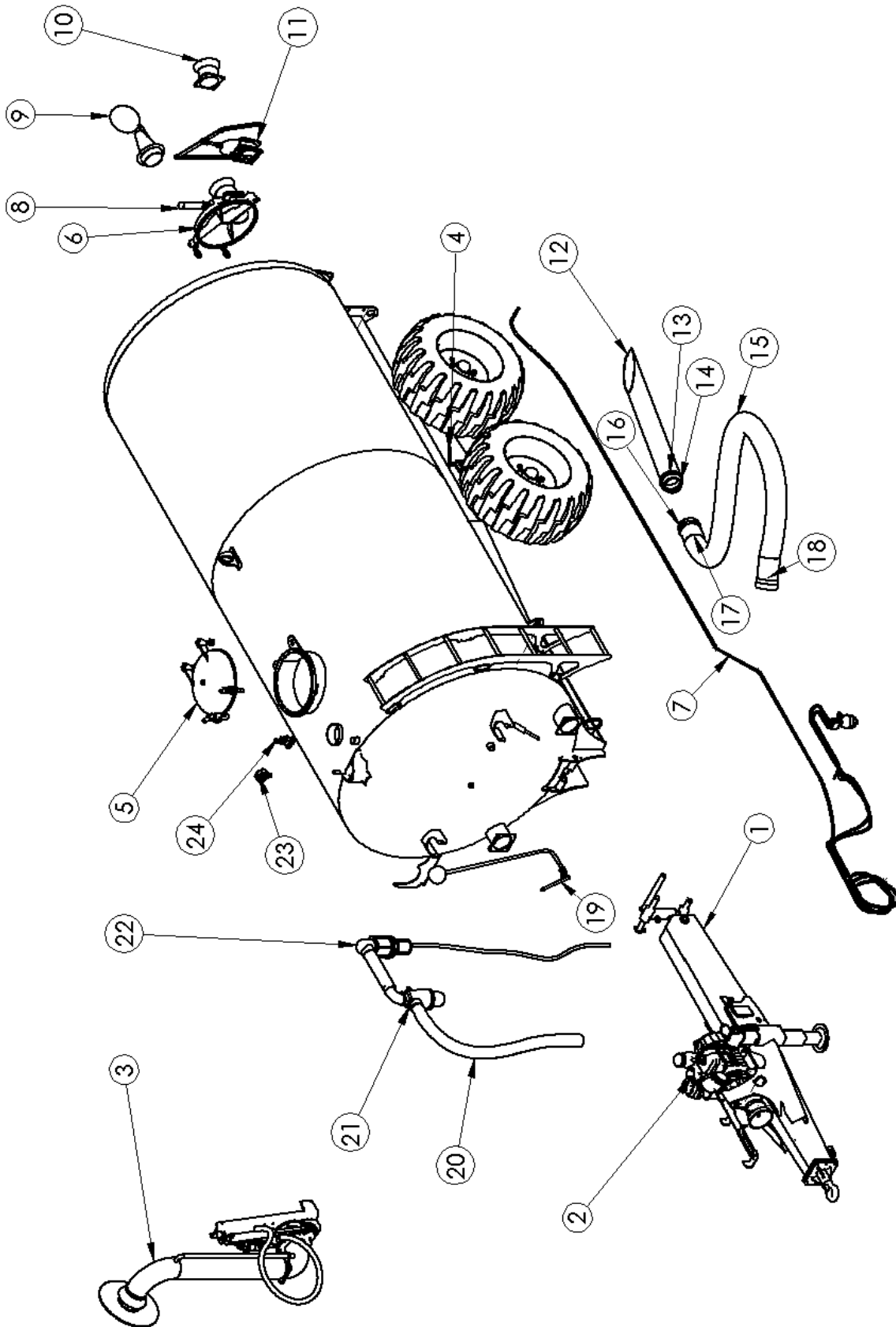

Tank Assembly Fittings – 10000, 12000 & 15000

Item	Part Number	Description	Quantity		Size
			150mm Port	200mm Port	
1	Go to pg 79	Draw bar assembly			
2	VP-STAR 72-PTG	Star 72 Vacuum Pump	1	1	100mm
3	Go to pg 77	Autofill assembly			
4	Go to pg 59-69	Axle assembly			
5	Go to pg 34	Top hatch assembly			
6	Go to pg 34	Rear hatch assembly			
7	Go to pg 72	hydraulic assembly			
8	VP-ART51/G	Gate valve ram with gas return	1		150mm
9	VP-517/G	Fan diffuser with male spherical joint	1		150mm
9	VP-517/H	Fan diffuser with male spherical joint		1	200mm
10	VP-524/G	Female spherical joint with thread	1		150mm
10	VP-524/G-1	Female spherical joint with flange	1		150mm
10	VP-524/H	Female spherical joint with thread		1	200mm
10	VP-524/H-1	Female spherical joint with flange		1	200mm
11	VP-303/G	Stemgate Valve (Threaded / Threaded)	1		150mm
11	VP-303/H	Stemgate Valve (Threaded / Threaded)		1	200mm
11	VP-311/G	Stemgate Valve (Threaded / Flange)	1		150mm
11	VP-311/H	Stemgate Valve (Threaded / Flange)		1	200mm
11	VP-304/G	Stemgate Valve (Flange / Flange)	1		150mm
11	VP-304/H	Stemgate Valve (Flange / Flange)		1	200mm
12	VP-507/G	Suction pipe with hose adaptor	1		150mm
12	VP-509/H	Suction pipe with hose adaptor		1	200mm
13	VP-521/G	Male plug	1		150mm
13	VP-521/H	Male plug		1	200mm
14	VP-519/G	Male spherical joint with pipe fitting	3		150mm
14	VP-519/H	Male spherical joint with pipe fitting		3	200mm
14	VP-520/G	Female spherical joint, pipe fitting clamps	2		150mm
14	VP-520/H	Female spherical joint, pipe fitting clamps		2	200mm
15	VP-401/G	Rubber Suction Hose - 4m	2		150mm
15	VP-401/H	Rubber Suction Hose - 4m		2	200mm
16	VP-520/G	Female spherical joint with pipe fitting	2	2	150mm
17	VP-530/D	Hose Clamp	4	4	100mm
17	VP-530/G	Hose Clamp	6		150mm
17	VP-530/H	Hose Clamp		6	200mm
18	VP-ART50/H	Gate valve ram with gas return		1	200mm
19	VP-1001/C	Sight Glass	3	3	2"
20	VP-402/E	Rubber Suction and Delivery Hose	2m	2m	100mm
21	VP-201/D	Check Moisture Trap	1	1	100mm

Item	Part Number	Description	Quantity		Size
			150mm Port	200mm Port	
22	VP-202/E	Ball Overflow Valve	1	1	100mm
23	VP-901/E	Vacuum Pressure Gauge	1	1	-
24	VP-305/B	Safety Valve	1	1	1-1/2"
Pg 31	VP-306/B	Safety Valve with hose connection	1	1	1-1/2"
Pg 31	VP-314/B	Depression Valve	1	1	1-1/2"

Slurry Tank Fittings Reference

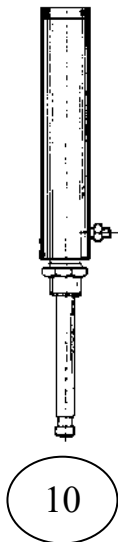
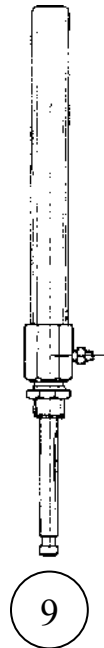
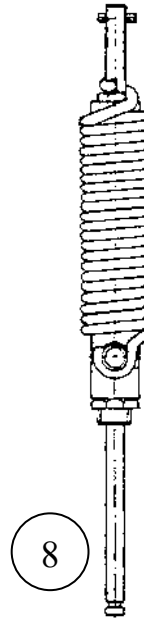
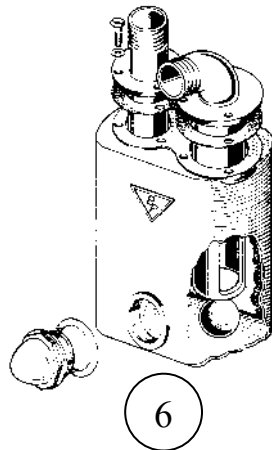
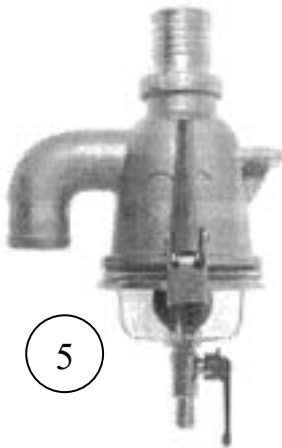
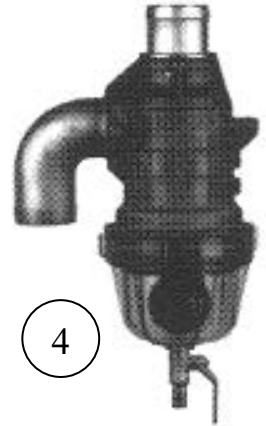
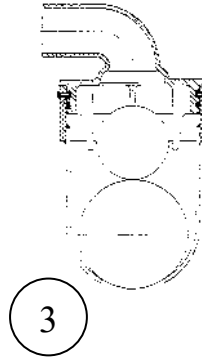
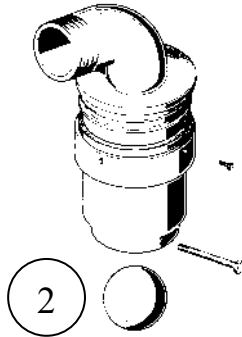

Slurry Tank Fittings Reference

Item	Part Number	Description
1	VP-202	Overflow valve with sight glass
2	VP-202	Overflow valve, cast iron body
3	VP-202	Overflow valve, aluminium/steel body
4	VP-201	Syphon valve, plastic body - 'screw on' bowl
5	VP-201	Syphon valve, aluminium body - 'clamp on' bowl
6	VP-201	Syphon valve, cast iron body (unavailable)
8	VP-ART51	Gate valve ram, spring return
9	VP-ART50	Gate valve ram, gas return
10	VP-ART50	Gate valve ram, gas return
11	VP-306	Safety Valve with hose fitting
12	VP-314	Depression Valve
13	VP-305	Safety Valve

Note: Specify size when ordering.

Rear & Top Hatch Assemblies

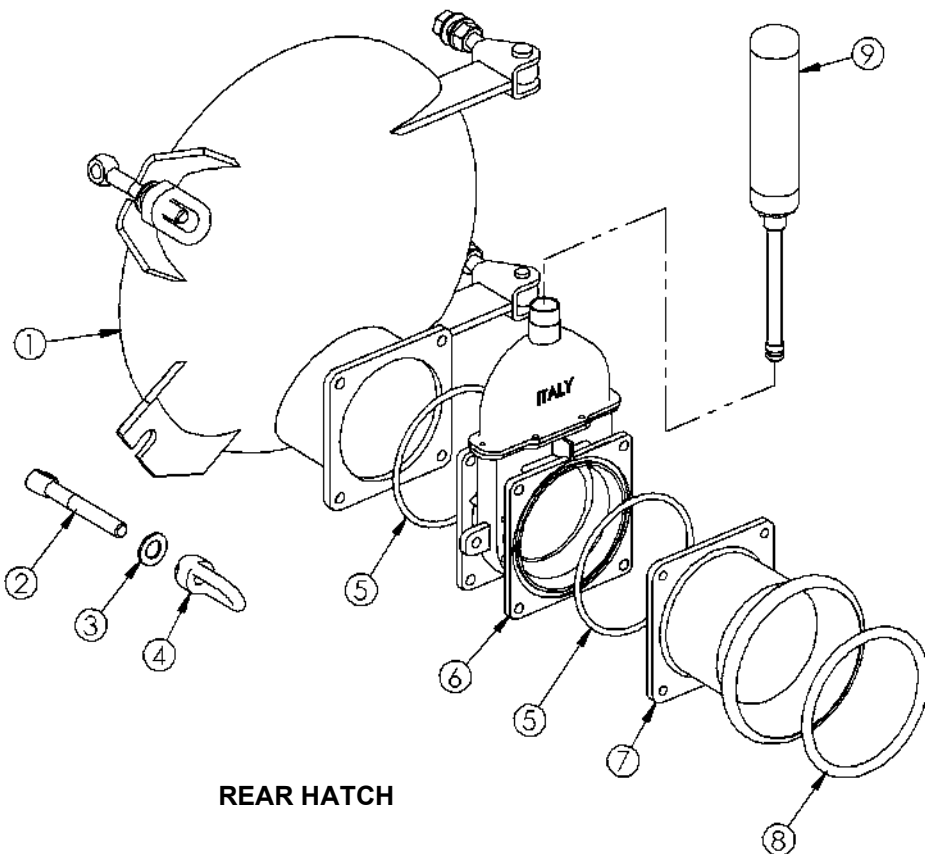
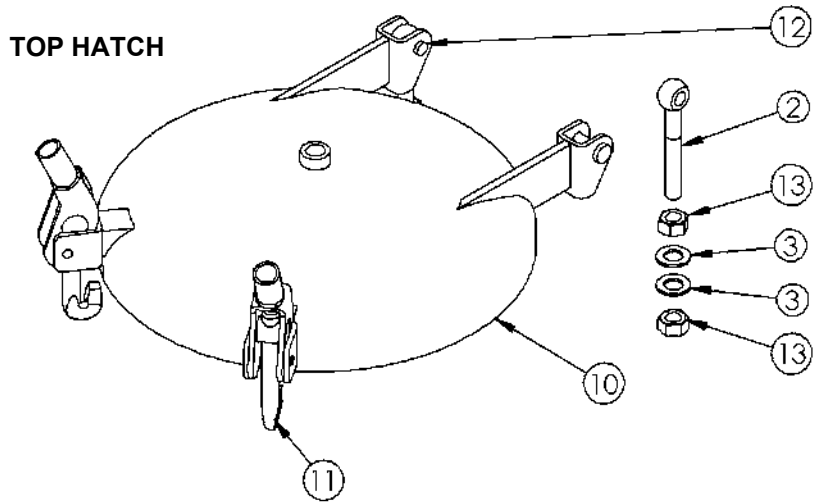

Rear & Top Hatch Assemblies

Item	Part Number	Description	Quantity Used
1	GSSMHCB	Rear Manhole Cover	1
2	GSS-02.172	Eye Bolt	4
3	WA20	Washer, Flat M20	6
4	GSS-02.174	Eye Bolt Nut	2
5	VP-529/GT	O-Ring	2
6	VP-304/G	Brass Gate Valve	1
7	VP-524/G-1	Hose Coupling Adaptor	1
8	VP-529/G	O-Ring	1
9	VP-ART51	Hydraulic Ram	1
10	GSSMHCTOP	Top Manhole Cover	1
11	GSS-02.015	Overcentre Latch	2
12	GSS-02.180	Eye Bolt Pin	2
13	N20	Nut, M20	4

Vacuum pump part break down

MEC6500/8000 Vacuum Pump with Overdrive

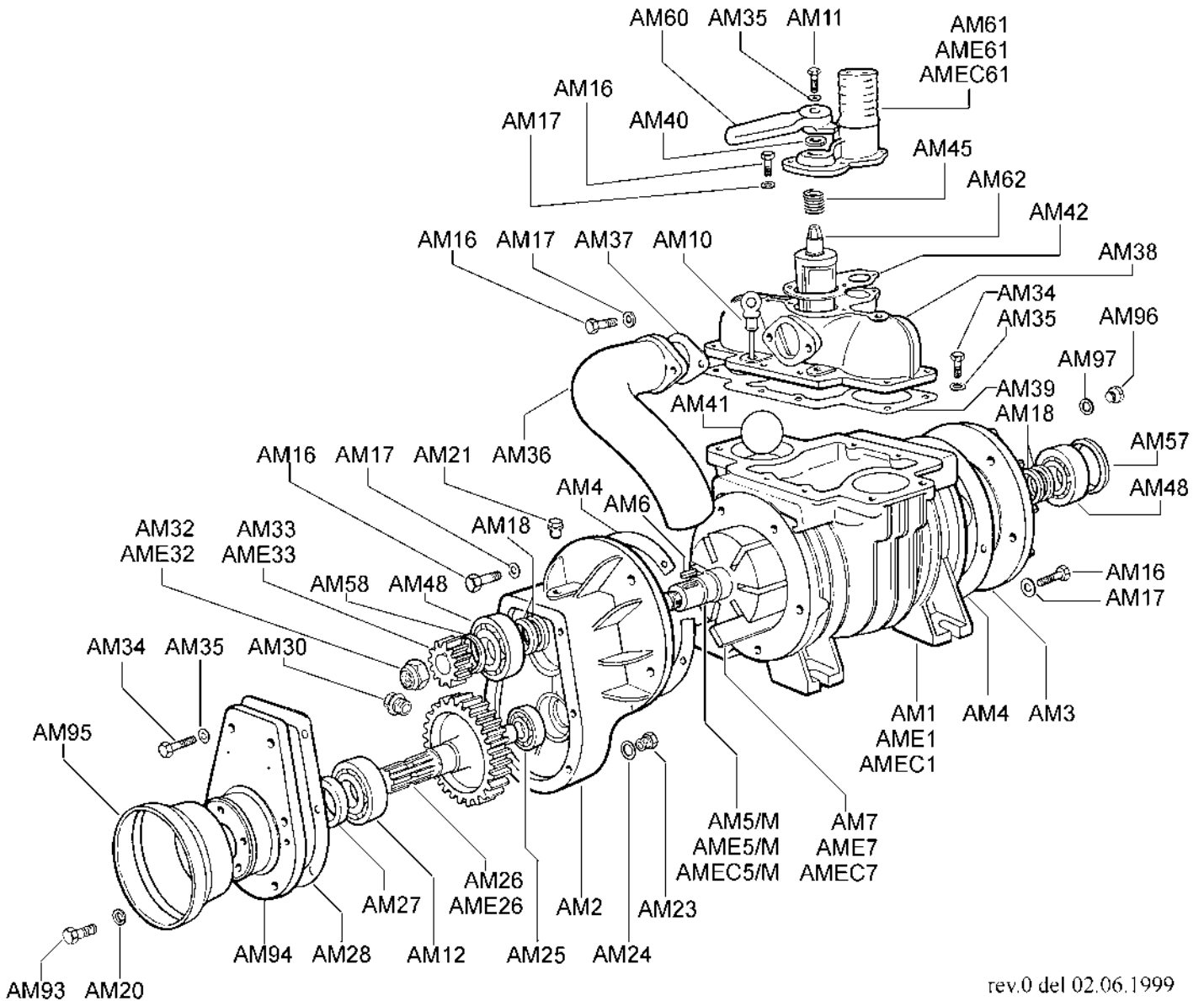

rev.0 del 02.06.1999

MEC6500/8000 Vacuum Pump with Overdrive

Item	Part #	Description	Std	Quantity
AMEC 1	4010101007	Pump body	MEC 6500	1
AME 1	4010101008	Pump body	MEC 8000	1
AM 2	4010301003	Gearbox		1
AM 3	4010401003	Back flange		1
AM 4	4030108007	Flange gasket		2
AMEC 5/M	4010220015	Rotor	MEC 6500/M	1
AME 5/M	4010220016	Rotor	MEC 8000/M	1
AM 6	5050707002	Key	6x6x25	1
AMEC 7	4070113007	Blade FII MEC 6500	370x46.5x6.3	7
AME 7	4070113008	Blade FII MEC 8000	450x46.5x6.3	7
AM 10	5060100002	Oil level rod	79mm	1
AM 11	5050107009	Screw	M8x20	1
AM 12	5012107010	Ball bearing	6307	1
AM 16	5050107020	Screw	M10x25	19
AM 17	5050207004	Flat washer	M10	19
AM 18	5030300006	Oil seal	48x62x8	4
AM 20	5050207002	Flat washer	M6	4
AM 21	5060605001	Oil fill plug	3/8" Gas	1
AM 23	5050107018	Oil discharge plug	M16x16	1
AM 24	5050202002	Aluminium washer	M10x16	1
AM 25	5012107006	Ball bearing	6304	1
AM 26	4020507002	Gear with shaft	Z 55 - M 2.5	1
AME 26	4020507003	Gear with shaft	Z 53 - M 2.5	1
AM 27	5030300005	Oil seal	35x62x10	1
AM 28	4030108006	Gearbox cover gasket		1
AM 30	5060105004	Oil level plug	3/8" Gas	1
AM 32	5050300001	Self-locking nut	M24x2	1
AME 32	5050300002	Self-locking nut	M27x2	1
AM 33	4020607002	Pinion	Z 21 - M 2.5	1
AME 33	4020607003	Pinion	Z 23 - M 2.5	1
AM 34	5050107010	Screw	M8x25	14
AM 35	5050207003	Flat washer	M8	15
AM 36	4010901003	Discharge elbow		1
AM 37	4030110003	Manifold side gasket		1
AM 38	4010501004	Manifold		1
AM 39	4030109005	Manifold gasket		1
AM 40	5030300007	Oil seal	30x40x7	1
AM 41	5060410006	Rubberball	70mm	1
AM 42	4030109006	Manifold cover gasket		1
AM 45	4012007002	Spring		1
AM 48	5012107004	Ball bearing	6208	2
AM 57	4011707010	Spacer	80x70x5	2
AM 58	4011707008	Spacer	50x40x5	1
AM 60	4010801007	Handle	II series	1
AME 61	4010601076	Manifold cover	80mm	1
AM 62	4010701012	Reversing gear		1
AM 93	5050107005	Screw	M6x16	4
AM 94	4010601115	Gearbox cover for BC guard		1
AM 95	4060505000	Shaft guard	Mod. 21902 CE	1
AM 96	5050906006	Iron plug	M16x1	2
AM 97	5050202001	Aluminium washer	M16x20	2

SE12000 Vacuum Pump

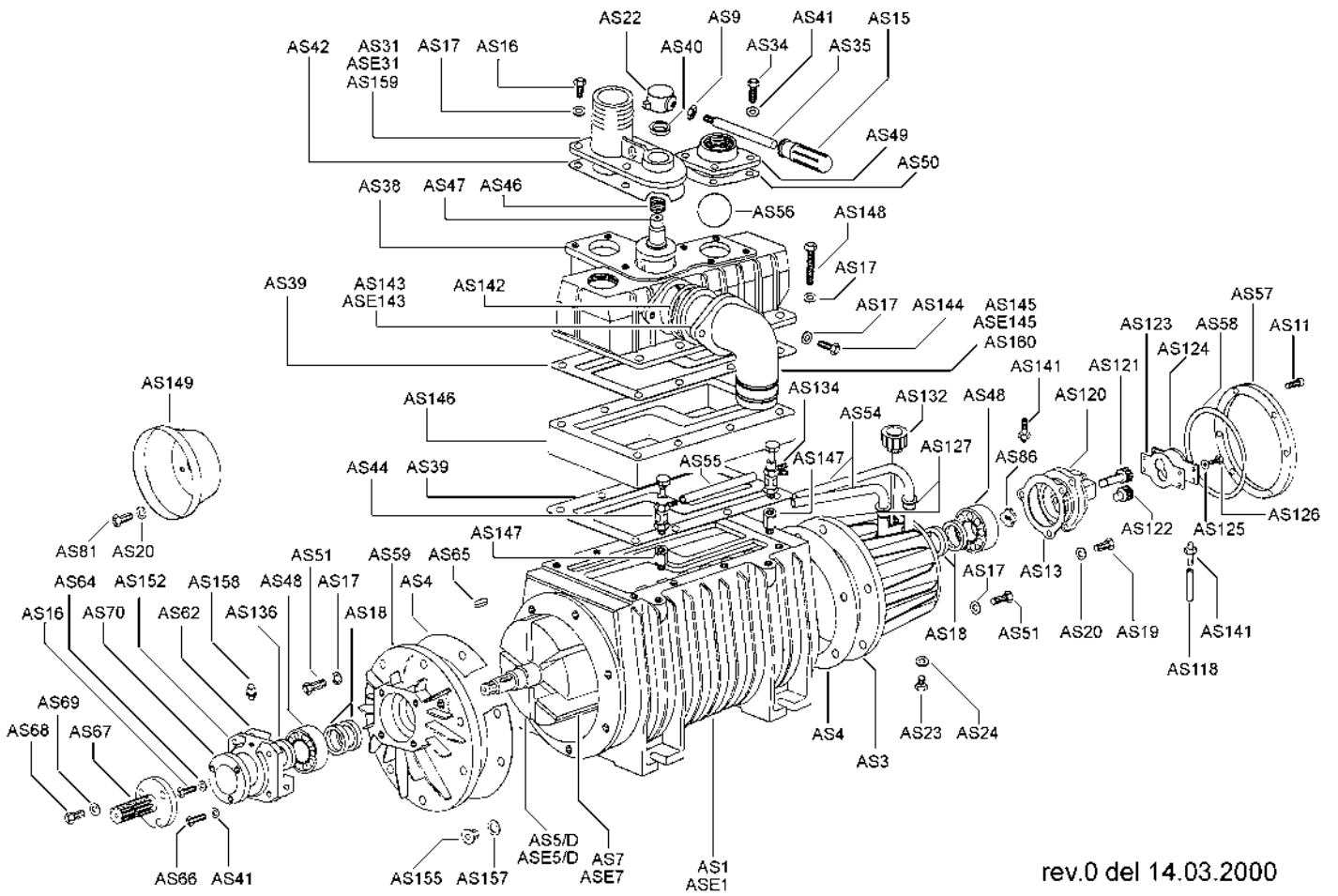

rev.0 del 14.03.2000

SE12000 Vacuum Pump

Item	Code	Description	Std	Qty
ASE 1	4010101015	Pump body		1
AS 3	4011401002	Back tank		1
AS 4	4030108017	Body gasket		2
ASE 5/D	4010220038	Rotor		1
ASE 7	4070113028	Blade RCN-G SE 12000	400x70x7.5	6
AS 9	5050307004	Nut	M12	1
AS 11	5050107008	Screw	M6x16 TCEI	6
AS 13	4030108018	Back cover gasket		1
AS 15	5060010001	Handle knob		1
AS 16	5050107020	Screw	M10x25 TE	14
AS 17	5050207004	Flat washer	10mm	26
AS 18	5030300013	Oil seal	55x68x8	4
AS 19	5050107006	Screw	M6x20 TE	3
AS 20	5050207002	Flat washer	6mm	3
AS 22	4010801005	Reverse selector		1
AS 23	5050107018	Screw	M10x16 TE	2
AS 24	5050202002	Aluminium washer	10x16	2
ASE 31	4010601037	Manifold cover	100mm	1
AS 34	5050107010	Screw	M8x25 TE	12
AS 35	4011912001	Handle pin		1
AS 38	4010501008	Manifold		1
AS 39	4030109015	Manifold gasket		1
AS 40	5030300015	Oil seal	35x50x7	1
AS 41	5050207003	Flat washer	8mm	13
AS 42	4030109016	Manifold cover gasket		1
AS 44	5040200002	Drain cock	1 way	1
AS 46	4012007004	Spring		1
AS 47	4010701008	Reversing gear		1
AS 48	5012107012	Ball bearing		2
AS 49	4010601045	Valve cover		1
AS 50	4030109017	Valve cover gasket		1
AS 51	5050107021	Screw	M10x30 TE	12
AS 56	5060410007	Rubber ball	90mm	1
AS 57	4010601040	Oil tank cover		1
AS 58	5030210003	Ring seal	OR4700	1
AS 62	4030108020	Front cover gasket	SE/D	1
AS 64	5050207011	Washer	10x50x5	1
AS 65	5050707009	Key	10x8x50	1
AS 66	5050107010	Screw	M8x25 TE	4
AS 67	4020107005	Flange with splined shaft	DIN 1-3/8" Spline	1
AS 68	5050107029	Screw	M14x30 TE	3
AS 69	5050207006	Flat washer	14mm	3

AS 70	4020107003	Coupling with drive flange		1
AS 81	5050107005	Screw	M6x16 TE	5
AS 86	4010006002	Connector joint		1
AS 118	5080110002	Rubber hose	5x10.5x120	1
AS 120	4010101011	F.F.L. oil pump body		1
AS 121	4020507007	Driving gear		1
AS 122	4020507008	Driven gear		1
AS 123	4030108030	F.F.L. oil pump cover gasket		1
AS 124	4010604001	F.F.L. oil pump cover		1
AS 125	5050207001	Flat washer	5mm	4
AS 126	5050107001	Screw	M5x12 TE	4
AS 136	5030300022	Oil seal	45x65x10	1
AS 141	5040303013	Connector	M6xl	2
AS 142	5030210008	Seal ring	OR 189	1
ASE 143	4010406015	Flange	100mm	1
AS 144	5050107054	Screw	M10x35 TE	2
ASE 145	4010901020	Revolving elbow	100mm	1
AS 146	4011707029	Manifold spacer		1
AS 147	4011707031	Cock spacer		2
AS 148	5050107023	Screw	M10x70 TE	8
AS 152	4010601125	Front cover - CE	SE/D	1
AS 155	5050906006	Iron Plug	16x1	2
AS 157	5050202007	Aluminium washer	16x20	1
AS 158	5050812001	Lubricator	M10x1	1
AS 159	4010601038	Manifold cover	76mm	1
AS 160	4010901018	Discharge elbow	76mm	1

-	VP-SED12000/GS	Gasket Set	SE 12000	1
ASE 7	VP-SED12000/BL	Blade	400x70x7.5	6
-	VP-SED12000/BLS	Blade Set	SE 12000	1

Note: Gasket set includes the following:

AS 4	4030108017	Body gasket		3
AS 13	4030108018	Back cover gasket		1
AS 28	4030108019	Gearbox cover gasket (not used with direct drive pump)		1
AS 39	4030109015	Manifold gasket		2
AS 42	4030109016	Manifold cover gasket		1
AS 50	4030109017	Valve cover gasket		1
AS 62	4030108020	Front cover gasket		1

Vacuum Pump Lubrication – SE12000

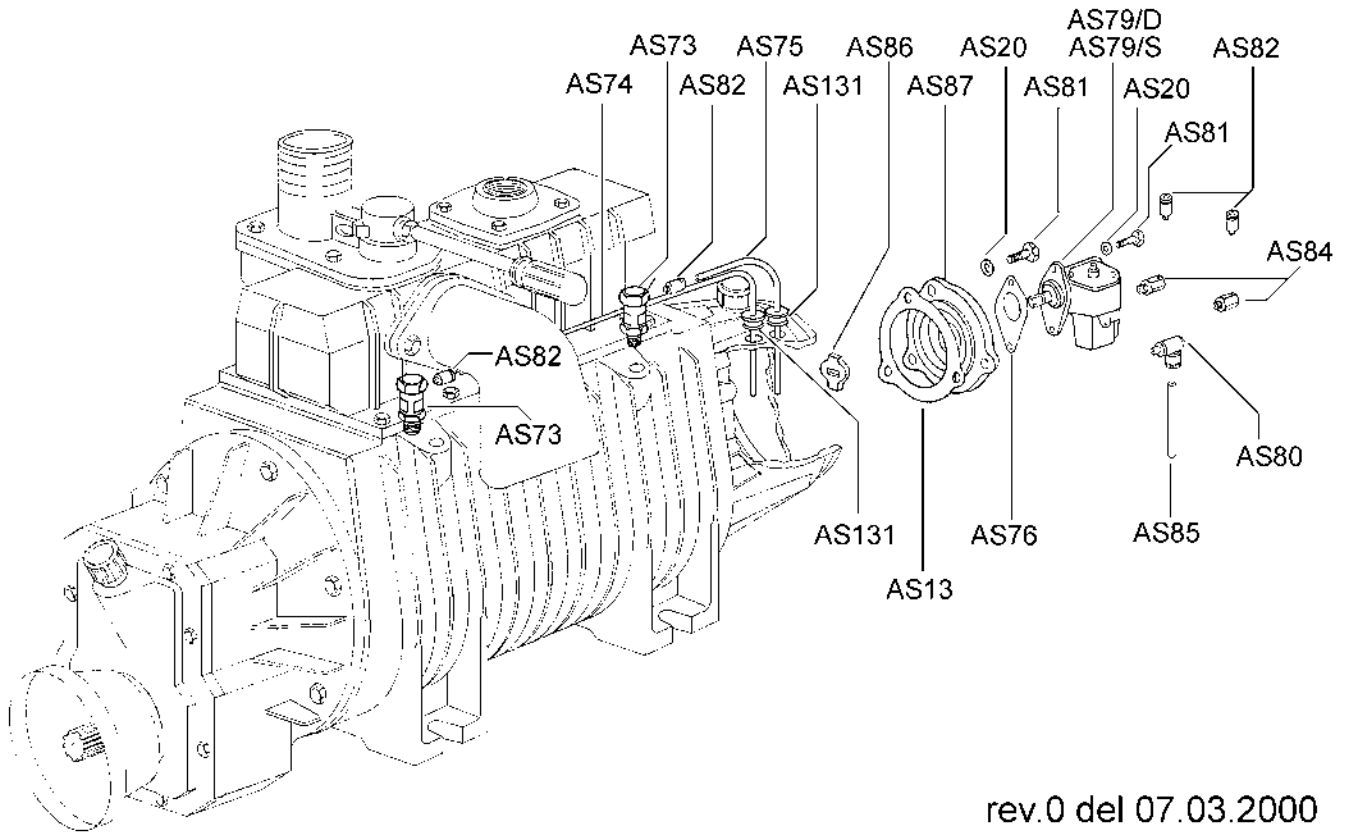

Item	Code	Description	Std	Quantity
AS 13	4030108018	Back cover gasket		1
AS 20	5050207002	Flat washer	6mm	3
AS 73	5040200005	Check glass		1
AS 74	5080105001	Lubrication hose	2x4x540	1
AS 75	5080105001	Lubrication hose	2x4x340	1
AS 76	4030108011	Oil pump gasket		1
AS 79/D	5080200011	Automatic lubrication pump	2 way - A.L. - DX	1
AS 79/S	5080200012	Automatic lubrication pump	2 way - A.L. - SX	1
AS 80	5040303007	Connector	1/8"x6x90 deg	1
AS 81	5050107005	Screw	M6x16TE	5
AS 82	5340303009	Straight connector	M5x4	4
AS 84	5040303005	Connector	8x1x20	2
AS 85	5080105002	Suction hose	4x6x80	1
AS 86	4010006002	Connector joint		1
AS 87	4010601024	A.L. pump support back cover		1
AS 131	4060310002	Tube-pass	4mm ID	2

Vacuum Pump Forced Lubrication (MEC5000 – 8000)

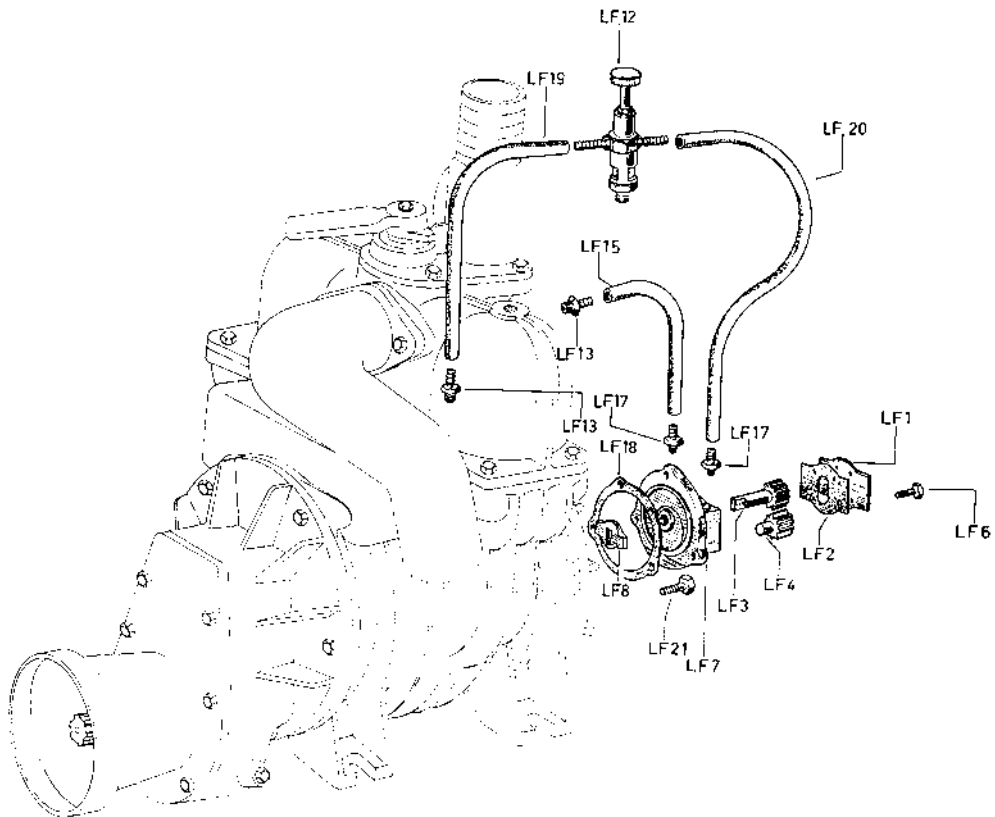

Vacuum Pump Forced Lubrication

Item	Code	Description	Std	Qty
LF 1	4010604001	Oil pump cover		1
LF 2	4030108030	Oil pump cover gasket F.L.		1
LF 3	4020507007	Driving gear		1
LF 4	4020507008	Driven gear		1
LF 6	5050107001	Screw	M5x12 TE	4
LF 7	4010101009	Oil pump body		1
LF 8	4010006002	Connector joint		1
LF 11	5040303003	Tube support	M10 x 1 x 90deg	1
LF 12	5040200003	Oil regulator tap	2-way x 180deg	1
LF 13	5040303004	Tube connector	M10x1	2
LF 14	5080110002	Return tube	5 x 10.5 x 170	1
LF 15	5080110002	Suction tube	5 x 10.5 x 170	1
LF 16	5080110002	Delivery tube	5 x 10.5 x 400	1
LF 17	5040303013	Tube support	M6x1	2
LF 18	4030108005	Back Cover Gasket		1
LF 19	5080110002	Return tube	5 x 10.5 x 210	1
LF 20	5080110002	Delivery tube	5 x 10.5 x 470	1
LF 21	5050107005	Screw	M6x16 TE	3
LF 22	5030210028	Pump ring seal F.L.	OR 86824	1

Vacuum Pump Automatic Lubrication (MEC6500 – 8000)

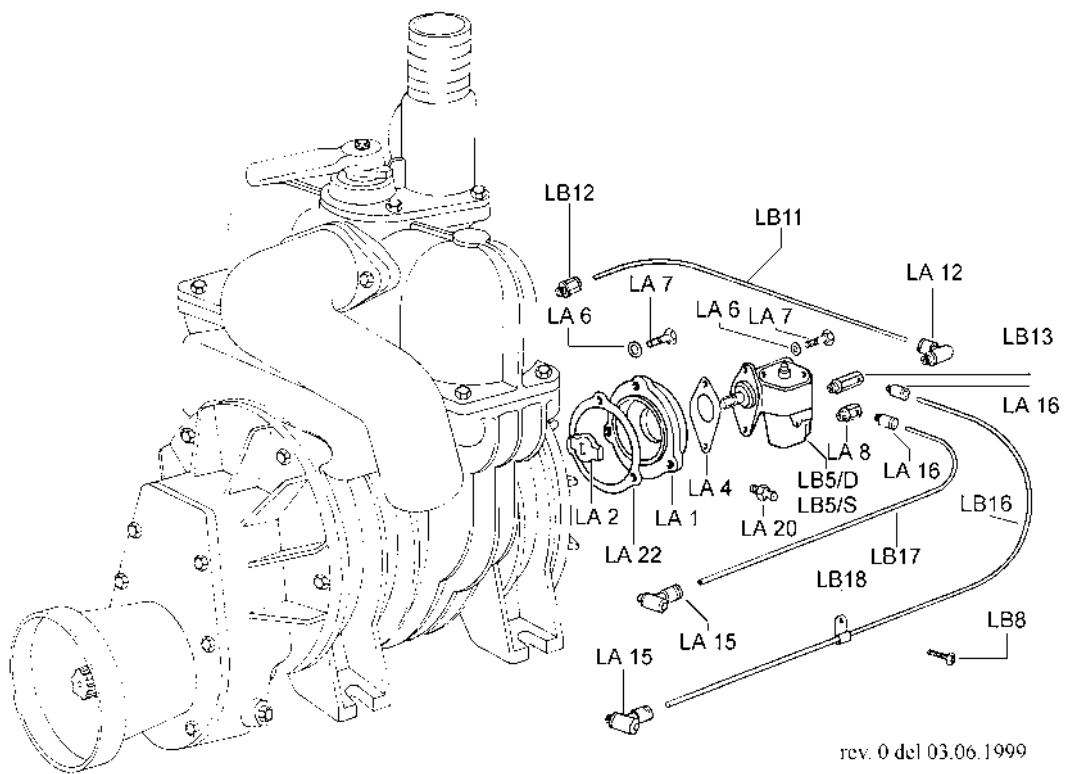

Vacuum Pump Automatic Lubrication

Item	Code	Description	Std	Qty
LA 1	4010601022	Oil pump support back cover		1
LA 2	4010006002	Connector joint		1
LA 4	4030108011	Oil pump gasket		1
LA 5/D	5080200009	Automatic lubrication pump	1 deliv. A.L right	1
LA 5/S	5080200010	Automatic lubrication pump	1 deliv. A.L left	1
LB 5/D	5080200011	Automatic lubrication pump	2 deliv. A.L right	1
LB 5/S	5080200012	Automatic lubrication pump	2 deliv. A.L left	1
LA 6	5050207002	Flat washer	6mm	5
LA 7	5050107005	Screw	M6 x 16 TE	5
LA 8	5040303005	Connector	8x1x20	1
LB 8	5050107001	Screw	M5x12 TE	1
LA 11	5080105002	Suction tube	4x6x240	1
LB 11	5080105002	Suction tube	4x6x260	1
LA 12	5040303007	Connector	1/8" x 6 x 90deg	2
LB 12	5040303011	Connector MEC 5000	1/8" x 6	1
LA 13	5080105001	Lubrication tube	2 x 4 x 470	1
LB 13	5040303006	Connector	8 x 1 x 30	1
LA 14	5040407001	Reduction	1/4" x 1/8" Gas	1
LA 15	5040303008	Connector	1/8" x 4 x 90deg	1
LA 16	5040303009	Straight connector	M5 x 4	1
LB 16	5050105001	Lubrication tube	2x4x690	1
LB 17	5080105001	Lubrication tube	2x4x290	1
LB 18	5080004002	Tube clamp	4mm	1
LA 20	5050812001	Lubricator	M10x1	1
LA 22	4030108005	Back cover gasket		1

Star 72 Lubrication Options

FORCE LUBRICATION

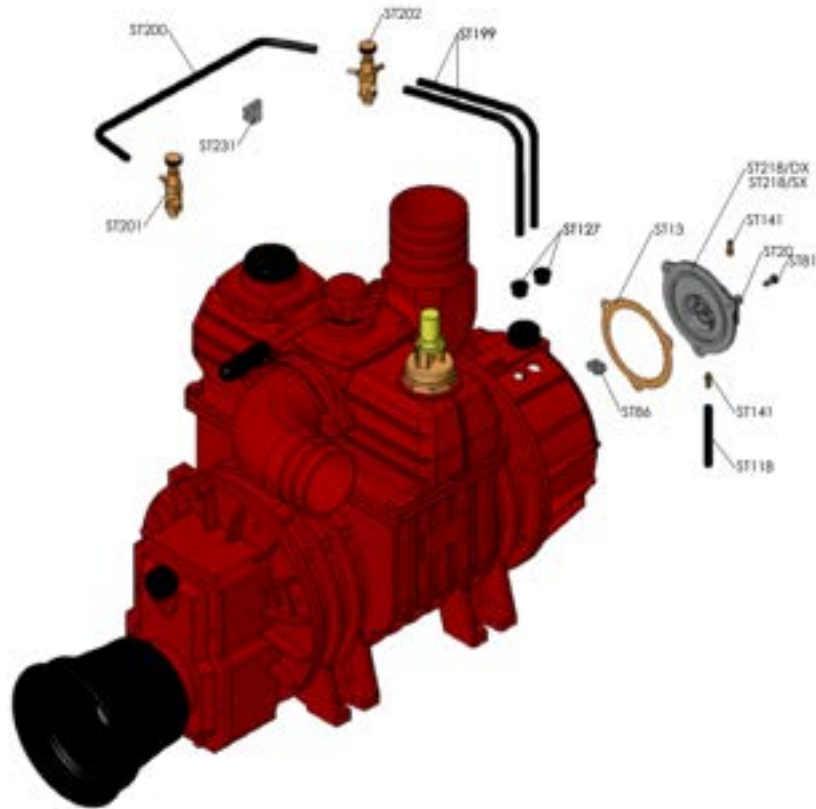

AUTO LUBRICATION

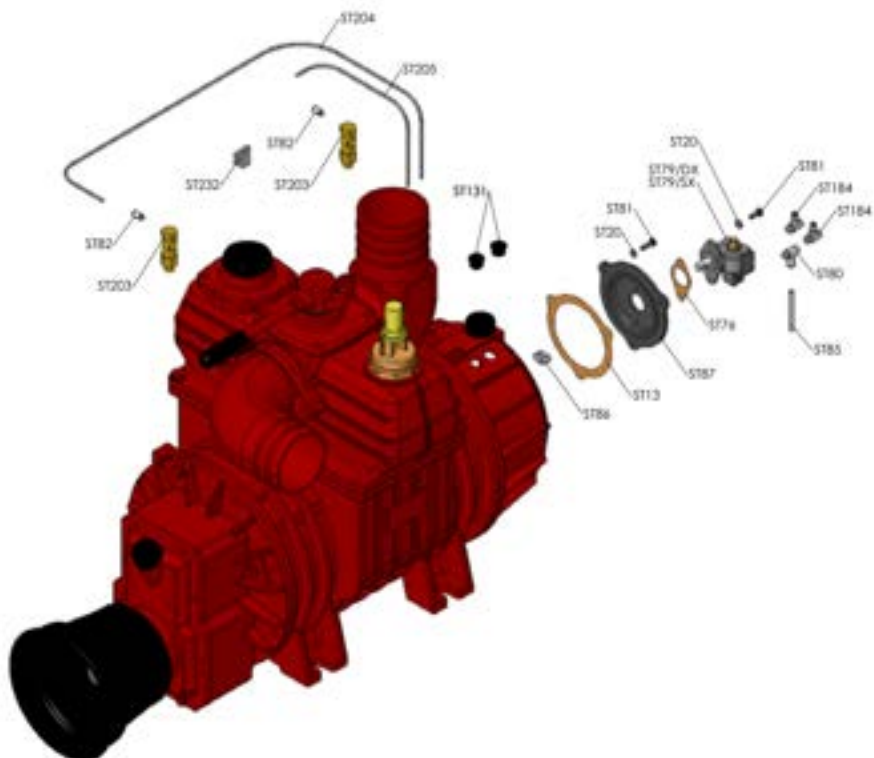

Star 72 Parts List

Articolo (Article)	Codice (Code)	(Description)	Qty	Um
ST1	4010101055	HOUSING - STAR60	1	n
STA1	4010101053	HOUSING - STAR72	1	n
STAR1	4010101054	HOUSING - STAR84	1	n
ST2	4010301010	GEARBOX - STAR	1	n
ST3	4011401002	BACK TANK - STAR	1	n
ST4	4030108017	BODY GASKET - STAR	3	n
ST6/10	5050707027	KEY - 10X8X30	1	n
ST7	4070113027	STANDARD BLADE - STAR60 350X70X7.5	6	n
STA7	4070113028	STANDARD BLADE - STAR72 400X70X7.5	6	n
STAR7	4070113117	STANDARD BLADE - STAR84 480X70X7.5	6	n
ST7/SP	4070113128	LONG LIFE BLADE - STAR60 350X70X7.5	6	n
STA7/SP	4070113129	LONG LIFE BLADE - STAR72 400X70X7.5	6	n
STAR7/SP	4070113130	LONG LIFE BLADE - STAR84 480X70X7.5	6	n
ST8	4011501026	SUCTION ELBOW - D 76 STAR	1	n
STA8	4011501027	SUCTION ELBOW - D 80 STAR	1	n
STAR8	4011501028	SUCTION ELBOW - D 100 STAR	1	n
ST9	5050307004	NUT - M 12	1	n
ST10	4010801005	REVERSE SELECTOR - STAR-WPT	1	n
ST11	5050107008	SCREW - M 6X16 TCEI	6	n
ST12	5012107011	BALL BEARING - 6308	1	n
ST13	4030108018	BACK COVER GASKET - STAR	1	n
ST14	5050202007	ALUMINIUM WASHER - D 16X20X1,5	2	n
ST15	4011912001	HANDLE PIN - STAR-WPT	1	n
ST17	5050207004	SMOOTH WASHER - D 10	4	n
ST18	5030300013	OIL SEAL - 55X68X8	4	n
ST20	5050207002	SMOOTH WASHER - D 6	3	n
ST21	5060605002	OIL PLUG - D 1/2" GAS	1	n
ST23	5050107018	SCREW - M 10X16 TE	2	n
ST24	5050202002	ALUMINIUM WASHER - D 10X16X1,5	2	n
ST25	5012107009	BALL BEARING - 6306	1	n
ST26/M	4020507005	GEAR WITH SHAFT - Z52-M2,5 STAR-WPT/M	1	n
ST26/MA	4020507009	GEAR WITH SHAFT - Z44-M2,5 STAR-WPT/MA	1	n
ST27	5030300014	OIL SEAL - 40X62X10	1	n
ST28	4030108019	GEARBOX COVER GASKET - STAR	1	n

Articolo (Article)	Codice (Code)	(Description)	Qty	Um
ST29	4010601118	GEARBOX COVER - STAR-WPT/M - CE	1	n
ST30	5060105004	OIL LEVEL PLUG - D 3/8" GAS	1	n
ST31	5060010001	HANDLE KNOB - WPT-STAR	1	n
ST32	5050300005	SELF-LOCKING NUT - M 30X2X19	1	n
ST33/M	4020607040	PINION - Z26-M2,5 STAR-WPT/M 10MM	1	n
ST33/MA	4020607041	PINION - Z34-M2,5 STAR-WPT/MA 10MM	1	n
ST38	4010501015	MANIFOLD - STAR UL	1	n
ST39	4030109030	MANIFOLD GASKET - STAR	1	n
ST40	5030300015	OIL SEAL - 35X50X7 TC	1	n
ST46	4012007004	SPRING - STAR-WPT	1	n
ST47	4010701010	REVERSING GEAR - STAR- WPT	1	n
ST48	5012107012	BALL BEARING - 6309	2	n
ST49	4010601045	VALVE COVER - STAR	1	n
ST50	4030109017	VALVE COVER GASKET - STAR	1	n
ST56	5060410007	RUBBER BALL - D 90	1	n
ST57	4010601040	OIL TANK COVER - STAR	1	n
ST58	5030210003	SEAL RING - OR 4700 STAR	1	n
ST59	4010401015	FRONT FLANGE - STAR/P-D-H	1	n
ST60	5030300016	OIL SEAL - 65X85X10	1	n
ST62	4030108020	FRONT COVER GASKET - STAR/D-P	1	n
ST63	5050812001	LUBRICATOR - M 10X1	1	n
ST65/12	5050707028	KEY - 12X8X50	1	n
ST71/3,5	4011001086	HYDRAULIC MOTOR SUPPORT - STAR/H GR. 3,5	1	n
ST71/4	4011001003	HYDRAULIC MOTOR SUPPORT - STAR/H GR. 4	1	n
ST72/3,5	4020107033	HYDR. MOTOR TRANSM. COUPL.STAR-WPT GR3,5	1	n
ST72/4	4020107018	HYDR. MOTOR TRANSM. COUPLING STAR-WPT	1	n
ST76	4030108011	OIL PUMP GASKET - L.A.	1	n
ST77	4010601056	MANIFOLD COVER - MEC 9_13500-STAR-WPT/UL	1	n
ST78	4030109025	MANIFOLD COVER GASK-MEC 9_13500-STAR-WPT	1	n
ST79/DX	5080200036	OIL PUMP - LA 2 WAYS AL DX IIS	1	n
ST79/SX	5080200038	OIL PUMP - LA 2 WAYS AL SX IIS	1	n
ST80	5040303007	CONNECTOR - D 1/8"X6X90° RILSAN	1	n
ST81	5050107107	GALVANIZED SCREW - M 6X10 TEF	4	n

Articolo (Article)	Codice (Code)	(Description)	Qty	Um
ST82	5040303009	STRAIGHT CONNECTOR - M 5X4 RILSAN	2	n
ST85	5080105002	SUCTION HOSE - D 4X6 RILSAN	0,07	m
ST86	4010006002	CONNECTOR JOINT - L.E.	1	n
ST87	4010601024	OIL PUMP SUPPORT BACK COVER - STAR L.A.	1	n
ST99	4030108021	GEARBOX COVER GASKET - STAR/K	1	n
ST101	5050107143	SCREW - M 8X30 TCEI	2	n
ST118	5080110002	RUBBER HOSE - D 5X11	0,3	m
ST127	4060310001	CLOSED TUBE-PASS	2	n
ST131	4060310002	TUBE-PASS - HOLE D 4	2	n
ST132	5060605003	OIL CHARGE PLUG WITH ROD - D 1/2" GAS	1	n
ST135	4010601042	FRONT COVER - STAR/P-D	1	n
ST136	5030300022	OIL SEAL - 45X65X10	1	n
ST137/12	5050707016	KEY - 12X8X80	1	n
ST140	5060605001	OIL PLUG - D 3/8" GAS	1	n
ST142	5030210008	SEAL RING - OR 189 STARUL	2	n
ST143	4010406017	FLANGE FOR ELBOW - STAR D80	2	n
STA143	4010406015	FLANGE FOR ELBOW - STAR D100	2	n
ST144	5050107054	SCREW - M 10X35 TE	6	n
ST145	4010901018	REVOLVING ELBOW - MEC 9_13500-STAR D 76	2	n
STA145	4010901019	REVOLVING ELBOW - MEC 9_13500-STAR D 80	2	n
STAR145	4010901020	REVOLVING ELBOW - MEC 9_13500-STAR D 100	2	n
ST149/84	4060505000	SHAFT GUARD - CE	1	n
ST149/84	4060505018	SHAFT GUARD - GARDA-LEDRA CE	1	n
ST155	5050906006	PLUG - D 16X1,5 DIN 908	2	n
ST161	5080110002	RUBBER HOSE - D 5X11	0,55	m
ST163	4010401042	BACK FLANGE - STAR	1	n
ST167	5050107028	SCREW - M 12X35 TE	4	n
ST168	5050207005	SMOOTH WASHER - D 12	4	n
ST169	4010401040	PUMP SUPPORT FLANGE - STAR/G	1	n
ST170/G	4020607044	GARDA PINION - Z45-M3 STAR/G 10MM	1	n
ST171/GA	4020607043	GARDA PINION - Z56-M3 STAR/GA 10MM	1	n
ST172	5050107026	SCREW - M 10X25 TCEI	6	n
ST173	4030108047	DECOMPRESS. SUPPORT GASKET - STAR/G	1	n
ST182	5100200012	DEPRESSION VALVE - D 1"1/2 GAS	1	n

Articolo (Article)	Codice (Code)	(Description)	Qty	Um
ST184	5040303008	CONNECTOR - D 1/8"X4X90° RILSAN	2	n
ST187	5060605006	BLACK PLUG - D 2" GAS	1	n
ST199	5080110002	RUBBER HOSE - D 5X11 MM	0,68	m
ST200	5080110002	RUBBER HOSE - D 5X11 MM	0,2	m
ST201	5040200002	DRAIN COCK - 1 WAY	1	n
ST202	5040200008	DRAIN COCK - 3 WAY STAR	1	n
ST203	5040200005	CHECK LIGHT STAR/WPT	2	n
ST204	5080105001	LUBRICATION HOSE - D 2X4 RILSAN	0,47	m
ST205	5080105001	LUBRICATION HOSE - D 2X4 RILSAN	0,32	m
ST207	5030210060	SEAL RING - OR171.12x2.62 .../G	1	n
ST208	4010220132	CONTINUOUS CASTING ROTOR - STAR60	1	n
STA208	4010220131	CONTINUOUS CASTING ROTOR - STAR72	1	n
STAR208	4010220136	CONTINUOUS CASTING ROTOR - STAR84	1	n
ST209/M	4011907075	FRONT PIN - STAR/M-K-G-MA-KA	1	n
ST209/P	4011907072	FRONT PIN - STAR/P	1	n
ST209/D	4011912010	FASTENED FRONT PIN - STAR/D - ISO 500	1	n
ST209/H	4011907073	FRONT PIN - STAR/H	1	n
ST210	4011907065	REAR PIN - STAR	1	n
ST211	5050107103	SCREW - M 10X50 TCEI 12.9 UNI5931	12	n
ST212	4011707049	BEARING LOCKING RING - STAR/G-GA	1	n
ST213	5050107011	SCREW - M 8X16 TE	3	n
ST214	5050207022	WASHER - 8X23X4 - DIN 6340	3	n
ST215/K	4010601119	GEARBOX COVER - STAR/K GR.2-3 CE	1	n
ST215/KA	4010601147	GEARBOX COVER - STAR/KA - GR.2-3 CE	1	n
ST216	4010301011	GEARBOX - STAR/K-KA	1	n
ST218/DX	6080200003	PUMP - LF STAR CW	1	n
ST218/SX	6080200148	PUMP - LF STAR CCW	1	n
ST219/2	6080200128	HYDRAULIC PUMP SUPPORT - STAR GR. 2 IIS	1	n
ST219/3	6080200129	HYDRAULIC PUMP SUPPORT - STAR GR. 3 IIS	1	n
ST221	5050107050	SCREW M 10X90 TCEI	4	n
ST222	5040303015	STRAIGHT CONNECTOR - D 1/8"X6 RILSAN	1	n
ST223	5080105002	SUCTION HOSE - D 4X6 RILSAN	0,43	m
ST224	5050107108	SCREW - M 8X25 TEF - FL/ZIGR 8.8	12	n
ST225	5050107109	SCREW - M 10X25 TEF - FL/ZIGR 8.8	29	n

Articolo (Article)	Codice (Code)	(Description)	Qty	Um
ST226	4011707024	FLANGE RING NUT - STAR-WPT/GA	1	n
ST227	4030110023	HYDR. PUMP SUPPORT GASKET - G.2/G.3	1	n
ST228	5051007001	DOWEL - M 6X10	3	n
ST229/3,5	4030108046	HYDRAULIC MOTOR SUPPORT GASKET - GR3,5	1	n
ST229/4	4030108028	HYDRAULIC MOTOR SUPPORT GASKET - GR4	1	n
ST231	5080004003	HOSE CLAMP - D 10 LF	1	n
ST232	5080004002	HOSE CLAMP - D 4 L.A.	1	n
ST246/3,5	6080200059	HYDRAULIC MOTOR KM 30.73 SO GR.3,5	1	n
ST246/4	6080200061	HYDRAULIC MOTOR KM 40.87 SO GR.4	1	n
ST247	5050107061	SCREW - M 12X45 TCEI	4	n
ST248	4011406012	OIL TANK THERMOFORMED	1	n
ST249	4011707112	SPACER FOR PLASTIC TANK	2	n
ST250	4010007062	PLASTIC OIL TANK SUPPORT FOR STAR-KTS	1	n
ST251	5080005001	OIL FILTER - WPT LA	1	n
ST252	5050202004	ALUMINIUM WASHER - D 1/2" GAS	1	n
ST253	4040407001	FILTER REDUCTION - WPT LA	1	n
ST254	5040200001	OIL TANK DRAIN COCK - D 1/4" GAS	1	n
ST255	5040407001	REDUCTION - D 1/4"X1/8" GAS	1	n
ST256	5050107025	SCREW - M 10X100 TE	2	n
ST257	4011707113	INSERT BRASS PLASTIC OIL TANK	2	n
ST259	5040303029	CONNECTOR - D 1/8" GAS LF	1	n
ST260	5060605014	CHARGE OIL PLUG - D 1" GAS	1	n
ST261	5050207024	GALVANIZED FLAT WASHER - D 10	2	n
ST262	4020807027	GARDA PINION - Z56-M3 STAR/GA 10MM	1	n
ST263	4020907069	SPLINED SLEEVE - GARDA T MEC/STAR	1	n
ST264	5050107016	SCREW - M 8X25 TCEI	8	n
ST265	5050207034	SECURITY WASHER - D10	1	n
ST266	5050107099	GALVANIZED SCREW - M 10X45 TE	1	n
ST267	4011707055	SPLINED SMOOTH WASHER - GARDA T	1	n
ST268	4020107034	SLIDING SLEEVE - GARDA EVO	1	n
ST269	5050507029	CIRCLIP - D 55 E - DIN 471	1	n
ST270	4011707115	SPACER PIN GA T	1	n
ST271	5050812002	LUBRICATOR - M 10X1X45°	1	n

Articolo (Article)	Codice (Code)	(Description)	Qty	Um
ST230	6010201011	REBUILD KIT - STAR 60 STANDARD	1	n
STA230	6010201012	REBUILD KIT - STAR 72 STANDARD	1	n
STAR230	6010201013	REBUILD KIT - STAR 84 STANDARD	1	n
ST230/SP	6010201024	REBUILD KIT - STAR 60 LONG LIFE	1	n
STA230/SP	6010201025	REBUILD KIT - STAR 72 LONG LIFE	1	n
STAR230/SP	6010201026	REBUILD KIT - STAR 84 LONG LIFE	1	n
LUBR_OIL	5070200100	BATTIONI PAGANI VACUUM PUMP OIL (5LT)	1	n

Garda Gearbox 6500 Mechanical Seal Parts List

Articolo (Article)	Codice (Code)	(Description)	Q.ty	Um
G1/MEC	4010301004	GEARBOX - GARDA / MEC	1	pcs
G1/MEC-TS	4010301024	GEARBOX - GARDA/MEC TS	1	pcs
AG1/WPT	4010301005	GEARBOX - GARDA / WPT-STAR	1	pcs
G5/540	4020807001	CENTRAL WHEEL - Z97-M3 GARDA	1	pcs
G6	4010601020	FRONT AND REAR COVER - GARDA	1	pcs
G7	4030108008	FRONT AND BACK COVER GASKET - GARDA	2	pcs
G8	4010007001	SHOE FOR GEAR - GARDA - LEDRA	2	pcs
G9	5050507002	CIRCLIP - D 12 E	1	pcs
G10	5050507003	CIRCLIP - D 25 E	1	pcs
G12	5012107010	BALL BEARING - 6307	3	pcs
G13	4010601021	GEARBOX COVER - GARDA	1	pcs
G14	5050107028	SCREW - M 12X35 TE	4	pcs
G15	5050207009	BLANK WASHER - D 8X32	1	pcs
G16	4010006001	GEARSHIFT FORK - GARDA	1	pcs
G17	4011907001	GEAR PIN - GARDA	1	pcs
G19	5050107009	SCREW - M 8X20 TE	7	pcs
G20	5050207004	SMOOTH WASHER - D 10	20	pcs
G22	4030108009	FRONT COVER GASKET - GARDA	1	pcs
G23	5050107018	SCREW - M 10X16 TE	1	pcs
G24	5050202002	ALUMINIUM WASHER - D 10X16X1,5	1	pcs

Articolo (Article)	Codice (Code)	(Description)	Q.ty	Um
G25	5030300005	OIL SEAL - 35X62X10	1	pcs
G26	4020907001	SPLINED CENTRAL SHAFT - GARDA	2	pcs
G27	4010801003	GEAR LEVER - GARDA	1	pcs
G28	5060105004	OIL LEVEL PLUG - D 3/8" GAS	1	pcs
G29	4030109007	GEARBOX COVER GASKET - GARDA	1	pcs
G30	5050207010	BLANK WASHER - D 30X56	1	pcs
G31	4012007003	SPRING - GARDA	1	pcs
G32	5030300008	OIL SEAL - 19X27X6	1	pcs
G33	5010007002	STEEL BALL - D 8.73	1	pcs
G34/540	4020907002	CENTRIFUGAL SHAFT - GARDA 6500 CG	1	pcs
G35	5012107014	BALL BEARING - 4210 A	1	pcs
G36	5050707007	KEY - 8X7X50	1	pcs
G37	5050300003	SELF-LOCKING NUT - M 30X2X25	1	pcs
G38	4011001001	SCROLL SUPPORT - GARDA 6500 CG	1	pcs
G39	5050107027	SCREW - M 12X30 TE	16	pcs
G40	5050207005	SMOOTH WASHER - D 12	24	pcs
G41	4030108010	SCROLL SUPPORT GASKET - GARDA	1	pcs
G42	5030210001	SEAL RING - D 298X3.53 GARDA 6500	2	pcs
G43	5050307004	NUT - M 12	2	pcs
G44	4050412001	STUD BOLT - M 12X107	2	pcs

Articolo (Article)	Codice (Code)	(Description)	Q.ty	Um
G45	5030300009	OIL SEAL - 50X70X10	1	pcs
G46	5030210015	RUBBER RING - HL 187 GARDA 6500	1	pcs
G47	4030111001	PRESHAPED RING - D 50X70X10 GARDA 6500	6	pcs
G48	4011301001	CORDHOLDER - GARDA 6500	1	pcs
G49	4011101001	SCROLL - GARDA 6500	1	pcs
G49/140	4011101004	SCROLL - GARDA 6500 - D 140	1	pcs
G50	5050906001	PLUG - D 1/4" GAS	1	pcs
G51	5050202003	ALUMINIUM WASHER - D 1/4" GAS	1	pcs
G52	4011219001	IMPELLER - GARDA 6500	1	pcs
G53	4010401009	SCROLL EXTERNAL FLANGE - 6500	1	pcs
G56	5051007005	DOWEL - M 10X25 P.P.	1	pcs
G57	5050307003	NUT - M 10	3	pcs
G58	4010601066	BACK COVER - GARDA	1	pcs
G59	4010401010	SCROLL EXTERNAL FLANGE WITH HOSE- 6500	1	pcs
G60/WPT1000	4010301006	GEARBOX - GARDA/WPT 1000RPM	1	pcs
G60/WPT-TS	4010301026	GEARBOX - GARDA/WPT TS 1000	1	pcs
G61/1000	4020807002	CENTRAL WHEEL - Z86-M3 GARDA 1000 RPM	1	pcs
G62/1000	4020907003	CENTRIFUGAL SHAFT - GARDA 6500 CG	1	pcs
G68	4011703001	BUSHING - D 30X40X60 GARDA 3500	1	pcs
G71	4011101002	SCROLL - GARDA 3500	1	pcs
Articolo (Article)	Codice (Code)	(Description)	Q.ty	Um
G72	5030210006	SEAL RING - OR 4950 ELBA 3500	1	pcs
G73	4011219002	IMPELLER - GARDA 3500	1	pcs
G74	4011001007	SCROLL SUPPORT - GARDA 3500 CG	1	pcs
G75	5030210017	RUBBER RING - HL 150 GARDA 3500	1	pcs
G77	5050107045	SCREW - M 12X30 TSEI	4	pcs
G78	4030111002	PRESHAPED RING - D 40X56X8 GARDA 3500	4	pcs
G79	4011301002	CORDHOLDER - GARDA 3500	1	pcs
G81	4050412002	STUD BOLT - M 10X60	2	pcs
G82	4030108025	SCROLL SUPPORT GASKET - GARDA 3500	1	pcs
G84	4010401028	CONNECTION FLANGE - GARDA 3500	1	pcs
G85	4020907004	CENTRIFUGAL SHAFT - GARDA 3500 CG	1	pcs
G86	5050707006	KEY - 8X7X35	1	pcs
G88	4010401029	CLOSING FLANGE - GARDA CUTT. DEV.	1	pcs
G89	4010006005	BLADE FOR CUTTING DEVICE	1	pcs
G90	4010006006	COUNTE-BLADE FOR CUTTING DEVICE	2	pcs
G91	4010401027	BLADE-HOLDER FLANGE - GARDA CUTT. DEV.	1	pcs
G92	4010007002	EXTENSION FOR CUTTING DEVICE	1	pcs
G92/140	4010007009	CUTTING DEVICE EXTENSION - SCROLL D 150	1	pcs
G93	4011707011	CUTTING DEVICE SPACER - GARDA	1	pcs
G96	5050107021	SCREW - M 10X30 TE	6	pcs

Articolo (Article)	Codice (Code)	(Description)	Q.ty	Um
G98	5030000003	MECHANICAL SEAL - GARDA 6500	1	pcs
G99/540	4020907010	CENTRIFUGAL SHAFT - GARDA 6500 TM	1	pcs
G100	4011001033	SCROLL SUPPORT - GARDA 6500 TM	1	pcs
G101/1000	4020907013	CENTRIFUGAL SHAFT - GARDA 6500 TM 1000	1	pcs
G102	5060010003	HANDLE KNOB - GARDA/6500	1	pcs
G103	4010601122	GEARBOX FRONT COVER - GARDA CE	1	pcs
G107	4020907055	CENTRIFUGAL SHAFT - GARDA 3500 TM	1	pcs
G108	5030000006	MECHANICAL SEAL - GARDA 3500	1	pcs
G109	4011001037	SCROLL SUPPORT - GARDA 3500 TM	1	pcs
G126	5050107093	SCREW - M 8X45 TE	8	pcs
G127	5050300002	SELF-LOCKING NUT - M 27X2X16	1	pcs
G128	5050707004	KEY - 8X7X25	1	pcs
G130	4060505018	SHAFT GUARD - GARDA-LEDRA CE	2	pcs
G132	5050107084	SCREW - M 6X16 TEF	4	pcs
G156	5050107109	SCREW - M 10X25 TEF - FL/ZIGR 8.8	12	pcs
G160	4011707061	SPACER - D35,5X45X1	1	pcs

ADR Axle Hub

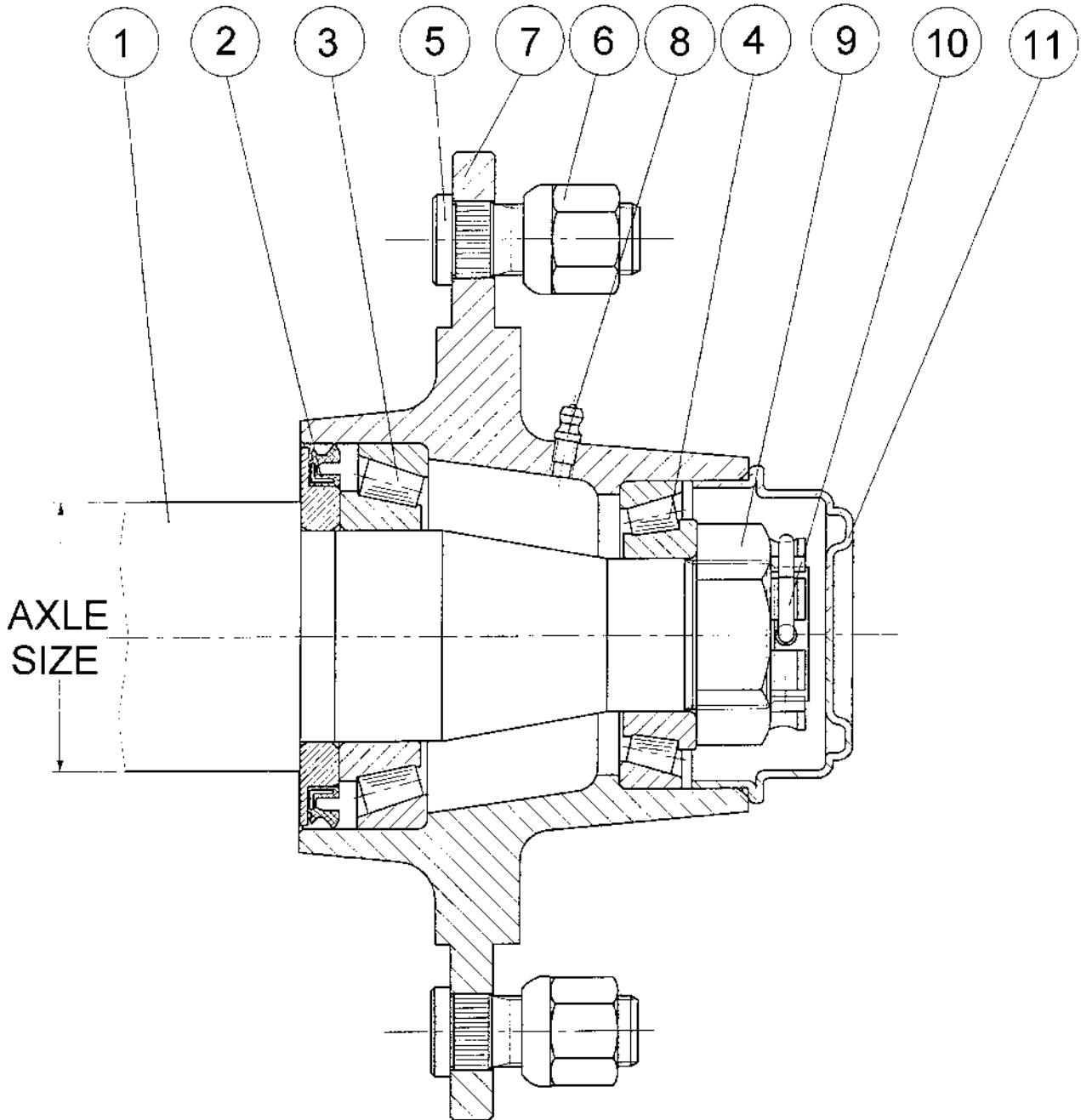

ADR Axle Hub

Item	Part Number	Description	Quantity			
			60mm	70mm	80mm	90mm
1	HUB2000KG	Complete Stub Axle, ADR 6 stud 60sq	1			
1	HUB3000KG	Complete Stub Axle, ADR 6 stud 70sq		1		
1	HUB4250KG	Complete Stub Axle, ADR 8 stud 80sq			1	
1	HUB5000KG	Complete Stub Axle, ADR 8 stud 90sq				1
2	110-0193	Seal 57x100x10 O/A (80x100x8 nom.)	1			
2	110-0194	Seal 67x120x12 O/A (100x120x10 nom.)		1		
2	110-0195	Seal 78x130x10 O/A (108x130x8 nom.)			1	
2	110-0196	Seal 82x140x10 O/A (119x140x8 nom.)				1
3	BRG30211J2	Taper Roller Bearing, 30211 J2	1			
3	BRG30213J2	Taper Roller Bearing, 30213 J2		1		
3	BRG32215J2	Taper Roller Bearing, 32215 J2			1	
3	BRG32216J2	Taper Roller Bearing, 32216 J2				1
4	BRG30208J2	Taper Roller Bearing, 30208 J2	1			
4	BRG32210J2	Taper Roller Bearing, 32210 J2		1		
4	BRG32212J2	Taper Roller Bearing, 32212 J2			1	
4	BRG32113J2	Taper Roller Bearing, 32213 J2				1
5	110-0945	Wheel Stud, M18x50	6	6	8	
5	110-0950	Wheel Stud, M20x60x1.5				8
6	110-0917	Wheel Nut, M18	6	6	8	
6	110-0919	Wheel Nut, M20x1.5				8
7	-	Hub Only, ADR 2350 kg 6 stud	1			
7	-	Hub Only, ADR 3400 kg 6 stud		1		
7	-	Hub Only, ADR 4250 kg 8 stud			1	
7	-	Hub Only, ADR 5000 kg 8 stud				1
8	GRN8-45	Grease Nipple, M8x1.0 45 deg	1	1	1	1
9	110-1047	Slotted Nut, M39x1.5	1			
9	110-1047	Slotted Nut, M39x1.5		1		
9	110-1060	Slotted Washer Nut, M48x1.5			1	
9	110-1060	Slotted Washer Nut, M48x1.5				1
10	-	Retaining Clip (or Split Pin SP5x70)	1			
10	-	Retaining Clip (or Split Pin SP5x70)		1		
10	-	Retaining Clip (or Split Pin SP5x80)			1	
10	-	Retaining Clip (or Split Pin SP5x90)				1
11	110-0799	Grease Cap ADR Pressed Steel - 80mm	1			
11	110-0881	Grease Cap ADR Pressed Steel - 90mm		1		
11	110-0883	Grease Cap ADR Pressed Steel - 110mm			1	
11	110-0884	Grease Cap ADR Pressed Steel - 120mm				1

Single Axle Assembly – M7500

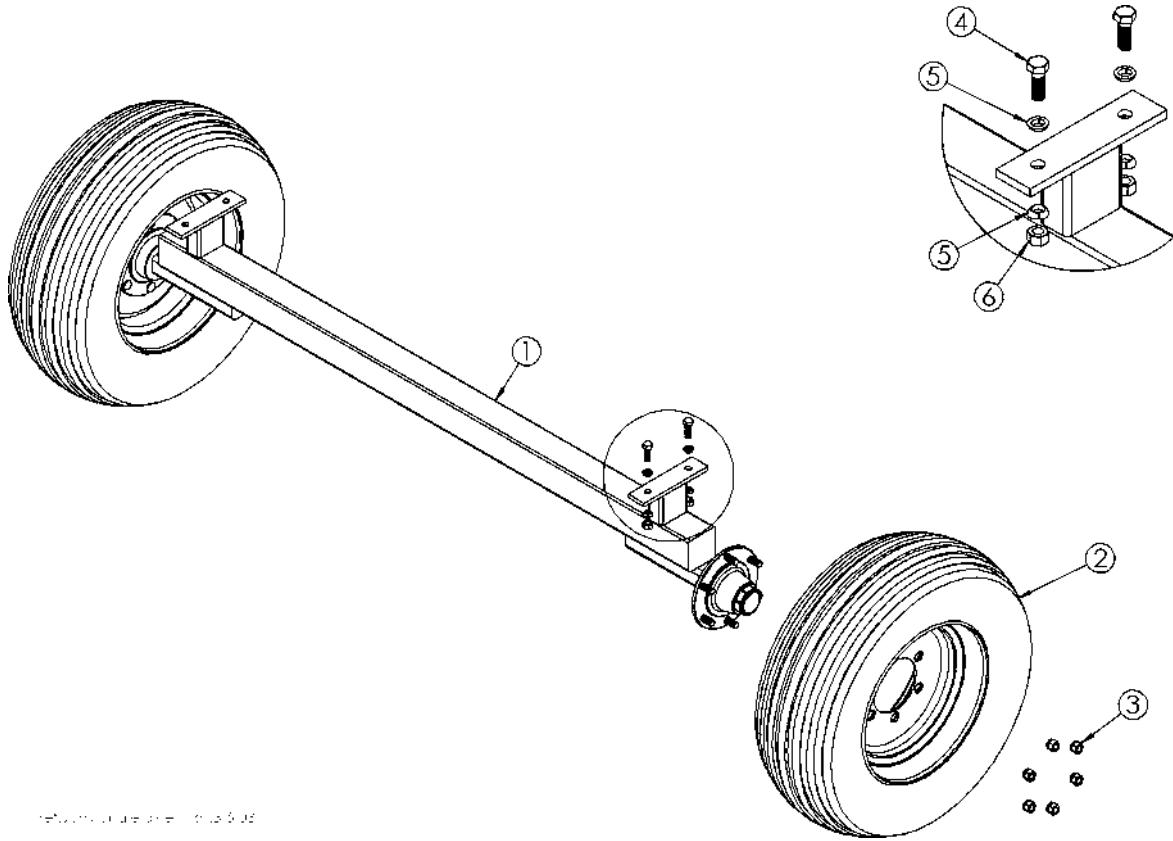

595-0003 Slurry Operating Manual

Item	Part Number	Description	Quantity
-	-	Axle Beam, 80sq Hubs	1
2	-	Wheel Assembly, 15Rx22.5	2
2	-	Wheel Assembly, 500/45-22.5	2
3	110-0917	Wheel Nut, M18x1.5	12
4	B16x45	Bolt, M16x45	4
5	S51239	Washer, Conical M16	8

6	N16	Nut, M16	4
---	-----	----------	---

Tandem Axle Assembly - M5000 & M7500

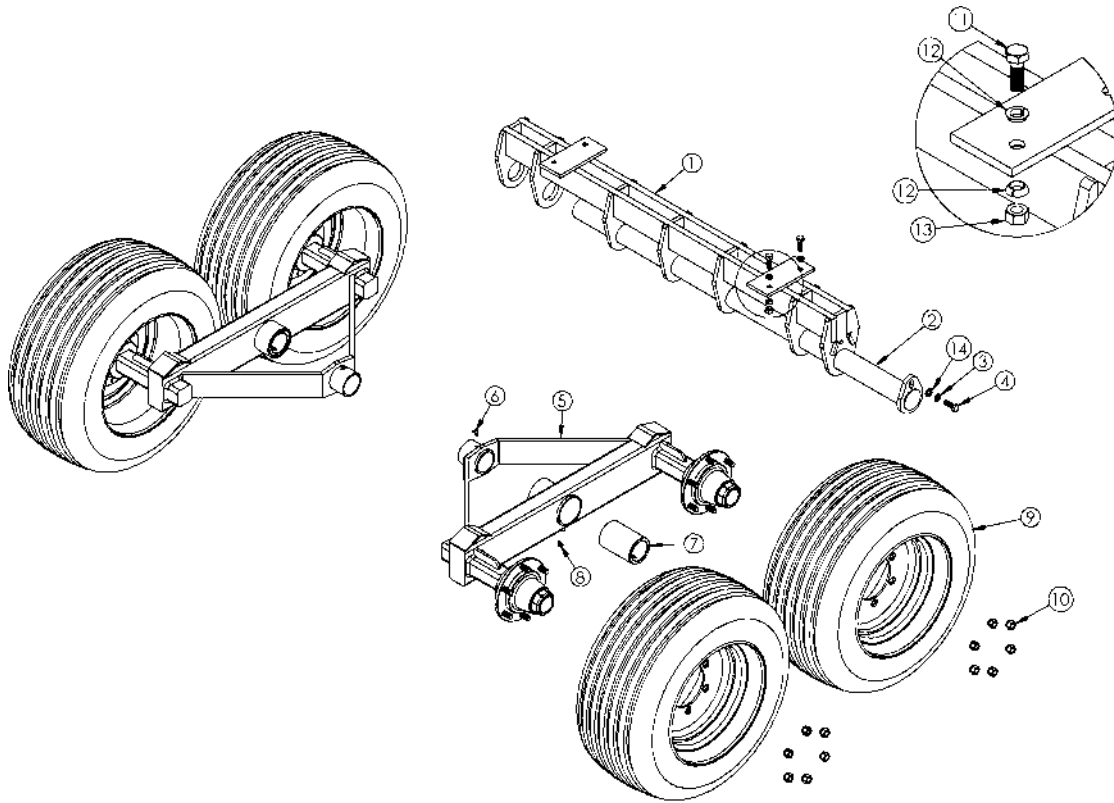

n-52301 Slurry Brakes - 3/24/03

Item	Part Number	Description	Quantity Used	
			M5000	M7500
1	-	Axle Beam	1	-
1	-	Axle Beam	-	1
2	-	Axle Pin	-	1
3	WASG16	Washer, Spring M16	-	1
4	B16x30	Bolt, M16x30	-	1
5	-	Hub Mount, 60sq Hubs	2	-
5	110-0264	Hub Mount, 70sq Hubs	-	2
6	GRN1/8-90	Grease Nipple, 1/8" BSP 90deg	-	4
7	110-0114	Bush	-	2
8	GRN1/8-90	Grease Nipple, 1/8" BSP 90deg	2	2
9	-	Wheel Assembly, 11.5/80x15.3	4	-
9	-	Wheel Assembly, 400/60x15.5	opt.	4
10	110-0917	Wheel Nut, M18x1.5	12	24
11	B16x45	Bolt, M16x45	4	4
12	S51239	Washer, Conical M16	8	8
13	N16	Nut, M16	4	4

14	WA16	Washer, Flat M16	1	1
----	------	------------------	---	---

Tandem Axle Assembly - M10000

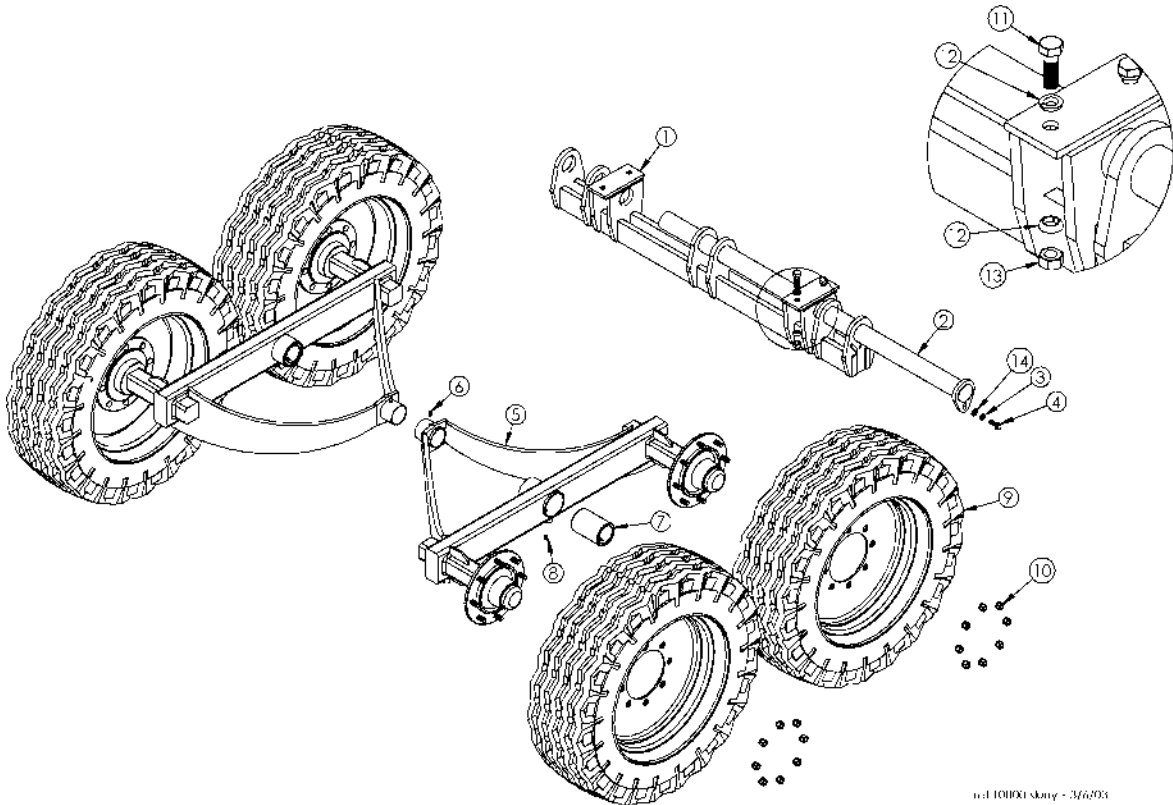

n.d.10000 Slurry - 3/6/203

Item	Giltrap Part #	Description	Quantity
1	110-0563	Axle Beam	1
2	110-0514	Axle Pin	1
3	WASG16	Washer, Spring M16	1
4	B16x30	Bolt, M16x30	1
5	110-0285	Hub Mount, 80sq Hubs	2
6	GRN1/8-90	Grease Nipple, 1/8" BSP 90deg	2
7	110-0114	Plastic Bush	2
8	GRN1/8-90	Grease Nipple, 1/8" BSP 90deg	2
9	-	Wheel Assembly, 15Rx22.5	4
10	110-0917	Wheel Nut, M18x1.5	24
11	B20x45	Bolt, M20x45	4
12	S51245	Washer, Conical M20	8
13	N120	Nut, M20	4
14	WA16	Washer, Flat M16	1

Steering Axle Parts Break Down

Steering Axle Self-Steer

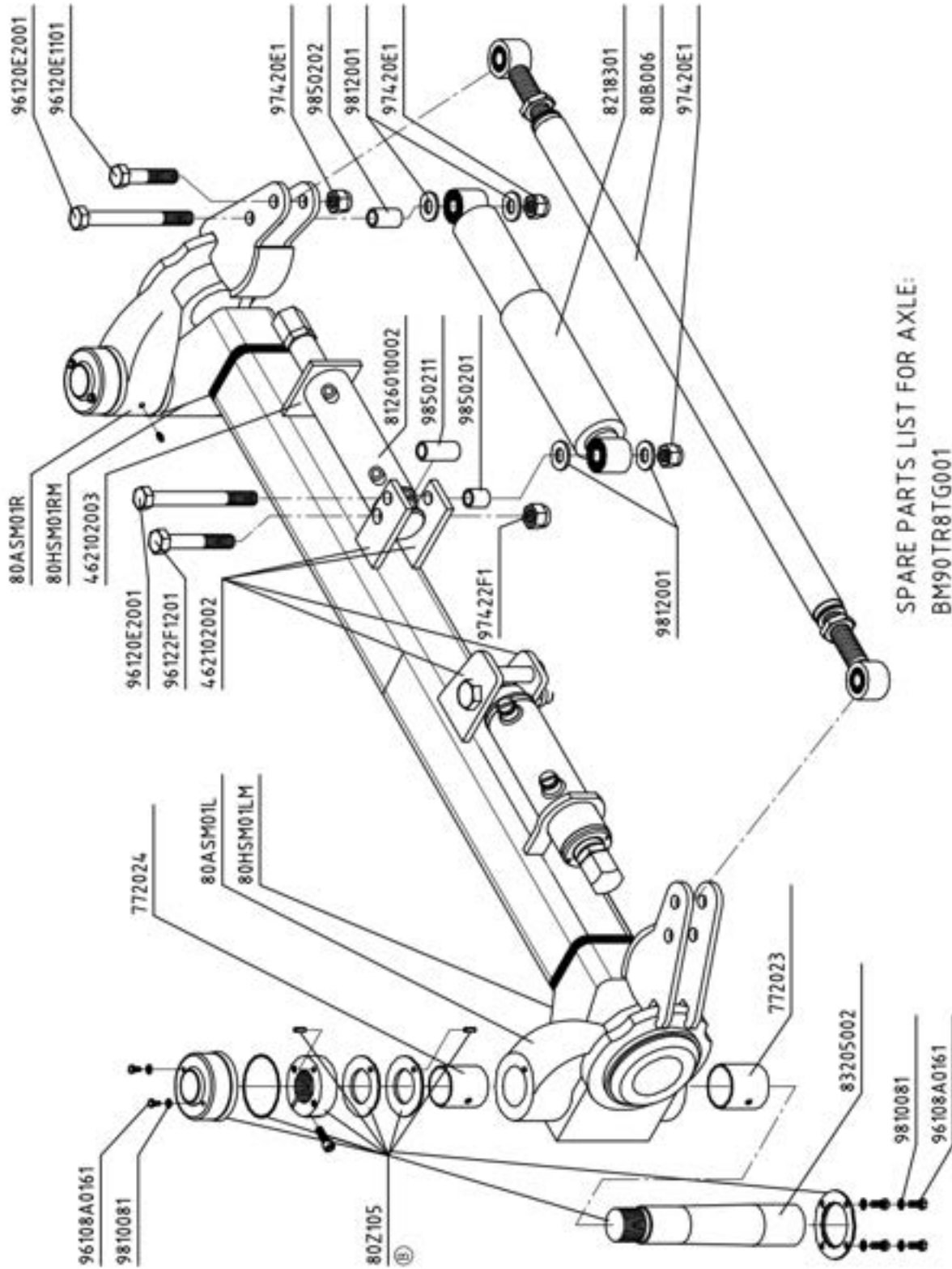

ARD Hub Assembly

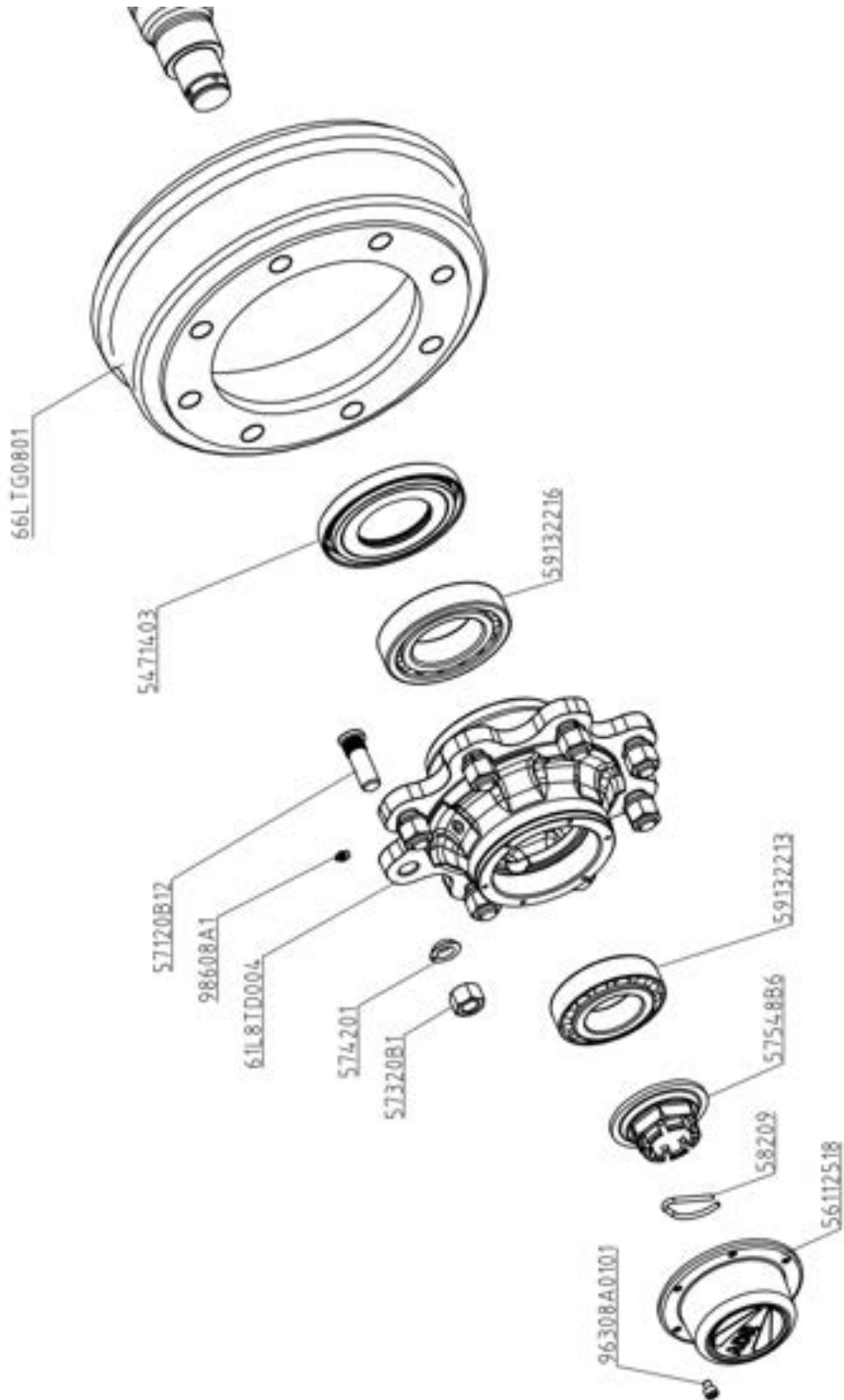

Steering Axle parts list

BM90TR8TG001		
Component	Description	Link Quantity
96120E1101	SCREW EH M20X2,50 L110 CA08,8	2
96108A0161	SCREW EH M08X1,25 L016 CR08,8	10
9810081	WASHER M08 D008,4 D016 TK1,6	10
80Z105	ASSEMBLY FOR RING-NUT SM	2
98608A2	GREASE NIPPLE 45° M08X1.25	4
80B006	COUPLING BAR L1890-2189	1
8218301	SHOCK ABSORBER D080 S241	1
9.74E+05	SELF LOCKING NUT M20X2.50 CA8	2
9812001	WASHER D020.5 D050 TK 4.0	4
9850201	SPACER D020.5/038 L032	1
9850202	SPACER D020.5/038 L045	1
9850211	SPACER D021/26.9 L060	1
96120E2001	SCREW EH M20X2,50 L200 CA08,8	2
8126010002	HYDR CYLINDER D060/040 S100	2
97422F1	SELF LOCKING NUT M22X2,50 CA8	2
96122F1201	SCREW EH M22X2,50 L120 CA08,8	2
80ASM01R	OUTER ARM RG COMPLETE 10 SM	1
80ASM01L	OUTER ARM LF COMPLETE 10 SM	1
741TG9015	BRAKE SUPPORT 408E S090	2
7503552006	CAM SHAFT D35 B0225 FLAT	2
58513	SEEGER D038 DIN471 FOR SHAFT	2
58511	SEEGER D032 DIN471 FOR SHAFT	2
97124B1	NUT M24X1.50 DIN 934	2
53A08	RUBBER CAP FOR CAM SHAFT Ø35	2
9800241	TWIN WASHER M24	2
74402752	SUPPORT STN B4SM 408E LEFT	1
74402652	SUPPORT STN B4SM 408E RIGHT	1
468002	ASSEMBLY SUPPORT PLATES	2
80HSM01LM	INNER ARM LF MACHINED SM 10	1
80HSM01RM	INNER ARM RG MACHINED SM 10	1
59132213	32213 065 120 32.75	2
59132216	32216 080 140 35.25	2
57120B12	STUD M20X1,50 L083	16
61L8TD004	HUB H08 20 120-140 220-275	2
98608A1	GREASENIPPLE STRAIGHT M08X1.25	2
5471403	GREASE SEAL INDUSTRIAL 082/140	2
66LTG0801	DRUM 400X080 H08 20 275-220	2
731TG01	BRAKE ASSEMBLY 400X080 408E	2
56112518	CAP 125 BOLT ON ADR	2
57548B6	CROWN NUT M48X1.50 WR65 H44	2

BM90TR8TG001		
Component	Description	Link Quantity
58209	SPRING PIN FOR NUT M48	2
96308A0101	SCREW SH M08X1,25 L010	12
7611503	LEVER 35 BNA FIXED	2
462121002	PLATE TK12 S235JR EN10025	2
813104	ASSEMBLY CYLIND D030/025 S110	2
574201	LIMES WASHER FOR M20	16
57320B1	STUD NUT M20X1.50 WR30	16

C5S3UD1TG001		
Component	Description	Link Quantity
72UFB10013	BODY STUBAXLE R110 LAM FF0230	1
80AST38R	OUTER ARM RIGHT 0 STA STB	1
80AST38L	OUTER ARM LEFT 0 STA STB	1
7DTGB1UN001	BRAKE ASSEMBLY 400x080 408E	2
741TGB122	BRAKE SUPPORT 408E R110	2
7503552006	CAM SHAFT D35 B0225 FLAT	2
58513	SEEGER D038 DIN471 FOR SHAFT	2
58511	SEEGER D032 DIN471 FOR SHAFT	2
97124B1	NUT M24X1.50 DIN 934	2
9800241	TWIN WASHER M24	2
53A08	RUBBER CAP FOR CAM SHAFT Ø35	2
74402680	SUPPORT STA 090A 408E RIGHT	1
74402780	SUPPORT STA 090A 408E LEFT	1
46A164	CYLIND SUPPORT S120 S130 S150	1
80HSA05RM	INNER ARM RG STA-STB 0 T130X14	1
80HSA05LM	INNER ARM LF STA-STB 0 T130X14	1
96110B0141	SCREW EH M10X1,50 L014 CA08,8	10
9830101	GROWER WASHER M010 DIN127	10
80Z104	ASSEMBLY FOR RING-NUT STN	2
98608A2	GREASE NIPPLE 45° M08X1.25	4
986081C	CAP FOR GREASE NIPPLE	4
96820B0531	BOLT SPECIAL M20X1,50 L053,5	2
8128520503	CYLINDER HYDR D085/045 S205 DA	1
98A28B1	AXIALBALLJOINT M24X1,5 M28X1,5	2
98930F13	BALL JOINT RG M30X3.00 L0278	2
80BG24	MAIN BODY L0370	2
46A182	SUPPORT D045 SHOCK ABSORBER	1
96120E1101	SCREW EH M20X2,50 L110 CA08,8	1
ZS005	DUALMODE HYDRAULIC PLANTS	1
8215501	SHOCK ABSORBER D055 S242	1
96120E1001	SCREW EH M20X2,50 L100 CA08,8	2
9850202	SPACER D020.5/038 L045	1

C5S3UD1TG001		
Component	Description	Link Quantity
46A186	PLATE SHOCK ABSORBER SUPPORT	2
96114D0501	SCREW EH M14X2,00 L050 CS08.8	4
9800141	TWIN WASHER M14	4
59133114	33114 070 120 37	2
59133018	33018 090 140 39	2
57122B15	STUD M22X1.50 L089	20
61L1UA004	HUB H10 22 120-140 280-335	2
98608A1	GREASENIPPLE STRAIGHT M08X1.25	2
66LTG1004	DRUM 400X080 H10 22 335-280	2
5471404	GREASE SEAL INDUSTRIAL 092/140	2
731TG01	BRAKE ASSEMBLY 400X080 408E	2
57322B1	STUD NUT M22X1.50 WR30	20
574221	LIMES WASHER FOR M22	20
56112518	CAP 125 BOLT ON ADR	2
57558B1	CROWN NUT M58X1.50 WR80 H38	2
58212	SPRING PIN FOR NUT M58	2
57B5801	LOCK WASHER FOR M58	2
7611503	LEVER 35 BNA FIXED	2
96308A0101	SCREW SH M08X1,25 L010	12
813104	ASSEMBLY CYLIND D030/025 S110	2
462121002	PLATE TK12 S235JR EN10025	2
96114D0901	SCREW EH M14X2,00 L090 CS08,8	2
97414D1	SELF LOCKING NUT M14X2.00 CA8	2
96120E1201	SCREW EH M20X2,50 L120 CA08,8	2

Jack Assembly

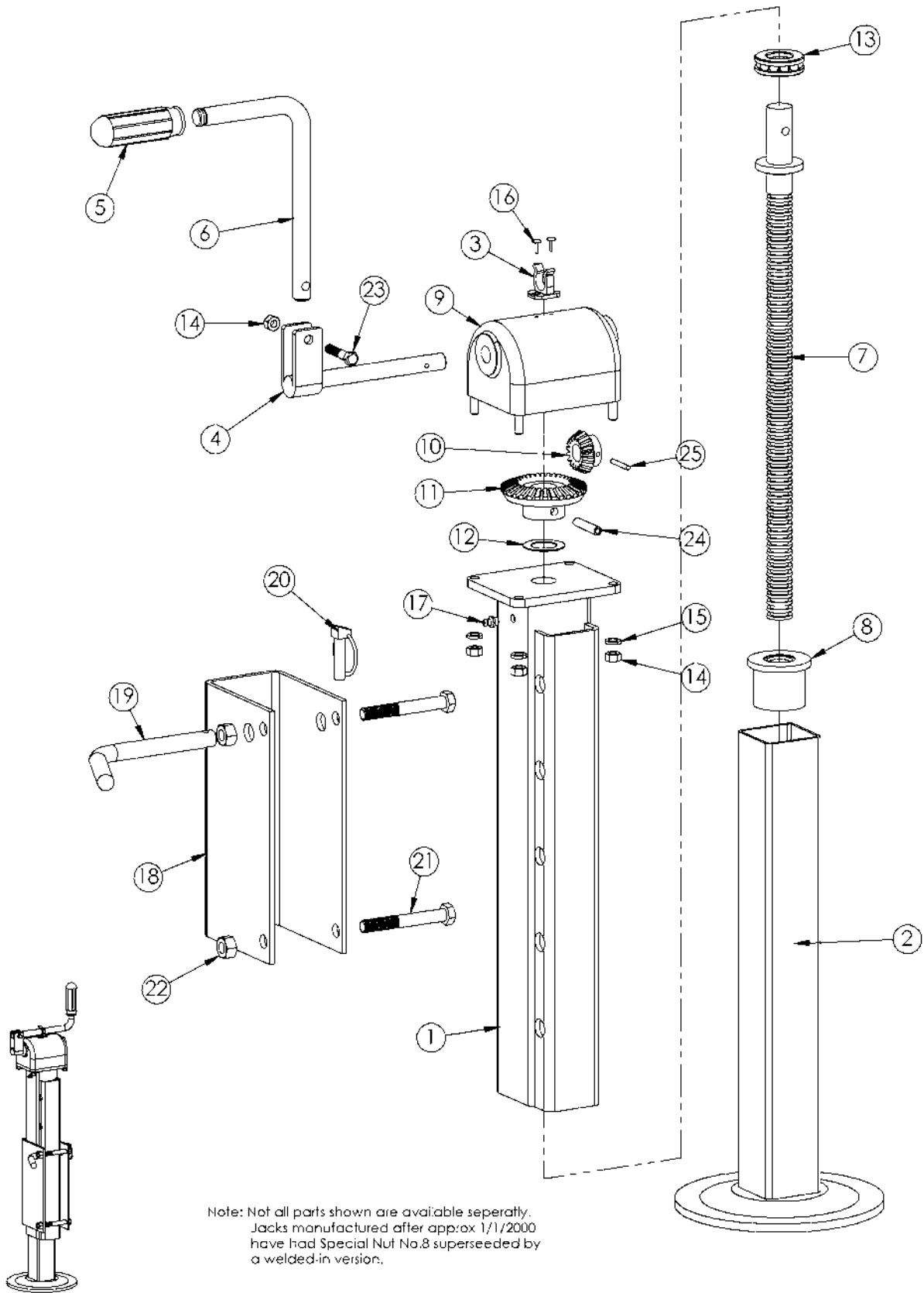

Jack Assembly Parts list

Item	Part Number	Description	Qty
-	301-4000-1	Jack Model 4 - c/w Pin, Sleeve etc.	1
-	301-4000	Jack Model 4 - no Pin, Sleeve etc.	1
1	301-4010	Upper Body	1
2	301-4017	Lower Foot	1
3	CLNPC3/4	Nylon Pole Clip $\frac{3}{4}$ "	1
4	301-4031	Shaft	1
5	301-4049	Handle Knob, Plastic	1
6	301-4056	Handle - c/w knob	1
7	301-4024	Main Thread	1
8	-	Special Nut	1
9	301-4038	Aluminium Cover	1
10	301-4058	Gear, Small	1
11	301-4059	Gear, Large	1
12	301-4044	Thrust Washer - 25x40x1	1
13	BRGT51205	Thrust Bearing, T51205	1
14	NN8	Nut , Nyloc M8	5
15	WASG8	Washer, Spring M8	4
16	RIVIT-73406	Rivit	2
17	GRN8-ST	Grease Nipple, M8x1.0 Straight	1
18	301-4100	Jack Sleeve	1
19	301-4200	Jack Pin	1
20	FP10.006	Linch Pin	1
21	B12X100	Bolt, M12x100	2
22	NN12	Nut, Nyloc M12	2
23	B8x40	Bolt, M8x40	1
24	RP8x40	Roll Pin, 8x40	1
25	RP4x30	Roll Pin, 4x30	1

Note: Not all parts are available separately.

Hydraulic Hose Assembly

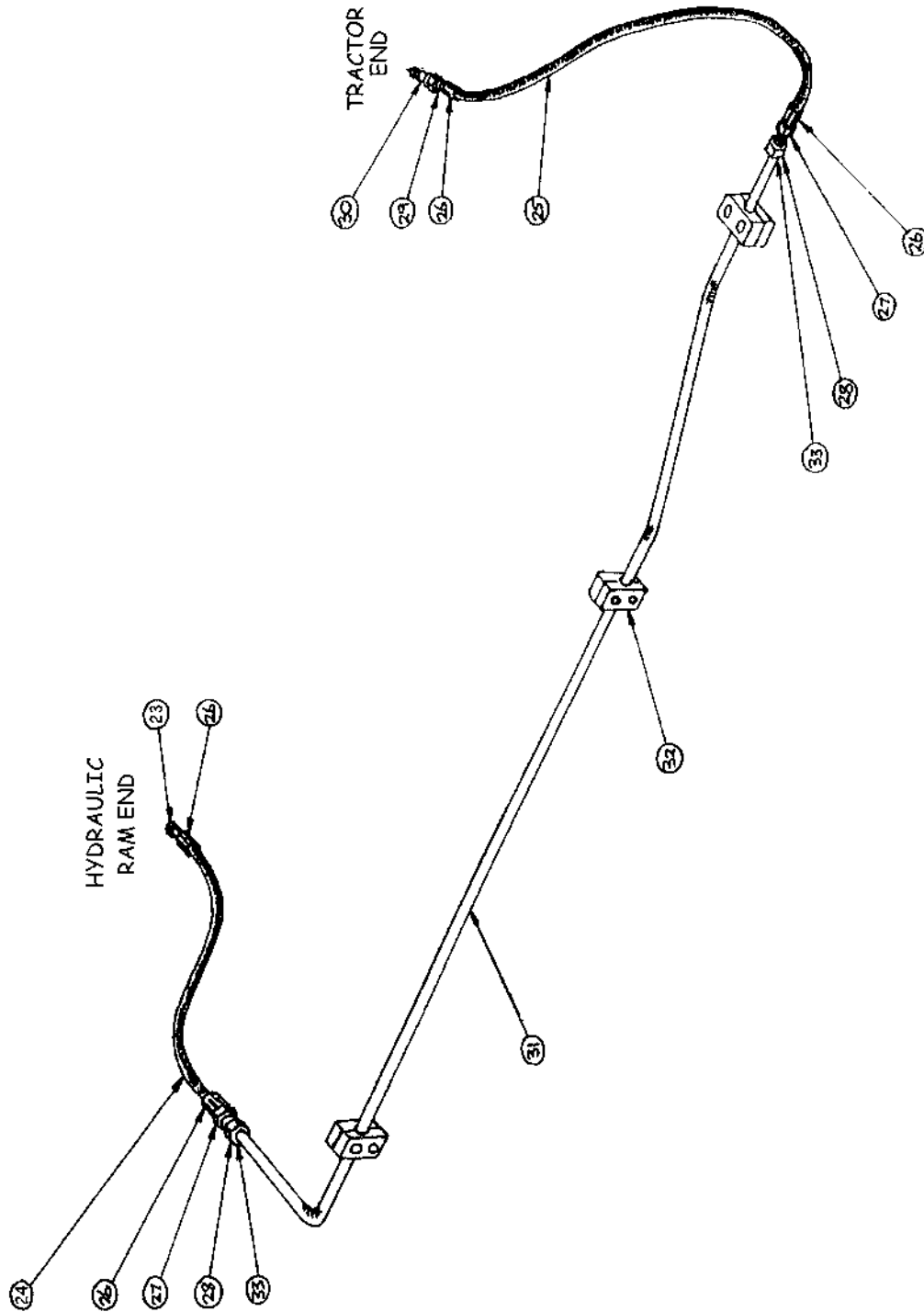

Item	Part Number	Description	Quantity Used Imperial	Quantity Used Metric
23	HYFS15-0808	Hydraulic Hose Tail, 1/2" BSP Male	1	1
23	HYFS01-0808	Hydraulic Hose Tail, 1/2" BSP Female	1	1
24	HYHGSSRAMR	Rear Hydraulic Hose, 3/8"	1	1
25	HYHGSSRAMF	Front Hydraulic Hose, 3/8"	1	1
26	HYFSN1-06	Ferrule	4	4
27	HFYS18-1206	Hydraulic Hose Tail, 3/4" JIC	1	-
27	HYFS78-M2006	Hydraulic Hose Tail, 20mm	-	1
28	HYFFC2875-10	Versil Nut, 10mm	1	-
28	HYFFTNS-12	Nut, 20mm - to suit cutting ring	-	1
29	HYFS15-0808	Hydraulic Hose Tail, 1/2" BSP Male	1	1
30	HYFQRC1/2M	Quick Release Fitting, Male 1/2"	1	1
31	HYT3/8	Steel Hydraulic Tube 3/8"ID x 5/8" OD	1	-
31	HYT16	Steel Hydraulic Tube 16mm OD x 2.0mm	-	1
32	CLCS3-M16	Tube Clamp	3	-
32		Tube Clamp	-	3
33	HYFFF9605-10	Versil Sleeve, 3/8"	2	-
33	HYFFTCS-12	Cutting Ring, 12mm	-	2

Note: Hydraulic steel tube was changed from imperial to metric during Sept 2001.

Hydraulic Suspension Parts

Version: 2/03/2020

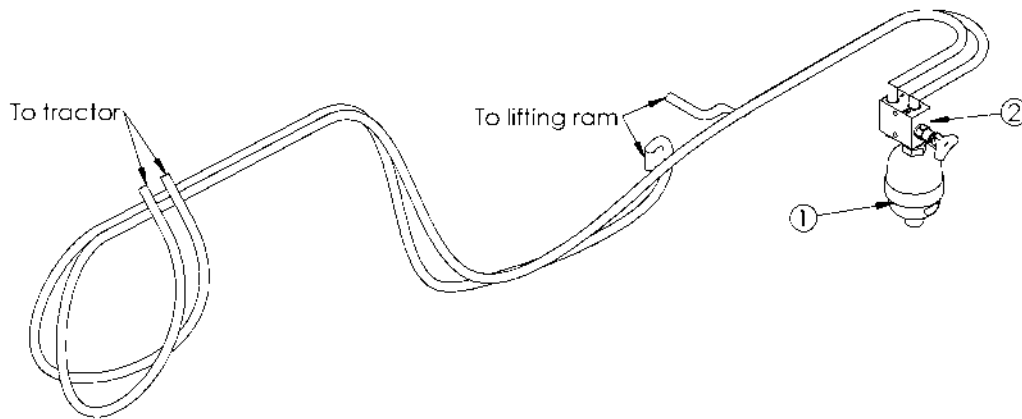

Item	Description	Part Number	Quantity
1	Hydraulic Accumulator	HYACC0.3	1
2	Shut of valve	HYHCV154H	1

Optional Autofill Assembly 6" and 8"

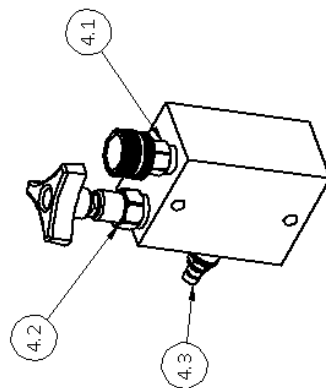
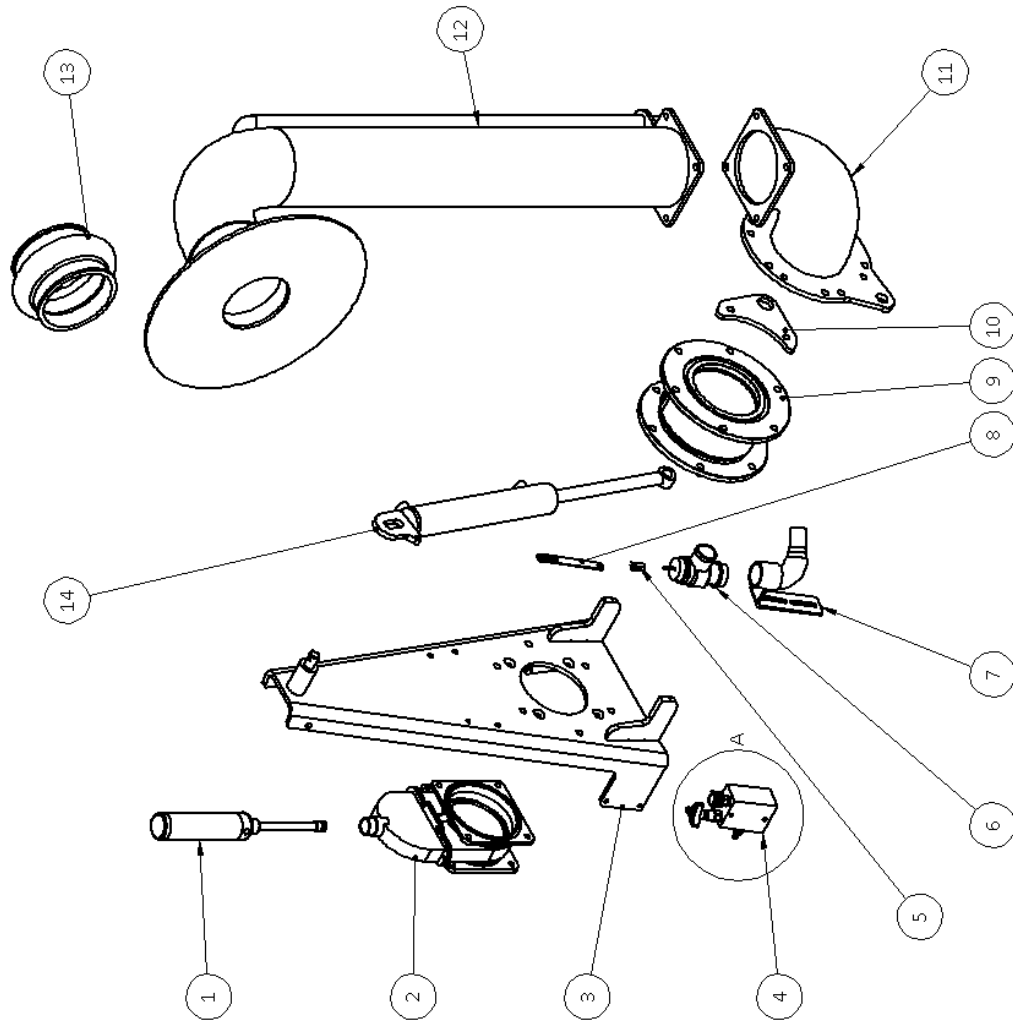

DETAIL A
SCALE 1 : 3

Optional Autofill Assembly 6” and 8”

Item No	Part No.	Description	Qty 6”	Qty 8”
1	VP-ART51	Valve ram	1	
	VP-ART50/H	Valve ram		1
2	VP-304/G	Gate valve 150mm	1	
	VP-304/H	Gate valve 200mm		1
3	598-1112	Tank mount plate	1	
	598-1114	Tank mount plate		1
4	HYHCV-2706D	Valve block	1	1
4.1	NFBC-LCN	Needle valve	1	1
4.2	NFBC-LCN	Needle valve	1	1
4.3	PRDB-LDN	Pressure reducer	1	1
5	598-1125	Valve link clevis	1	1
6	VP-306/A	Relief valve 1.5inch	1	1
7	598-1130	Valve bracket	1	1
8	598-1120	Valve link	1	1
9	VP-BP2001/G	Pivot bearing	1	
	VP-BP2001/H	Pivot bearing		1
10	598-1140	Support plate	1	
	598-1148 Support plate	Support plate		1
11	VP-AF0069/G	Base pipe	1	
	VP-AF0069/H	Base pipe		1
12	VP-AF0070/G	Centre pipe	1	
	VP-AF0070/H	Centre pipe		1
13	VP-BP1101/G	Rubber joint	1	
	VP-BP1101/H	Rubber joint		1
14	598-AFRAM	Autofill ram	1	
	RAM2X1X390AF	Autofill ram		1

Drawbar Assembly

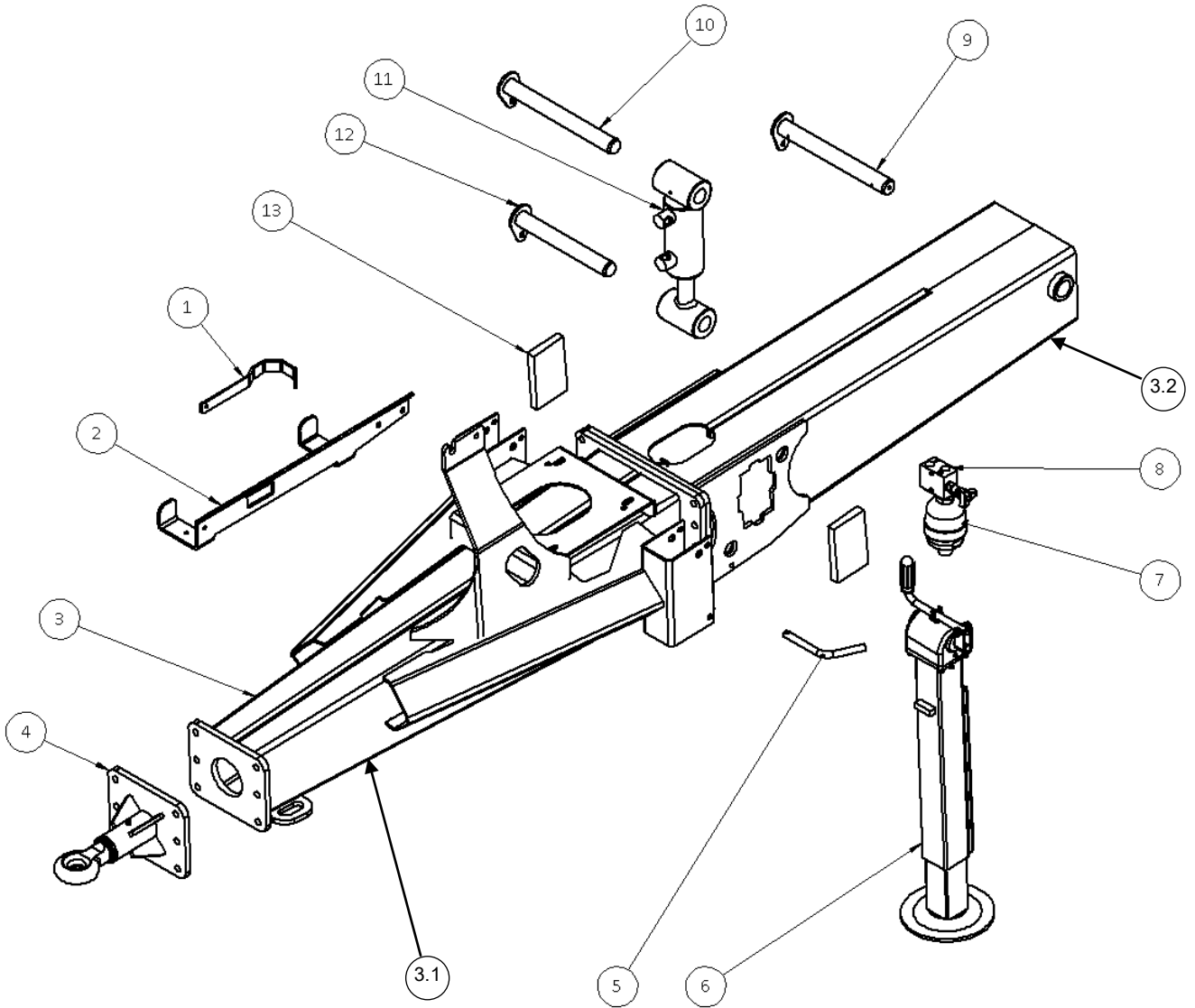

Drawbar Assembly

Item	Part no.	Description	Qty
1	598-1345	Driveshaft holder	1
2	598-1012	Hose holder	1
3		Bare drawbar	1
3.1	GSSDB-FRONT	Drawbar Front (Standard Drawbar Only)	1
3.2	GSSDB-REAR	Drawbar Rear (Standard Drawbar Only)	1
4		Tow eye assembly	
	Toweye sm assy	Fits 5000L, 7500L	1
	Toweye lg assy	Fits 10000L, 12000L, 15000L, 20000L	1
5	301-4200	Jack pin	1
6	301-4020	Jack assembly	1
7	SAIP 0.35L	Accumulator	1
8	HCV 154H P8P NFCD	Accumulator valve	1
9	598-1330	Drawbar pivot pin	1
	10785	Drawbar pivot pin for chassis boss	
10	598-1320	Drawbar top ram pin	1
11	RAM3X1.5X100	Drawbar ram	1
12	598-1325	Drawbar lower ram pin	1
13		Plastic insert	2

FITTING



FILLER WITH MECHANICAL SEAL

Rel. 0 del 10.02.2019

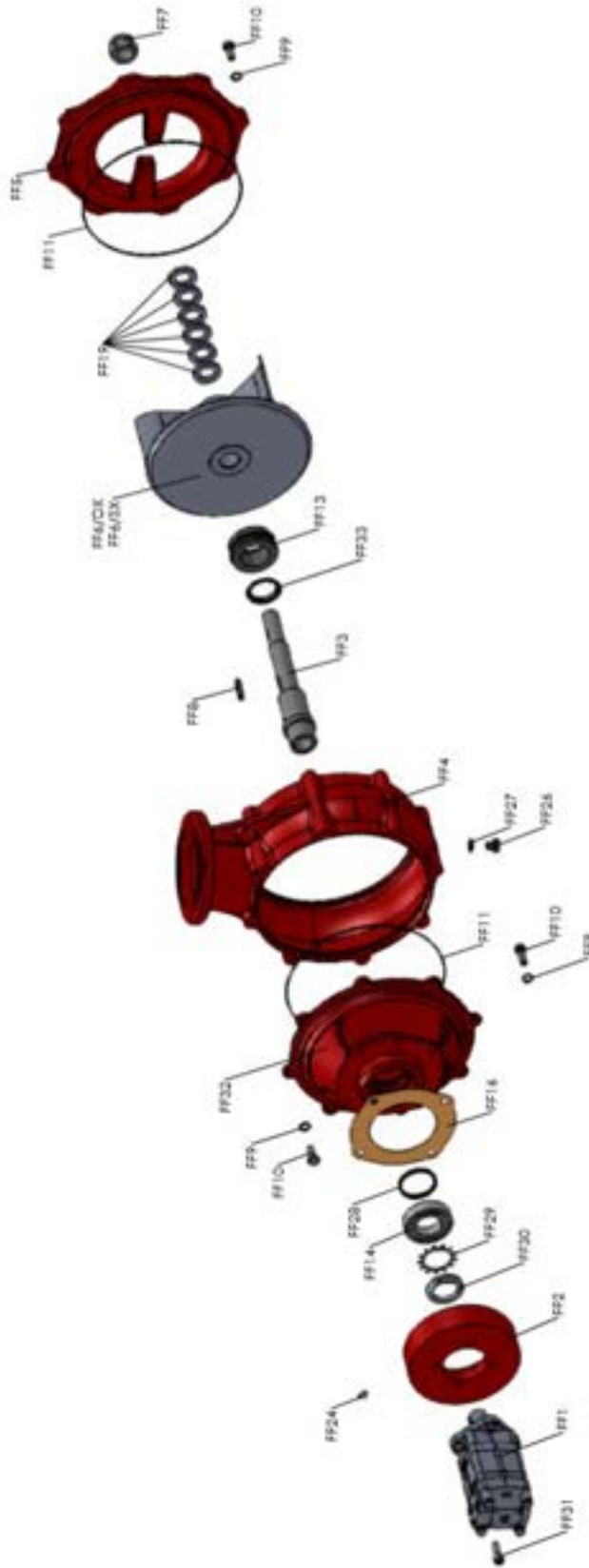

pag. 415

FITTING

catalogo ricambi
spare parts catalogue
Rev. 0 del 10.02.2019



FILLER

Articolo (Article)	Codice (Code)	Descrizione	Descrizione	Q.ty	Uta
FF1	5020400038	MOTORE IDRAULICO ORBITALE 100 CC. ALRD32	ORBITAL HYDRAULIC MOTOR 100 CC. D32 SHAFT	1	pcs
FF2	4010406023	FLANGIA DI SUPP. MOT. IDR. FILLER	HYDR. MOTOR SUPP. FLANGE - FILLER	1	pcs
FF3	4020907075	ALBERO CENTRIFUGA FILLER 6500 TM OMS100	FILLER TM SHAFT OMS 100	1	pcs
FF4	4011101004	CHIOCCIOLA GARDA 6500 - D 140	SCROLL - GARDA 6500 - D 140	1	pcs
FF5	4010401027	FLANGIA PORTALAMA GARDA CON TRINCIATORE	BLADE-HOLDER FLANGE - GARDA CUTT. DEV.	1	pcs
FF6/DX	4011219009	GIRANTE PER FILLER-EVO A TRE PALE DX	3 BLADES IMPELLER FOR FILLER-EVO	1	pcs
FF6/SX	4011219010	GIRANTE PER FILLER-EVO A TRE PALE SX	3 BLADES IMPELLER FOR FILLER CCW	1	pcs
FF7	5050300003	DADO AUTOBLOCCANTE M 30X2X25	SELF-LOCKING NUT - M 30X2X25	1	pcs
FF8	5050707009	CHIAVETTA 10X8X50	KEY - 10X8X50	1	pcs
FF9	5050207005	RONDELLA D 12	SMOOTH WASHER - D 12	20	pcs
FF10	5050107027	VITE M 12X30 TE	SCREW - M 12X30 TE	20	pcs
FF11	5030210001	ANELLO TENUTA D 291,69X3,53 GARDA 6500	SEAL RING - D 298X3,53 GARDA 6500	2	pcs
FF13	5030000003	TENUTA MECCANICA CENTRIFUGA GARDA 6500	MECHANICAL SEAL - GARDA 6500	1	pcs
FF14	5012107014	CUSCINETTO A SFERE 4210 A	BALL BEARING - 4210 A	1	pcs
FF16	4030108010	GUARN. SUPP. CHIOCCIOLA GARDA	SCROLL SUPPORT GASKET - GARDA	1	pcs
FF19	4011707083	DISTANZIALE 52X30X8	SPACER FOR CUTTING DEVICE	6	pcs
FF21	4010006005	LAMA PER TRINCIATORE	BLADE FOR CUTTING DEVICE	1	pcs
FF22	4010006006	CONTROLAMA PER TRINCIATORE	COUNTE-BLADE FOR CUTTING DEVICE	2	pcs
FF23	5050707004	CHIAVETTA 8X7X25	KEY - 8X7X25	1	pcs
FF24	5050812001	INGRASSATORE M 10X1	LUBRICATOR - M 10X1	1	pcs

**Battioni®
Pagani**



Catalogo ricambi
spare parts catalogue
Rev. 0 del 10.02.2019

FILLER

Articolo (Article)	Codice (Code)	Descrizione	Descrizione	Qty	Unit
FF25	5050107212	VITE M 10x16 TCEI	SCREW - M 10x16 TCEI	4	pcs
FF26	5050906001	TAPPO D 1/4" GAS	PLUG - D 1/4" GAS	1	pcs
FF27	5050202003	RONDELLA D 1/4" GAS ALLUMINIO	ALUMINIUM WASHER - D 1/4" GAS	1	pcs
FF28	5030300046	PARAOILIO 60X70X7	OIL SEAL 60X70X7	1	pcs
FF29	5050207042	RONDELLA MB D50 PER GHIERA	WASHER MB D50	1	pcs
FF30	5050300017	GHIERA DI BLOCCAGGIO M50X1,5	LOCKING RING M50X1,5	1	pcs
FF31	5050107148	VITE M12X35 TCEI	SCREW M12X35 TCEI	4	pcs
FF32	4011001129	SUPPORTO CHIOCCIOLA FILLER	SCROLL SUPPORT - FILLER	1	pcs
FF33	5030210015	ANELLO IN GOMMA HL187	RUBBER RING HL187	1	pcs



catalogo ricambi
 spare parts catalogue
 Rev. 0 del 10.02.2019

SWIVEL JOINT

Articolo (Article)	Codice (Code)	Descrizione	Descrizione (Description)	Qty	Uta
GG1/100	4010001007	MANICOTTO ESTERNO GIUNTO GIR. D 100	EXTERNAL COUPLING - D 100	1	pcs
GG1/150	4010001009	MANICOTTO ESTERNO GIUNTO GIR. D 150	EXTERNAL COUPLING - D 150	1	pcs
GG1/200	4010001011	MANICOTTO ESTERNO GIUNTO GIR. D 200	EXTERNAL COUPLING - D 200	1	pcs
GG1/250	4010001013	MANICOTTO ESTERNO GIUNTO GIR. D 250	EXTERNAL COUPLING - D 250	1	pcs
GG1/300	4010001062	MANICOTTO ESTERNO GIUNTO GIR. D 300	EXTERNAL COUPLING - D 300	1	pcs
GG2/100	4010001006	MANICOTTO INTERNO GIUNTO GIR. D 100	INTERNAL COUPLING - D 100	1	pcs
GG2/150	4010001008	MANICOTTO INTERNO GIUNTO GIR. D 150	INTERNAL COUPLING - D 150	1	pcs
GG2/200	4010001010	MANICOTTO INTERNO GIUNTO GIR. D 200	INTERNAL COUPLING - D 200	1	pcs
GG2/250	4010001012	MANICOTTO INTERNO GIUNTO GIR. D 250	INTERNAL COUPLING - D 250	1	pcs
GG2/300	4010001063	MANICOTTO INTERNO GIUNTO GIR. D 300	INTERNAL COUPLING - D 300	1	pcs
GG3/100	5010007003	SFERA IN ACCIAIO D 1/2" GAS	STEEL BALL - D 1/2" GAS	66	pcs
GG3/150	5010007003	SFERA IN ACCIAIO D 1/2" GAS	STEEL BALL - D 1/2" GAS	88	pcs
GG3/200	5010007003	SFERA IN ACCIAIO D 1/2" GAS	STEEL BALL - D 1/2" GAS	116	pcs
GG3/250	5010007003	SFERA IN ACCIAIO D 1/2" GAS	STEEL BALL - D 1/2" GAS	138	pcs
GG3/300	5010007003	SFERA IN ACCIAIO D 1/2" GAS	STEEL BALL - D 1/2" GAS	162	pcs
GG4	5050812001	INGRASSATORE M 10X1	LUBRICATOR - M 10X1	4	pcs
GG5	5050906006	TAPPO D 16X1.5 - DIN 908 -	PLUG - D 16X1	2	pcs
GG6	5050202007	RONDELLA D 16X20X1,5 ALLUMINIO	ALUMINIUM WASHER - D 16X20X1,5	2	pcs
GG7/100	5030210020	ANELLO TENUTA OR 200 GIUNTO D 100	SEAL RING - OR 200 GIUNTO D 100	2	pcs
GG7/150	5030210022	ANELLO TENUTA OR 228 GIUNTO D 150	SEAL RING - OR 228 GIUNTO D 150	2	pcs

pag. 424

FITTING

Catalogo ricambi
spare parts catalogue
Rev. 0 del 10.02.2019



SWIVEL JOINT

Articolo (Article)	Codice (Code)	Descrizione	Descrizione	Q.ty	Uta
GG7/200	5030210024	ANELLO TENUTA OR 243 GIUNTO D 200	SEAL RING - OR 243 GIUNTO D 200	2	pcs
GG7/250	5030210026	ANELLO TENUTA OR 250 GIUNTO D 250	SEAL RING - OR 250 GIUNTO D 250	2	pcs
GG7/300	5030210045	ANELLO TENUTA OR 81200 GIUNTO D 300	SEAL RING - OR 81200 GIUNTO D 300	3	pcs
GG8/100	5030210021	ANELLO TENUTA OR 212 GIUNTO D 100	SEAL RING - OR 212 GIUNTO D 100	2	pcs
GG8/150	5030210023	ANELLO TENUTA OR 233 GIUNTO D 150	SEAL RING - OR 233 GIUNTO D 150	2	pcs
GG8/200	5030210025	ANELLO TENUTA OR 245 GIUNTO D 200	SEAL RING - OR 245 GIUNTO D 200	2	pcs
GG8/250	5030210027	ANELLO TENUTA OR 252 GIUNTO D 250	SEAL RING - OR 252 GIUNTO D 250	2	pcs
GG8/300	5030210074	ANELLO TENUTA OR 81300 GIUNTO D 300	SEAL RING - OR 81300 GIUNTO D 300	2	pcs
GG9/100	5030210013	ANELLO TENUTA OR 193 GETTO 3°	SEAL RING - OR 193 GETTO 3°	1	pcs
GG9/150	5030210056	ANELLO TENUTA OR 6635 GIUNTO D 150	SEAL RING - OR 6635 JOINT D 150	1	pcs
GG9/200	5030210055	ANELLO TENUTA OR 6850 GIUNTO D 200	SEAL RING - OR 6850 JOINT D 200	1	pcs
GG9/250	5030210057	ANELLO TENUTA 259.7X6.99 GIUNTO D 250	SEAL RING - OR 249 JOINT D 250	1	pcs



3" - 4" MANUAL SWIVEL CAST IRON PIPE WITH FLANGE

Rel. 1 del 28.06.2019



FITTING

3" - 4" HYDRAULIC SWIVEL CAST IRON PIPE WITH FLANGE

Rel. 1 del 28.06.2019

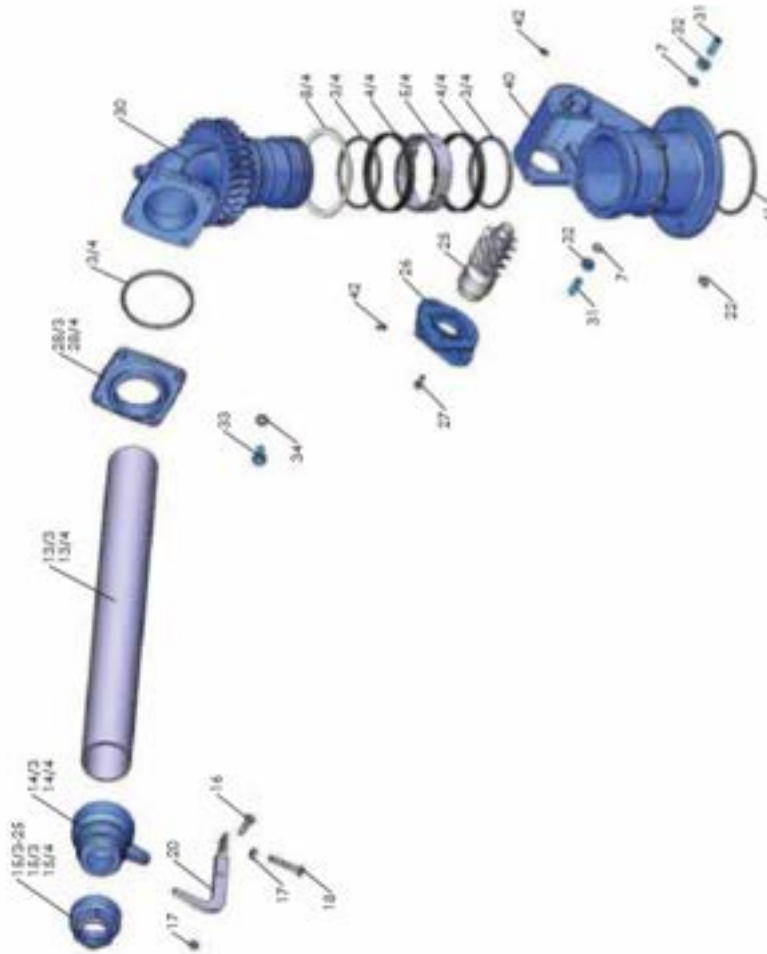



3" - 4" HYDRAULIC SWIVEL CAST IRON PIPE WITH FLANGE ADJUSTABLE

Rel. 1 del 28.06.2019

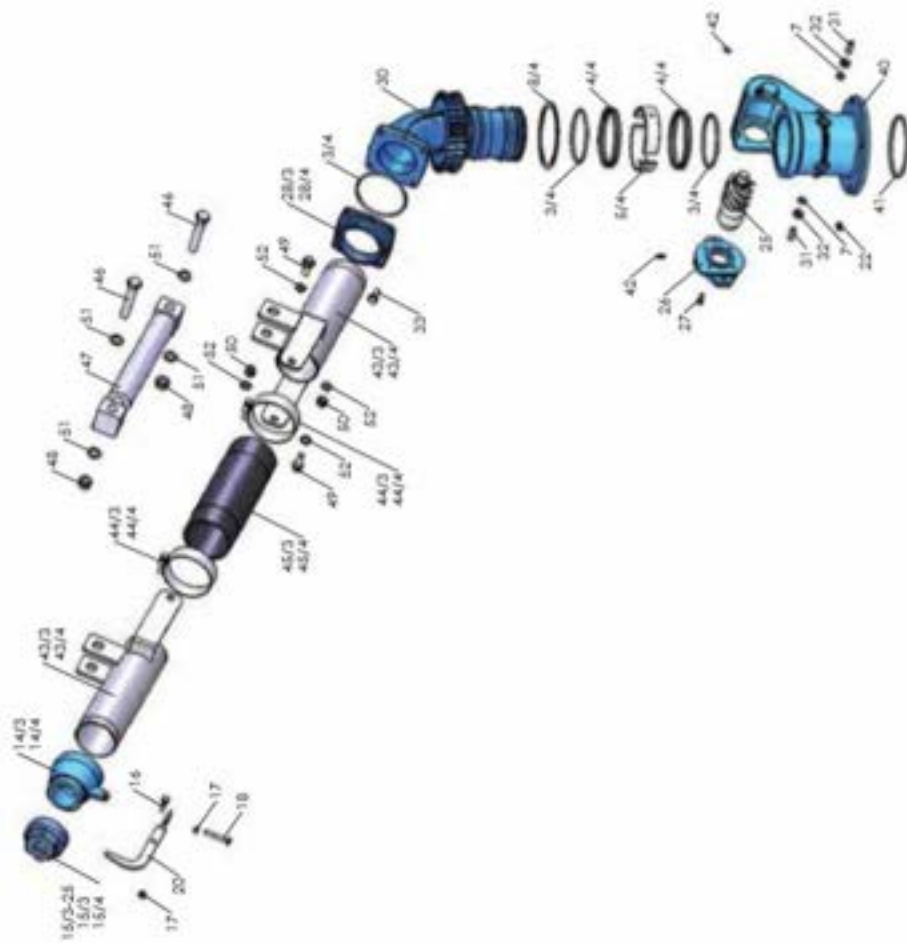



catalogo ricambi
spare parts catalogue
Rev. 0 del 10.02.2019

SWIVEL GUN

Articolo (Article)	Codice (Code)	Descrizione	Descrizione	Qty	Uta
3/4	5030210008	ANELLO TENUTA OR 189	SEAL RING - OR 189	3	pcs
4/4	5060205002	ANELLO GUIDA EDWR/AGE 110	DRIVING RING - EDWR/AGE 110	2	pcs
5/4	4011806002	ANELLO FISSAGGIO GETTO 3-4"	FASTENER RING - PIPE 3-4"	2	pcs
7	5050202002	RONDELLA Ø 10X16X1,5 ALLUMINIO	ALUMINIUM WASHER - Ø 10X16X1,5	2	pcs
8/4	5060205004	ANELLO STRISCIAMENTO GETTO	SLIDING RING - GETTO"	1	pcs
9	4011704001	BOCCOLA Ø 32X22X25 GETTO GIREVOLE	BUSH - Ø 32X22X25 SWIVEL PIPE	1	pcs
13/3	4011806003	TUBO TRAFILATO Ø 2" 1/2X750 GETTO 3"	DRAWN HOSE - Ø 2" 1/2X750 PIPE 3"	1	pcs
13/4	4011806004	TUBO TRAFILATO Ø 3"X750 GETTO 4"	DRAWN HOSE - Ø 3"X750 PIPE 4"	1	pcs
13/5	4011806030	TUBO TRAFILATO Ø 3" 1/2X740 GETTO 5"	DRAWN HOSE - Ø 3" 1/2X740 PIPE 5"	1	pcs
14/3	4010001001	PORTAUGELLO GETTO 3"	NOZZLE HOLDER - SWIVEL GUN 3"	1	pcs
14/4	4010001003	PORTAUGELLO GETTO 4"	NOZZLE HOLDER - SWIVEL GUN 4"	1	pcs
14/5	4010001060	PORTAUGELLO GETTO 5"	NOZZLE HOLDER - SWIVEL GUN 5"	1	pcs
15/3	4010001002	UGELLO GETTO 3"	NOZZLE - SWIVEL GUN 3"	1	pcs
15/3-25	4010001005	UGELLO GETTO 3" - FORO Ø 25 mm	NOZZLE - SWIVEL GUN 3" - HOLE Ø 25 mm	1	pcs
15/4	4010001004	UGELLO GETTO 4"	NOZZLE - SWIVEL GUN 4"	1	pcs
15/5	4010001058	UGELLO GETTO 5" - Ø45	NOZZLE - SWIVEL GUN 5" - Ø45	1	pcs
16	5050107048	VITE M 8X30 TE ZINCATO	GALVANIZED SCREW - M 8X30 TE	1	pcs

FITTING



catalogo ricambi
spare parts catalogue
Rev. 0 del 10.02.2019

SWIVEL GUN

Articolo (Part)	Codice Code	Descrizione	Descrizione	Qty	Uta
17	5050307007	DADO M 8 ZINCATO	NUT - M 8 GALVANIZED	2	pcs
18	5050107013	VITE M 8X50 TE ZINCATA - TUTTO FILETTO -	GALVANIZED SCREW - M 8X50 TE	1	pcs
20	4010006004	FRANGIGETTO GETTO GIREVOLE	BREAK-SEWAGE - SWIVEL GUN	1	pcs
22	5050812003	INGRASSATORE M 10X1.5	LUBRICATOR - M 10X1.5	2	pcs
25	4020006003	VITE SENZA FINE GETTO IDRAULICO	WORM - PIPE HYDRAULIC	1	pcs
26	4010406006	FLANGIA COLLEG. MOT. IDR. GETTO GIREVOLE	HYDR. MOTOR CONN. FLANGE - SWIVEL PIPE	1	pcs
27	5050107008	VITE M 6X16 TCEI	SCREW - M 6X16 TCEI	4	pcs
28/3	4010601080	COPERCHIO PORTATUBO GETTO 3"	HOSE-HOLDER COVER - GETTO 3"	1	pcs
28/4	4010601079	COPERCHIO PORTATUBO GETTO 4"	HOSE-HOLDER COVER - GETTO 4"	1	pcs
29	4011001015	SUPPORTO GETTO 3-4" MANUALE	SUPPORT - MANUAL SWIVEL PIPE 3-4"	1	pcs
30	4010101033	CORPO GIREVOLE - GETTO	REVOLVING BODY - PIPE	1	pcs
31	5051007003	GRANO M 10X30 PCIL.	DOWEL - M 10X30 PP.	2	pcs
32	5050307003	DADO M 10	NUT - M 10	2	pcs
33	5050107020	VITE M 10X25 TE	SCREW - M 10X25 TE	4	pcs
34	5050207004	RONDELLA Ø 10	SMOOTH WASHER - Ø 10	4	pcs
35	4020006002	VITE SENZA FINE GETTO MANUALE	WORM - PIPE MANUAL	1	pcs
36	4010406005	FLANGIA CHIUSURA GETTO GIREVOLE	GRIPPING FLANGE - SWIVEL PIPE	1	pcs

Battioni®
Pagani



catalogo ricambi
spare parts catalogue
Rev. 0 del 10.02.2019

SWIVEL GUN

Articolo (Article)	Codice (Code)	Descrizione	Descrizione	Qty	Uta
37	5050107006	VITE M 6X20 TE	SCREW - M 6X20 TE	4	pcs
38	5050207002	RONDELLA Ø 6	SMOOTH WASHER - Ø 6	4	pcs
39	5050207013	RONDELLA Ø 30X22X2 OTTONE	BRASS KASHER - Ø 30X22X2	1	pcs
40	4011001020	SUPPORTO GETTO 3-4" IDRAULICO	SUPPORT - HYDRAULIC SWIVEL PIPE 3-4"	1	pcs
41	5030210014	ANELLO TENUTA OR 199 GETTO 4"	SEAL RING - OR 199 GETTO 4"	1	pcs
42	5050812004	INGRASSATORE M 6X1	LUBRICATOR - M 6X1	2	pcs
43/3	4011806025	TUBO GETTO GIREVOLE REG.ALTEZZA 3"	PIPE FOR ADJUSTABLE GUN 3"	2	pcs
43/4	4011806026	TUBO GETTO GIREVOLE REG.ALTEZZA 4"	PIPE FOR ADJUSTABLE GUN 4"	2	pcs
44/3	5100706003	FASCETTA STRINGITUBO Ø 80	CLAMP - Ø 80	2	pcs
44/4	5100706010	FASCETTA STRINGITUBO Ø 110	CLAMP - Ø 110	2	pcs
45/3	4011707080	TUBO GOMMA FLESSIBILE GETTO REG.H 3"	FLEXIBLE HOSE ADJ. GUN 3"	1	pcs
45/4	4011707081	TUBO GOMMA FLESSIBILE GETTO REG.H 4"	FLEXIBLE HOSE ADJ. GUN 4"	1	pcs
46	5050107128	VITE ZINCATA M 18X100 TE	SCREW - M 18X100 TE GALVANIZED	2	pcs
47	5090000080	CILINDRO IDR. DA GETTO REG. ALT. (H S.)	HYDRAULIC CYLINDER - SWIVEL GUN	1	pcs
48	5050300015	DADO AUTOBLOCCANTE M 18	SELF-LOCKING NUT M 18	2	pcs
49	5050107127	VITE ZINCATA M 12X30 TE	SCREW - M 12X30 TE GALVANIZED	2	pcs
50	5050300013	DADO AUTOBLOCCANTE M 12 BASSO - DIN 985	SELF-LOCKING NUT M 12	2	pcs

FITTING

Catalogo ricambi
spare parts catalogue
Rev. 0 del 10.02.2019



SWIVEL GUN

Articolo (Article)	Codice (Code)	Descrizione	Descrizione	Qty	Uta
51	5050207026	RONDELLA Ø 18 ZINCATA	GALVANIZED FLAT WASHER - Ø 18	4	pcs
52	5050207025	RONDELLA Ø 12 ZINCATA	GALVANIZED FLAT WASHER - Ø 12	4	pcs
53	5050107109	VITE M 10X25 TEF	SCREW - M 10X25 TEF	4	pcs
54/4	4010601202	COPERCHIO PORTATUBO GETTO HD 4"	HOSE-HOLDER COVER - GETTO 4" HD	1	pcs
54/5	4010601201	COPERCHIO PORTATUBO GETTO HD 5"	HOSE-HOLDER COVER - GETTO 5" HD	1	pcs
55	5030210098	ANELLO TENUTA 107,2X5,34 OR 6425	SEAL RING - 107,2X5,34 OR 6425	1	pcs
56	4010101186	CORPO GIREVOLE - GETTO 4"-5" HD	REVOLVING BODY - PIPE 4"-5" HD	1	pcs
57	5030210002	ANELLO TENUTA OR 4625	SEAL RING - OR 4625	1	pcs
58	5010007003	SFERA IN ACCIAIO Ø1/2"	STEEL BALL Ø 1/2"	52	pcs
59	5020400011	MOTORE IDRAULICO ORBITALE 315 CC	ORBITAL HYDRAULIC MOTOR 315 CC	1	pcs
60	4011001153	SUPPORO GETTO HD IDRAULICO 4"-5"	SUPPORT - HYDRAULIC SWIVEL PIPE 4"-5" HD	1	pcs
61	5050202007	RONDELLA Ø 16X20X1,5 ALLUMINIO	FLAT WASHER - Ø 16X20X1,5	2	pcs
62	5050906006	TAPPO Ø 16x1,5 - DIN 908	PLUG Ø 16X1,5 - DIN 908	2	pcs